

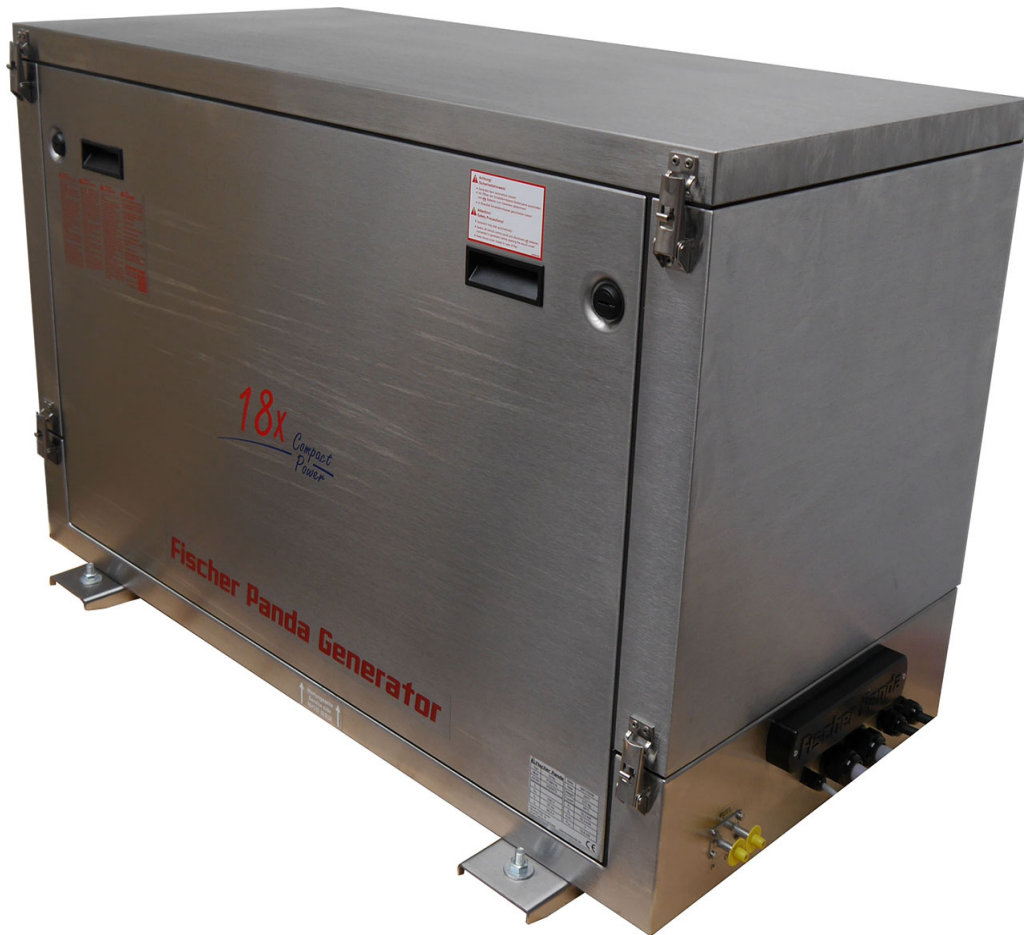

# Fischer Panda



## Vehicles Generator Manual

Panda 18x PVMV-N - Panda 30x PVMV-N

230 V - 50 Hz

400 V - 50 Hz

Super silent technology



## Current revision status

	Document
Actual:	Panda_18x-30x_PVMV-N_eng.R01.1.10.3.26
Replace:	

Revision	Page
	1
	83

### Erstellt durch / created by

Fischer Panda GmbH - Leiter Technische Dokumentation

Otto-Hahn-Str. 32-34

33104 Paderborn - Germany

Tel.: +49 (0) 5254-9202-0

email: [info@fischerpanda.de](mailto:info@fischerpanda.de)

web: [www.fischerpanda.de](http://www.fischerpanda.de)

### Copyright

**Duplication and change of the manual is permitted only in consultation with the manufacturer!**

Fischer Panda GmbH, 33104 Paderborn, reserves all rights regarding text and graphics. Details are given to the best of our knowledge. No liability is accepted for correctness. Technical modifications for improving the product without previous notice may be undertaken without notice. Before installation, it must be ensured that the pictures, diagrams and related material are applicable to the genset supplied. Enquiries must be made in case of doubt.



# Inhalt / Contens

<b>Current revision status</b> .....	<b>2</b>
<b>1 General information and regulations</b> .....	<b>12</b>
1.1 Safety First.....	12
1.2 Environmental protection .....	13
1.3 Customer registration and guarantee .....	14
1.3.1 Technical support .....	14
1.3.2 Caution, important information for start-up! .....	14
1.4 Safety Instructions - Safety First! .....	15
1.4.1 Safe operation .....	15
1.4.2 Observe safety instructions! .....	15
1.4.3 Personal protective clothing (PPE) .....	15
1.4.4 Cleanliness ensures safety .....	15
1.4.5 Safe handling of fuels and lubricants .....	16
1.4.6 Exhaust fumes and fire protection .....	16
1.4.7 Safety precautions against burns and battery explosions .....	17
1.4.8 Protect your hands and body from rotating parts! .....	17
1.4.9 Anti-freeze and disposal of fluids .....	17
1.4.10 Implementation of safety inspections and maintenance .....	18
1.5 Warning and instruction signs.....	18
1.5.1 Special instructions and hazards of generators .....	18
1.5.1.1 Protective conductor and potential equalisation:.....	19
1.5.1.2 Protective conductor for Panda AC generators:.....	19
1.5.1.3 Switch off all loads while working on the generator .....	19
1.5.1.4 Potential equalisation for Panda AGT DC generators.....	19
1.5.1.5 Safety instructions concerning cables.....	20
1.5.2 General safety instructions for handling batteries .....	20
<b>2 In case of Emergency First Aid</b> .....	<b>21</b>
2.1 WHEN AN ADULT STOPS BREATHING .....	22
<b>3 Basics</b> .....	<b>23</b>
3.1 Intended use of the machine .....	23
3.2 Purpose of the manual and description of the definitions of the trained persons/operators/users .	23
3.2.1 Trained persons .....	23
3.2.2 Operator/Owner .....	23
3.2.3 User .....	24
3.3 Components of the xGenerator .....	24
3.4 Range of operation .....	26
3.5 Panda transport box .....	26
3.5.1 Bolted Fischer Panda transport box .....	26
3.5.2 Fischer Panda transport box with metal tab closure .....	26
3.6 Opening the MPL sound insulation capsule .....	27
3.6.1 Opening the GFK sound insulation capsule .....	28
3.7 Transport and loading/unloading .....	29
3.7.1 Transporting the generator .....	29
3.7.2 Loading/unloading of the generator .....	29
3.8 Special service instructions and measures for extended machine downtimes and decommissioning	29
3.8.1 Instructions for the starter battery for extended downtimes .....	30
3.8.2 Measures for short downtimes .....	30



# Inhalt / Contents

3.8.3	Measures for medium term downtimes / hibernation .....	30
3.8.3.1	Courses for preservation: .....	31
3.8.3.2	Measures for removing surface protection after medium term downtimes (3 to 6 months). 31	
3.8.4	Measures for extended downtimes / decommissioning .....	32
3.8.4.1	Courses for preservation: .....	32
3.8.4.2	Measures for removing surface protection after extended downtimes / recommissioning (over 6 months): 32	
<b>4</b>	<b>The Panda Generator .....</b>	<b>35</b>
4.1	Type plate at the Generator .....	35
4.2	Description of the Generator .....	36
4.2.1	Right Side View .....	36
4.2.2	Left Side View .....	37
4.2.3	Front View .....	38
4.2.4	Back View .....	39
4.3	Details of functional units .....	40
4.3.1	xControl panel .....	40
4.3.2	.....	40
4.3.3	The cooling system .....	41
4.3.4	The fuel and combustion air system .....	42
4.3.5	Sensors and switches for operating surveillance .....	43
4.3.6	The oil circuit - Schema .....	45
<b>5</b>	<b>Installation Instructions .....</b>	<b>47</b>
5.1	Personal requirements .....	47
5.1.1	Hazard notes for the installation .....	47
5.2	Environmental protection .....	49
5.3	Placement .....	50
5.3.1	General instructions .....	50
5.3.2	Preparing the base - Placement .....	50
5.3.3	Advice for optimal sound insulation .....	51
5.4	Air suction filter as a source of noise .....	52
5.5	Generator Connections .....	52
5.6	Fuel system installation .....	52
5.6.1	The following items need to be installed: .....	52
5.6.2	Connection of the fuel lines at the tank .....	53
5.6.3	Position of the pre-filter with water separator .....	54
5.7	Ventilating the Fuel System .....	54
5.8	Installation of the cooling system .....	55
5.8.1	The cooling system / general instructions .....	55
5.9	Radiator baseplate .....	55
5.9.1	Determining the size of the radiator .....	55
5.9.2	Radiator design .....	56
5.9.3	Radiator types .....	56
5.9.3.1	Installation location for radiators for roof, side, or underfloor mounting on the vehicle 57	
5.9.3.2	Roof installation .....	57
5.9.3.3	Installation on the vehicle wall .....	59
5.9.3.4	Underfloor installation of radiator .....	60



## Inhalt / Contens

5.9.3.5	Installation location for radiator in the vehicle wall or cabin wall .....	61
5.9.3.6	Installation location for radiator in a tunnel.....	62
5.9.3.7	Installation location for generators of the PVK-UK series .....	63
5.9.4	Coolant hoses .....	63
5.9.5	Connection of the external radiator .....	63
5.9.6	Coolant expansion tank .....	64
5.9.7	Installation of a coolant temperature indicator .....	64
5.9.8	Permissible coolant temperatures .....	64
5.9.9	Coolant pump .....	64
5.9.10	Radiator fan .....	65
5.9.11	Anti-freeze and corrosion protection .....	65
5.9.12	Logging the temperature values during initial start-up .....	65
5.10	Custom installations.....	66
5.10.1	External heat exchangers .....	66
5.10.2	External engine pre-heater .....	66
5.10.3	Keel cooling .....	66
5.11	Installation schematics .....	67
5.11.1	Installation for vertical radiator installation .....	67
5.11.2	Installation for mounting the radiator under the vehicle .....	67
5.11.3	Installation schematic for roof mounted radiator with expansion tank .....	68
5.11.4	Installation radiator with intercooler - schematic sample vertical radiator .....	68
5.12	Exhaust installation.....	69
5.12.1	Exhaust connection for roof outlet .....	69
5.12.2	Exhaust connection for mounting below the vehicle .....	69
5.13	Connection of the Electrical Components.....	70
5.14	Generator AC System Installation .....	71
5.14.1	3-phase Generator .....	71
5.14.2	AC-Control box .....	71
5.14.3	Installation with looped-in AC-Control box .....	74
5.14.4	Installation AC-Box / Distribution panel connected separately .....	74
5.14.5	Electronic voltage control xControl/fpControl .....	75
5.14.6	Connection to the AC on-board power supply .....	75
5.14.6.1	Protective conductor .....	75
5.14.6.2	Electrical fuse.....	75
5.14.6.3	Required cable crosssections .....	75
5.15	Generator DC system installation .....	75
5.15.1	Connection of the starter battery block .....	76
5.15.2	Connection of the remote control panel - see separate control panel manual .....	78
5.16	Connection Box – Generator xControl – CB-G.....	78
5.16.1	xControl ECU .....	78
5.16.2	FP CAN-Bus for internal use .....	79
5.16.3	Boostrelay (optional) .....	79
5.16.4	Line Relay (optional) .....	79
5.16.5	Autostart (optional) .....	79
5.16.6	Emergency Stop (optional) .....	79
5.16.7	Fuel pump .....	79
5.16.8	Optional DC-OUT .....	79
5.16.9	FP CAN-Bus RJ45 .....	79
5.17	Radiator fan control / electronic fan control .....	79



## Inhalt / Contents

5.18	Standard fan control for 1-phase and 3-phase generators .....	80
5.19	Electronic fan control for DC fans RE 0201 .....	82
5.20	Brief description .....	82
5.20.1	Function .....	82
5.20.2	Master - Slave - Operation .....	83
5.20.3	Function of the clamps for the Master-Slave-Operation .....	84
5.20.4	Remote controlled switching on and off of the fan controller .....	84
5.20.5	12 V / 24 V - Operation .....	84
5.21	Technical Data .....	85
5.22	Electronic fan control for single phase fans PKE-2.5V_Ziehl Abegg .....	87
5.22.1	Preset for the use with Fischer Panda generators .....	87
5.22.2	Connection of the sensor (Ziehl Abegg KTY) .....	88
5.23	Electronic fan control for single phase fans PXET6Q_Ziehl Abegg .....	89
5.23.1	Preset for the use with Fischer Panda generators .....	89
5.23.2	Connection of the sensor (Ziehl Abegg KTY) .....	90
5.24	Electronic fan control for 3 phase fans PKD T5/PKD M10 Ziehl Abegg.....	91
5.24.1	Configuration of the electronic fan control PKD T5 for Fischer Panda Generators .....	92
5.25	Configuration of the electronic fan control PKD M10 for Fischer Panda Generators.....	93
5.26	Insulation test.....	94
5.27	Set into operation.....	94
<b>6</b>	<b>Generator operation instruction .....</b>	<b>95</b>
6.1	Personal requirements.....	95
6.1.1	Hazard notes for the operation .....	95
6.2	General operating instruction.....	95
6.2.1	Operation at low temperatures .....	95
6.2.1.1	Pre-heating the diesel motor .....	96
6.2.1.2	Tips regarding starter battery .....	96
6.2.2	Light load operation and engine idle .....	96
6.2.2.1	The soot of the generator is due to the fact that:.....	96
6.2.2.2	To prevent the soot of the generator following steps should be observed: .....	96
6.2.3	Generator load for a longer period and overload .....	96
6.2.4	Protection conductor: (AC Generators only) .....	97
6.2.5	Operating control system on the Fischer Panda generator .....	97
6.3	Instructions for capacitors - not present at all models.....	97
6.4	Checks before start, starting and stopping the generator .....	97
6.5	Instructions for capacitors - not present at all models.....	98
<b>7</b>	<b>Maintenance Instructions .....</b>	<b>99</b>
7.1	Personal requirements.....	99
7.1.1	Hazard notes for the maintenance .....	99
7.2	Environmental protection .....	101
7.3	Maintenance requirements .....	101
7.4	Maintenance interval.....	101
7.5	De-aerating of the coolant circuit .....	101
7.6	Replacing the air filter .....	104
7.7	Replace the air filter .....	105



## Inhalt / Contents

7.8	Checking oil-level.....	107
7.8.1	Refilling oil .....	108
7.8.2	After the oil level check and refilling the oil .....	109
7.9	Replacement of engine oil and engine oil filter .....	109
7.9.1	After the oil change .....	111
7.10	Verifying the starter battery and (if necessary) the battery bank .....	112
7.10.1	Battery .....	112
7.10.1.1	Check battery and cable connections .....	112
7.10.1.2	Check electrolyte level .....	112
7.10.1.3	Check electrolyte density .....	113
7.11	Ventilating the fuel system .....	114
7.12	Replacement of the fuel filter .....	115
7.12.1	Optional fuel filter with sight glass .....	115
7.13	Replacing the V-belt at Kubota 02/03/05 series .....	116
<b>8</b>	<b>Generator Failure .....</b>	<b>119</b>
8.1	Personal requirements.....	119
8.2	Hazard notes for the troubleshooting.....	119
8.3	Tools and measuring instruments .....	121
8.4	Overloading the Generator .....	121
8.4.1	Effects of Short Circuiting and Overloading on the Generator .....	121
8.4.2	Overloading the Generator with Electric Motors .....	121
8.4.3	Generator Voltage Fluctuations and Monitoring .....	122
8.4.4	Automatic Voltage Monitoring and Auto-Shut Down .....	122
8.5	Low Generator-Output Voltage.....	122
8.5.1	Discharge the capacitors .....	122
8.5.2	Checking the Capacitors .....	123
8.6	Testing generator stator windings .....	125
8.6.1	Checking the generator voltage .....	125
8.6.2	Measuring the coil resistance .....	125
8.6.3	Checking the coil(s) to short-circuit .....	125
8.6.4	Measuring the inductive resistance .....	126
8.6.5	Testing generator stator winding for „shorts“ to ground .....	126
8.6.6	Coil Resistance Measurements in Stator Windings .....	132
8.6.6.1	Checking windings.....	132
8.7	Measuring the Coil Inductive Resistance.....	133
8.8	Generator provides no Voltage.....	133
8.8.1	Rotor Magnetism Loss and „Re-magnetizing“ .....	133
8.8.2	Stop solenoid .....	134
8.8.3	Damage to starter motor .....	135
8.9	Troubleshooting Table .....	136
8.9.1	Generator faults .....	136
8.9.1.1	Generator output to low. For 50 Hz versions: less than 200 V. For 60 Hz versions: less than 100 V. 136	
8.9.1.2	Generator voltage to high (more then 240 V-50 Hz / 135 V-60 Hz). If the generator is providing excessively high voltage, the following potential causes should be investigated: 136	
8.9.1.3	Generator voltage fluctuates.....	136
8.9.1.4	Generator is not able to start a electric motor.....	136



# Inhalt / Contents

8.9.1.5	Diesel motor fails to start.....	136
8.9.1.6	Starter motor is turning the engine, but generator fails to start. ....	137
8.9.1.7	Motor does not achieves enough speed during starting process. ....	137
8.9.1.8	Motor runs irregular.....	137
8.9.1.9	Motor speed drops. ....	137
8.9.1.10	Motor runs in off position. ....	138
8.9.1.11	Motor stops by itself. ....	138
8.9.1.12	Sooty black exhaust. ....	138
8.9.1.13	Generator must be shut off immediately if:.....	138
<b>9</b>	<b>Appendix.....</b>	<b>139</b>
9.1	Engine oil.....	139
9.1.1	Engine oil classification.....	139
9.2	Coolant specification.....	139
9.2.1	Coolant mixture ratio.....	140
9.3	Fuel.....	140
9.4	Technical data coil.....	140
9.5	Cable cross-section.....	141
9.6	Technical data.....	142
	<b>Panda xControl Manual.....</b>	<b>145</b>
	<b>Current revision status.....</b>	<b>146</b>
<b>10</b>	<b>Panda xControl Safety Instructions.....</b>	<b>147</b>
10.1	Personnel.....	147
10.2	Safety instructions.....	147
<b>11</b>	<b>Panda xControl.....</b>	<b>149</b>
11.1	Components of the xControl.....	149
11.1.1	xControl - CP-G.....	149
11.1.2	xControl - GC-S.....	149
11.1.3	xControl - CB-G.....	149
11.2	Installation.....	150
11.2.1	Installation of the Electronic Control Unit (ECU) xControl - GC-S.....	150
11.2.2	Installation of the Connection Box xControl - CB-G.....	150
11.2.3	Installation of the xControl - CP-G.....	150
11.3	Operation.....	151
11.3.1	Switching on the generator.....	151
11.3.1.1	Overview page with Autostart activated.....	152
11.3.2	The overview pages.....	152
11.3.3	Symbols used in overview pages.....	153
11.4	Starting up the generator.....	155
11.4.1	Preparations for starting up / Checks (daily) for marine version.....	155
11.4.2	Preparations for starting up / Checks (daily) for vehicle version.....	155
11.4.3	Starting up the generator.....	156
11.4.4	Stopping the generator.....	157
11.5	The Menu.....	158
11.5.1	Main Menu.....	158
11.5.2	Sub-menu: "Panel".....	159
11.5.2.1	Setting the illumination of the CP-G.....	159
11.5.2.2	Setting the contrast of the CP-G.....	160



## Inhalt / Contents

11.5.2.3	Setting the standby time of the CP-G.....	160
11.5.2.4	Setting the standby illumination of the CP-G .....	160
11.5.2.5	Setting the display mode of the CP-G overview page.....	160
11.5.2.6	Setting the language of the text pages of the CP-G.....	161
11.5.2.7	Setting the Temperature Unit.....	161
11.5.2.8	Setting the Aural Alarm .....	161
11.5.2.9	Setting the display to flash in the event of a fault.....	162
11.5.2.10	Setting the Panel Heating .....	162
11.5.2.11	Setting the display of the optional measurement data .....	162
11.5.2.12	Resetting all values of the Panel sub-menu to default values.....	163
11.5.2.13	Return to Main Menu.....	163
11.5.3	Sub-menu: "Generator" .....	163
11.5.3.1	Setting the Autostart of the CP-G.....	164
11.5.3.2	Setting the optional DC output of the CP-G .....	165
11.5.3.3	Switching the switching outputs of the CP-G .....	165
11.5.3.4	Reading out the Event Log of the CP-G.....	166
11.5.3.5	Resetting all values of the Generator sub-menu to the default values.....	166
11.5.3.6	Returning the Main Menu.....	166
11.5.4	Resetting the panel language to the default (English) .....	166
11.5.4.1	How to set the panel language after a reset. ....	167
11.6	Faults.....	167
11.6.1	Symbols and messages on the display .....	167
11.6.1.1	Example of message - "Sensor defective" .....	167
11.6.1.2	Example of message - "Sensor/Cable break" .....	167
11.6.2	Error code .....	167
11.6.2.1	Table of Faults .....	168
11.6.2.2	Description of the symbols .....	170
11.7	Accessories: .....	171
11.7.1	Dimensional drawing .....	172



Leere Seite / Intentionally blank



---

## Dear Customer,

Thank you for purchasing a Fischer Panda Generator and choosing Fischer Panda as your partner for mobile power on board. With your generator, you now have the means to produce your own power – wherever you are - and experience even greater independence. Not only do you have a Fischer Panda generator on board, you also have worldwide support from the Fischer Panda Team. Please take the time to read this and find how we can support you further.

### Installation Approval and Warranty

Every generator has a worldwide warranty. You can apply for this warranty through your dealer when the installation is approved. If you have purchased an extended warranty, please ensure that it is kept in a safe place and that the dealer has your current address. Consult your dealer about warranty options especially if you have purchased a used generator. He will be able to advise about authorised Fischer Panda Services worldwide.

### Service and Support

To ensure that your generator operates reliably, regular maintenance checks and tasks as specified in this manual must be carried out. Fischer Panda can supply Service Kits which are ideal for regular servicing tasks. We only supply the highest quality components which are guaranteed to be the RIGHT parts for your generator. Service “Plus” Kits are also available and ideal for longer trips where more than one service interval may be required.

If you require assistance – please contact your Fischer Panda Dealer. Please do not attempt to undertake any repair work yourself, as this may affect your generator warranty. Your dealer will also be able to assist in finding your nearest Fischer Panda service station. Your nearest service station can also be found in our Global Service Network which can be downloaded from our homepage.

### Product Registration

Please take the time to register your Fischer Panda Generator on our website at

<http://www.fischerpanda.de/mypanda>

By registering, you will ensure that you will be kept up to date on any technical upgrades or specific information on the operation or servicing of your generator. We can even let you know about new Fischer Panda products – especially helpful if you are planning to upgrade or expand your installation at a later date.

### Fischer Panda Quality - Tried and Tested

DIN-certified according DIN ISO 9001

**Thank you for purchasing a Fischer Panda Generator.**

**Your Fischer Panda Team**



# 1. General information and regulations

## 1.1 Safety First

---

Warning signs are used in this manual when there is a risk of injury or death when carrying out certain maintenance or operating procedures. The instructions marked in this way must always be read carefully and followed.

### **Danger for life! Working at a running generator can result in severe personal injury.**

The generator can be equipped with a automatic start device. This means, an external signal may trigger an automatic start-up. To avoid an unexpected starting of the generator, the starter battery must be disconnected before working at the generator.

### **Danger! Automatic start-up**



### **Improper installation can result in severe personal injuries or material damage.**

- Always undertake installation work when the generator is switched off.
- Ensure there is sufficient installation clearance before start working.
- Ensure tidiness and cleanliness at the workplace. Loose components and tools lying around or on top of each other are sources of accidents.
- Only perform installation work using commercially available tools and special tools. incorrect or damaged tools can result injuries.

### **Warning! Risk of injury**



### **Oil and fuel vapours can ignite on contact with ignition sources. Therefore:**

- No open flames during work on the generator.
- Do not smoke.
- Remove oil and fuel residues from the generator and floor.

### **Warning! Danger of fire**



### **Contact with engine oil, antifreeze and fuel can result in damage to health. Therefore:**

- Avoid skin contact with engine oil, fuel and antifreeze.
- Remove oil and fuel splashes and antifreeze from the skin immediately.
- Do not inhale oil and fuel vapours.

### **Danger! Danger of poisoning**



### **Danger for Life. Improper handling, operation, installation and maintenance can result in severe personal injury and/or material damage.**

*Electrical voltages above 48 volts (battery chargers greater than 36 volts) are always dangerous to life). The rules of the respective regional authority must be adhered to. Only an electrician may carry out installation of the electrical connections for safety reasons.*

### **Attention! Danger to Life - High voltage**





**Generator, oil and antifreeze can be hot during/after operation. Risk of severe burns.**

**Warning! Hot surface/material**



**Batteries contain diluted sulphuric acids and bases**

Incorrect use can warm up and burst the batteries. Diluted sulphuric acid / base can escape. Under unfavourable conditions there is a risk of explosion

**Warning!**



*Observe the instructions from your battery manufacturer.*

**During Installation/maintenance personal protective equipment is required to minimize the health hazards.**

**Instruction! Personal protective equipment necessary.**

- Protective clothing
- safety boots
- protective gloves
- ear defender
- goggles

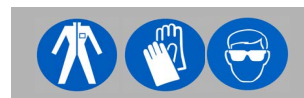

**Disconnect all load during the work at the generator to avoid damages at the load.**

**Attention! Disconnect all load**



## 1.2 Environmental protection

---

**National exhaust emission regulations must be verified with engine specification.**

**Environmental protection!**

**Engine liquids/batteries are harmful for the environment.**



Collect discharged engine liquids and dispose it properly.

Batteries should be disposed properly.



---

## 1.3 Customer registration and guarantee

---

Use the advantages of registering your product:

- you will receive a Guarantee Certificate after approval of your installation data
- you will receive extended product information that may be relevant to safety.
- You will receive free upgrades as necessary.

Additional advantages:

Based on your complete data record, Fischer Panda technicians can provide you with fast assistance, since 90 % of the disturbances result from defects in the periphery.

Problems due to installation errors can be recognized in advance.

### 1.3.1 Technical support

---

Technical Support via the Internet: [info@fischerpanda.de](mailto:info@fischerpanda.de)

### 1.3.2 Caution, important information for start-up!

---

1. The commissioning log shall be filled in immediately after initial operation and shall be confirmed by signature.
2. The commissioning log must be received by Fischer Panda GmbH at Paderborn within 4 weeks of initial operation.
3. After receiving the commissioning log, Fischer Panda will make out the official guarantee certificate and send it to the customer.
4. If warranty claims are made, the document with the guarantee certification must be submitted.

If the above requirements are not or only partly fulfilled, the warranty claim shall become void.



## 1.4 Safety Instructions - Safety First!

---

### 1.4.1 Safe operation

---

Careful handling of the equipment is the best insurance against an accident. Read the manual diligently, and make sure you understand it before starting up the equipment. All operators, regardless of their experience level, shall read this manual and additional pertinent manuals before commissioning the equipment or installing an attachment. The owner shall be responsible for ensuring that all operators receive this information and are instructed on safe handling practices.



### 1.4.2 Observe safety instructions!

---

Read and understand this manual and the safety instructions on the generator before trying to start up and operate the generator. Learn the operating practices and ensure work safety. Familiarise yourself with the equipment and its limits. Keep the generator in good condition.

### 1.4.3 Personal protective clothing (PPE)

---

For maintenance and repair work on the equipment, **do not** wear loose, torn, or ill-fitting clothing that may catch on protruding parts or come into contact with pulleys, cooling disks, or other rotating parts, which can cause severe injury.



Wear appropriate safety and protective clothing during work.

Do not operate the generator while under the influence of alcohol, medications, or drugs.



Do not wear head phones or ear buds while operating, servicing, or repairing the equipment.



### 1.4.4 Cleanliness ensures safety

---

Keep the generator and its environment clean.

Before cleaning the generator, shut down the equipment and secure it against accidental start-up. Keep the generator free from dirt, grease, and waste. Store flammable liquids in suitable containers only and ensure adequate distance to the generator. Check the lines regularly for leakage and eliminate leaks immediately as applicable.





## 1.4.5 Safe handling of fuels and lubricants

Keep fuels and lubricants away from naked fire.

Before filling up the tank and/or applying lubricant, always shut down the generator and secure it against accidental start-up.



Do not smoke and avoid naked flame and sparking near fuels and the generator. Fuel is highly flammable and may explode under certain conditions.

Refuel in well-ventilated open spaces only. If fuel/lubricant was spilled, eliminate fluids immediately.

Do not mix diesel fuel with petrol or alcohol. Such a mixture can cause fire and will damage the generator.



Use only approved fuel containers and tank systems. Old bottles and canisters are not adequate.

## 1.4.6 Exhaust fumes and fire protection

Engine fumes can be hazardous to your health if they accumulate. Ensure that the generator exhaust fumes are vented appropriately (leak-proof system), and that an adequate fresh air supply is available for the generator and the operator (forced ventilation).



Check the system regularly for leakage and eliminate leaks as applicable.

Exhaust gases and parts containing such fumes are very hot; they may cause burns under certain circumstances. Always keep flammable parts away from the generator and the exhaust system.

To prevent fire, ensure that electrical connections are not short-circuited. Check regularly that all lines and cables are in good condition and that there is no chafing. Bare wires, open chafing spots, frayed insulation, and loose cable connections can cause dangerous electric shocks, short-circuit, and fire.



The generator shall be integrated in the existing fire safety system by the operating company.

### CALIFORNIA

#### Proposition 65 Warning

Diesel engine exhaust and some of its constituents are known to the State of California to cause cancer, birth defects, and other reproductive harm.





## 1.4.7 Safety precautions against burns and battery explosions

---

The generator and its cooling agents and lubricants as well as the fuel can get hot while the generator is operated. Use caution around hot components such as parts containing exhaust fumes, radiator, hoses, and engine block during operation and after the generator was shut down.



The cooling system may be pressurised. Open the cooling system only after letting the engine and the coolant cool down. Wear appropriate protective clothing (e.g. safety goggles, gloves).



Prior to operation, ensure that the cooling system is sealed and that all hose clamps are tightened.

The battery represents an explosion hazard, this applies both to the starter battery and the battery bank of the AGT generators. While batteries are being charged, a hydrogen-oxygen mixture is generated, which is highly explosive (electrolytic gas).



Do not use or charge batteries if the fluid level is below the MINIMUM marking. The life span of the battery is significantly reduced, and the risk of explosion increases. Refill to a fluid level between maximum and minimum level without delay.

Especially during charging, keep sparks and naked fire away from the batteries. Ensure that the battery terminals are tightly connected and not corroded to avoid sparking. Use an appropriate terminal grease.



Check the charge level with an adequate voltmeter or acid siphon. Contact of a metal object across the terminals will result in short-circuiting, battery damage, and high explosion risk.

Do not charge frozen batteries. Heat the batteries to +16 °C (61 °F) prior to charging.

## 1.4.8 Protect your hands and body from rotating parts!

---

Always keep the capsule closed while operating the generator.

To check the V-belt tension, always shut down the generator.



Keep your hands and body away from rotating parts such as V-belt, fans, pulleys, and flywheel. Contact can cause severe injury.

Do not run the engine without the safety devices in place. Prior to start-up, mount all safety devices securely and check for proper attachment and function.

## 1.4.9 Anti-freeze and disposal of fluids

---

Anti-freeze contains toxic substances. To prevent injury, wear rubber gloves and wash off any anti-freeze immediately in case of skin contact. Do not mix different anti-freeze agents. The mixture may cause a chemical reaction generating harmful substances. Use only anti-freeze that was approved by Fischer Panda.



Protect the environment. Collect drained fluids (lubricants, anti-freeze, fuel), and dispose of them properly. Observe the local regulations for the respective country. Ensure that no fluids (not even very small quantities) can drain into the soil, sewers, or bodies of water.





## 1.4.10 Implementation of safety inspections and maintenance

---

Disconnect the battery from the engine before performing service work. Affix a sign to the control panel - both the main and the corresponding slave panel - with the instruction "DO NOT START UP - MAINTENANCE IN PROGRESS" to prevent unintentional start-up.



To prevent sparking due to accidental short-circuiting, always remove the earthing cable (-) first and reconnect it last. Do not start work until the generator and all fluids and exhaust system parts have cooled down.

Use only suitable tooling and appliances and familiarise yourself with their functions to prevent secondary damage and/or injury.



Always keep a fire extinguisher and a first aid box handy while performing maintenance work.

## 1.5 Warning and instruction signs

---

---

Keep warning and instruction signs clean and legible.

Clean the signs with water and soap and dry them with a soft cloth.

Immediately replace damaged or missing warning and instruction signs. This also applies to the installation of spare parts.

### 1.5.1 Special instructions and hazards of generators

---

The electrical installations may only be carried out by trained and qualified personnel!



**The generator must not be operated with the cover removed.**

If the generator is being installed without a sound insulation capsule, it must be ensured that all rotating parts (belt-pulley, belts etc.) are covered and protected so that there is no danger to life and body!



If a sound insulation covering will be produced at the place of installation, then easily visible signs must show that the generator must only be switched on while the capsule is closed.



All servicing, maintenance, or repair work may only be carried out when the motor is not running.

Electrical voltages above 50 volts are always dangerous to life. The rules of the respective regional authority must be adhered to during installation. For safety reasons, only an electrician may carry out the installation of the electrical connections of the generator.



### 1.5.1.1 Protective conductor and potential equalisation:

Electric voltage above 50 V may be life-threatening. For this reason systems are grounded with a protective conductor. In connection with a RCD the current supply will be disconnected in case of a failure.

Appropriate safety precautions like the RCD and corresponding fuses have to be provided by the customer to guarantee a safe operation of the generator.

### 1.5.1.2 Protective conductor for Panda AC generators:

The generator is „earthed“ as a standard (centre and ground are interconnected in the generator terminal box by a shunt). This is a basic first-level safety measure, which offers protection as long as no other measures are installed. Above all, it is designed for delivery and a possible test run.



This „neutralisation“ (Protective Earthing Neutral - PEN) is only effective if all parts of the electrical system are jointly „earthed“ to a common potential. The shunt can be removed if this is necessary for technical reasons and another protective system has been set up instead.

**While the generator is being operated, the full voltage is applied to the AC control box, as well. Therefore, it is essential to ensure that the control box is closed and secured against touch while the generator is running.**



**The battery must always be disconnected if work on the generator or electrical system is to be carried out, so that the generator cannot be started up unintentionally.**

### 1.5.1.3 Switch off all loads while working on the generator

All loads must be disconnected prior to working on the generator to avoid damage to the devices. In addition, the semiconductor relays in the AC control box must be disconnected in order to avoid the booster capacitors being activated during set-up. The negative terminal of the battery must be disconnected.

Capacitors are required to run the generator. These have two varying functions:

- A) The working capacitors
- B) The booster capacitors

Both groups are located in a separate AC control box.

Capacitors store electrical energy. High voltages may remain across the capacitor contacts even after they have been disconnected from the mains. As a safety precaution, do not touch the contacts. If the capacitors must be replaced or inspected, the contacts shall be short-circuited by connecting an electrical conductor to discharge potentially remaining potential differences.

If the generator is switched off normally, the working capacitors are automatically discharged via the winding of the generator. The booster capacitors are discharged by means of internal discharge resistors.

For safety reasons, all capacitors must be discharged through short-circuiting before work is carried out on the AC control box.

### 1.5.1.4 Potential equalisation for Panda AGT DC generators

For further information specific to your generator, see the chapter installation.



### 1.5.1.5 Safety instructions concerning cables

#### Cable types

It is recommended to use cables that are in compliance with the standard UL 1426 (BC-5W2) with type 3 (ABYC section E-11).

#### Cable cross-section

The cable shall be selected taking into account the amperage, cable type, and conductor length (from the positive power source connection to the electrical device and back to the negative power source connection).

#### Cable installation

It is recommended to install a self-draining cable conduit classified as V-2 or higher in compliance with UL 94 in the area of the cable guide inside the capsule. It must be ensured that the cable guide is not routed along hot surfaces such as the exhaust manifold or the engine oil drain screw but instead is installed free from any influence due to friction and crushing.

## 1.5.2 General safety instructions for handling batteries

**These instructions shall apply in addition to the instructions of the battery manufacturer:**

- While you are working on the batteries, a second person should be within earshot to help you if necessary.
- Keep water and soap ready in case battery acid is burning your skin.
- Wear eye protection and protective clothing. Do not touch your eyes while handling batteries.
- If you have acid splashes on the skin or clothing, wash them out with lots of water and soap.
- If acid sprays into your eyes, immediately flush them with clean water until no more burning is felt. Immediately seek medical assistance.
- Do not smoke near the batteries. Avoid naked fire. The area around batteries is a potentially explosive atmosphere.
- Ensure that no tools are dropped on the battery terminals; cover them as necessary.
- Do not wear jewellery or watches on your arms during installation that might short-circuit the battery. Otherwise, there is a risk of skin burns.
- Protect all battery contacts against accidental contact.
- For battery banks: Use only deep cycle batteries. Starter batteries are not suitable. Lead-acid gel batteries are recommended. They are maintenance-free, cycle stable, and do not release gases.
- Never charge a frozen battery.
- Avoid battery short-circuits.
- Ensure proper ventilation of the battery to vent gases that may be released.
- Battery connection terminals must be checked for proper seating before operation.
- Battery connection cables shall be installed with utmost care and shall be checked for excessive heating under load. Check the battery near vibrating components regularly for chafing and insulation defects.



**ATTENTION! For battery charger generators (Fischer Panda AGT-DC)!**



**Prior to installation, verify that the voltage of the battery bank complies with the output voltage of the generator.**





## 2. In case of Emergency First Aid

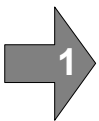
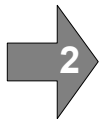
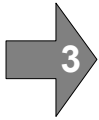

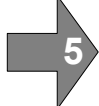
	First Aid in case of accidents by electrical shocks 5 Safety steps to follow if someone is the victim of electrical shock	
	Do not touch the injured person while the generator is running.	
	Switch off the generator immediately.	
	If you cannot switch off the generator, pull, push, or lift the person to safety using a wooden pole, rope or some nonconducting material.	
	Call an emergency doctor as soon as possible.	
	Immediately start necessary first aid procedures.	





## 2.1 WHEN AN ADULT STOPS BREATHING

**DO NOT attempt to perform the rescue breathing techniques provided on this page, unless certified. Performance of these techniques by uncertified personnel could result in further injury or death to the victim.**

**Warning:**

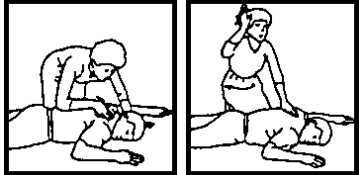
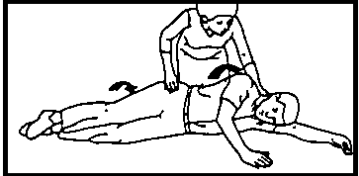
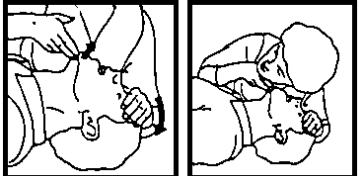

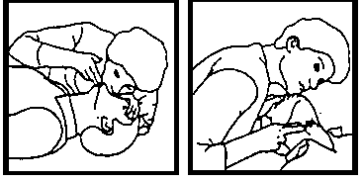
<p><b>1</b> Does the Person Respond? Tap or gently shake victim. Shout, "Are you OK?"</p>		<p><b>2</b> Shout, "Help!" Call people who can phone for help.</p>
<p><b>3</b> Roll Person onto Back. Roll victim towards you by pulling slowly.</p>		
<p><b>4</b> Open Airway. Tilt head back, and lift chin. Shout, "Are you OK?"</p>		<p><b>5</b> Check for Breathing. Look, listen, and feel for breathing for 3 to 5 seconds.</p>
<p><b>6</b> Give 2 Full Breaths. Keep head tilted back. Pinch nose shut. Seal your lips tight around victim's mouth. Give 2 full breaths for 1 to 1½ seconds each.</p>		
<p><b>7</b> Check for Pulse at side of Neck. Feel for pulse for 5 to 10 seconds.</p>		<p><b>8</b> Phone EMS for Help. Send someone to call an ambulance.</p>
<p><b>9</b> Begin Rescue Breathing. Keep head tilted back. Lift chin. Pinch nose shut. Give 1 full breath every 5 seconds. Look, listen, and feel for breathing between breaths.</p>		<p><b>10</b> Recheck Pulse Every Minute. Keep head tilted back. Feel for pulse for 5 to 10 seconds. If victim has pulse, not breathing, continue rescue breathing. If no pulse, begin CPR.</p>



---

## 3. Basics

### 3.1 Intended use of the machine

---

---

The machine is only for use as an fixed installed electric generator in following applications:

- motor vehicles
- trailers and mobile containers
- inland water vessels/river boats
- ocean-going vessels

The power should produced and supplied in the on-board grid for off grid use only. Other or further use is not intended.

For the intended use, the designated limits of the machine and all safety related parameter must be respected. The limits of the machine should not be exceeded.

### 3.2 Purpose of the manual and description of the definitions of the trained persons/operators/users

---

---

This manual contains the working instructions and operating guidelines for the owner and user of Fischer Panda generators.

The manual is the base and the guideline for the correct installation and maintenance of Fischer Panda generators. It does not substitute the technical evaluation and should be used as an example guide only. The installation must be undertaken and proved by a suitable qualified/trained person and should be in accordance with the law as required by the country and special situation. All work has to be undertaken according to the state of the technology.

#### 3.2.1 Trained persons

---

**Qualified persons for the mechanical components are motor mechanics or persons with similar qualification and training.**

**Trained persons for the electrical components are electricians or persons with similar qualification and training.**

After the installation the trained person has to instruct the operator/owner about the operation and maintenance of the generator. This must include the hazards of the generator use.

#### 3.2.2 Operator/Owner

---

**The operator is responsible for the operation of the generator.**

After the installation, the operator/owner must be instructed concerning the operation and maintenance of the generator. This has to include the hazards during operation of the generator, different operating conditions, and instructions for the maintenance.

The operator/owner must read and follow the manual and must respect the hazard notes and safety instructions.



### 3.2.3 User

---

**Users are persons, established by the operator/owner, to operate the generator.**

The operator/owner has to ensure that the user has read and understood the manual and that all hazard notes and safety instructions are respected. The user must be instructed by the operator/owner regarding his activity at the generator, especially concerning the maintenance.

## 3.3 Components of the xGenerator

---

### 1. Panda xGenerator

*representative picture*

Fig. 3.3-1: Panda xGenerator



### 2. Control Panel Panda fpControl

*representative picture*

Fig. 3.3-2: xControl panel







## 6. Fischer Panda manual

Fig. 3.3-6: Manual

The Fischer Panda manual comprises the following components:

- a.- Transparent envelope with general information, warranty terms, installation certificates, and service list.
- b.- Generator manual
- c.- Spare parts catalogue „Installation & Service Guide“
- d.- Engine manual from the engine manufacturer
- e.- Generator circuit diagram

*representative picture*



## 3.4 Range of operation

---

Reliable power supply on vehicles.

## 3.5 Panda transport box

---

### 3.5.1 Bolted Fischer Panda transport box

---

1. Remove the bolts for cover / sidewalls
2. Remove the cover
3. Remove the loose accessories
4. Remove the bolts for sidewalls / floor pallet
5. Remove the sidewalls
6. Open the generator attachment

### 3.5.2 Fischer Panda transport box with metal tab closure

---

1. Bend up the metal tab closures on the transport box lid
2. Remove the cover
3. Remove the loose
4. Bend open the metal tab closures at the bottom of the transport box
5. Remove the sidewalls
6. Open the generator attachment

### 3.6 Opening the MPL sound insulation capsule

To open the sound insulation capsule, the closures must be rotated roughly 180° counter-clockwise. Use a flat head screwdriver. Pull the sidewalls out by gripping into the slots.



representative picture

Closure locked

representative picture

Fig. 3.6-1: Sound insulation capsule, side part



Fig. 3.6-2: Closure locked





## Closure open

representative picture

Fig. 3.6-3: Closure open



### 3.6.1 Opening the GFK sound insulation capsule

#### GFK sound insulation capsule with lash closures

representative picture

Fig. 3.6-1: Lash closures



To open the lash closures pull the handle in arrow direction and lift the lash of the closure pin. After lifting off the lashes, the sound isolation cover upper part can be removed.

representative picture

Fig. 3.6-2: Lash closures



## 3.7 Transport and loading/unloading

---

### 3.7.1 Transporting the generator

---

- The generator must always be upright for transport.
- For transport, the Fischer Panda transport box shall be used for the generator. The generator shall be securely attached to the bottom of the box.
- For loading/unloading, an adequate industrial truck shall be used.
- Depending on the transport distance (e.g. air cargo), the generator fluids (coolant, engine oil, fuel) may have to be drained. The corresponding instructions and warnings must be fitted to the transport packaging.

### 3.7.2 Loading/unloading of the generator

---

For loading/unloading the generator, appropriate ring eye bolts shall be installed in the holes in the support rails. The load bearing capacity of each ring eye bolt must at least equal the generator weight.

**An adequate lifting yoke shall be used for transport/loading.**

*Fig. 3.7.2-1: Lifting yoke (example)*



## 3.8 Special service instructions and measures for extended machine downtimes and decommissioning

---

The decommissioning and storage must be undertaken and proved regarding the operation and storage situation. **Note:**

**Fischer Panda takes no responsibility for damages through wrong decommissioning and storage.**

Downtimes are categorised in the following groups:

- Short downtime (1 to 3 months)
- Medium term downtime / hibernation (3 to 6 months)
- Extended downtime / decommissioning (more than 6 months)





### 3.8.1 Instructions for the starter battery for extended downtimes

---

#### Starter batteries

Self-discharge of batteries is a physical and chemical process and cannot be avoided even if the battery is disconnected

- For extended downtimes, the battery shall be disconnected from the genset.
- Charge battery regularly. Observe instructions of the battery manufacturer.

Depending on the battery type, check the acid level before charging and refill each cell up to the marking using distilled water as necessary.

Modern starter batteries are typically maintenance-free.

#### **Deep discharge will damage the battery and can render it unusable.**

Keep battery clean and dry. Clean battery poles (+ and -) and terminals regularly and coat with acid-free and acid-resistant grease. During assembly, ensure good contact of the terminal connections.

General limits for lead-acid batteries:

2.1 V / cell corresponds with full battery (charged).

1.95 V / cell corresponds with empty battery - recharge.

For a 12 V battery, the following applies:

- 11.7 V lower open-circuit voltage (battery empty), recharge battery.
- 12.6 V upper open-circuit voltage (full battery) - trickle charge full battery at 13.2 V.

For a 24 V battery, the following applies:

- 23.4 V lower open-circuit voltage (battery empty), recharge battery.
- 25.2 V upper open-circuit voltage (full battery) - trickle charge full battery at 26.4 V.

*These values are based on a battery temperature of 20-25 °C. Observe the instructions from the battery manufacturer.*

#### **Fischer Panda recommends:**

- Install battery circuit breaker and switch to OFF on the machine. (Cutting the battery circuit.)
- Secure the battery plus terminal close to the battery.
- Regularly check contacts for corrosion.

#### Note: Information starter battery



#### Note: Starter battery recommendation



### 3.8.2 Measures for short downtimes

---

Short downtime (1 to 3 months)

- Measure battery charge status based on open-circuit voltage.
- During downtimes >7 days, disconnect battery (e.g. battery main switch to position 0).
- Check the battery within 2 months and allow the engine to warm up for min. 10 min.
- Fill fuel tank to 100% (level to full).

### 3.8.3 Measures for medium term downtimes / hibernation

---

Medium term downtimes (3 to 6 months)



### 3.8.3.1 Courses for preservation:

- Check battery charge status and recharge regularly, roughly every 2 months, as necessary. Observe instructions of the battery manufacturer.
- Check cooling water anti-freeze level and refill as necessary.  
The anti-freeze agent must not be older than 2 years. The anti-freeze content shall be between 40 % and 60 % to ensure corrosion protection of the cooling water circuit. Top off coolant if necessary.  
If the cooling water is drained, e.g. after engine surface protection is applied, no water may remain inside the engine during the downtime. The control unit must be marked accordingly with a note specifying "NO COOLING WATER".
- Drain engine oil as specified. Refill engine with preservative oil to the max. level on the oil dipstick.
- Drain diesel from tank and refill with a protective mixture (90 % diesel and 10 % preservative oil) (level to full).

#### Crank engine without start.

- Dismount V-belt as specified, wrap and store in a dry location. Protect against UV radiation.

#### Cover alternator apertures.

#### Attention!

Cleaning fluids and preservatives must not enter the alternator. Risk of destroying the alternator.



- Clean engine as per manufacturer's instructions.
- Spray engine parts and V-belt disks with preservative.
- Clean air filter housing and spray with preservative (metal housing only).
- Close off intake and exhaust apertures (e.g. with tape or end caps).

#### Before recommissioning, remove preservatives and protective measures.

#### Attention!



### 3.8.3.2 Measures for removing surface protection after medium term downtimes (3 to 6 months).

- Check battery charge status and recharge if necessary. Observe instructions of the battery manufacturer.
- Check cooling water anti-freeze level and cooling water level and refill as necessary.
- Drain engine oil. Replace oil filter and engine oil as per the specification.
- Remove preservatives from the engine with petroleum spirit.
- Degrease V-belt disks and mount V-belt according to instructions. Check V-belt tension!
- If applicable, open turbocharger oil pressure line and fill clean engine oil into channel.
- Hold engine stop lever in zero delivery position and crank engine manually several times.
- Clean air filter housing with petroleum spirit, check air filter and replace if necessary.
- Remove covers from exhaust aperture and intake apertures.
- Connect battery. Close battery main switch.
- Hold stop lever on generator motor in neutral position and crank starter for approx. 10 seconds. Then, pause for 10 seconds. Repeat this procedure 2 times.
- Perform visual check of the generator similar to initial commissioning and start up generator.



### 3.8.4 Measures for extended downtimes / decommissioning

Downtimes (more than 6 months)

#### 3.8.4.1 Courses for preservation:

- Check battery charge status and recharge regularly, roughly every 2 months, as necessary. Observe instructions of the battery manufacturer.
- Check cooling water anti-freeze level and refill as necessary.

The anti-freeze agent must not be older than 2 years. The anti-freeze content shall be between 40 % and 60 % to ensure corrosion protection of the cooling water circuit. Top off coolant if necessary.

If the cooling water is drained, e.g. after engine surface protection is applied, no water may remain inside the engine during the downtime. The control unit must be marked accordingly with a note specifying "NO COOLING WATER".

- Drain engine oil as specified. Refill engine with preservative oil to the max. level on the oil dipstick.
- Drain diesel from tank and refill with a protective mixture (90 % diesel and 10 % preservative oil) (level to full).

#### Crank engine without start.

- Dismount V-belt as specified, wrap and store in a dry location. Protect against UV radiation.
- Disconnect battery. Coat terminals with acid-free grease.

#### Cover alternator apertures.

#### Attention!

Cleaning fluids and preservatives must not enter the alternator. Risk of destroying the alternator.



- Clean engine as per manufacturer's instructions.
- Spray engine parts and V-belt disks with preservative.
- Clean air filter housing and spray with preservative (metal housing only).
- Spray preservative on intake and exhaust side of exhaust turbocharger (where applicable) and reconnect the lines.
- Remove valve cover and spray inside of valve cover, valve stems, springs, rocker, etc. with preservative oil.
- Remove injection nozzle and coat cylinder surface with preservative oil. Hold stop lever in zero delivery position and crank engine manually several times. Refit injection nozzles with new seals (at an operation hour of min. 100 hours after the last change). Observe torque values.
- Spray radiator cover and tank cover or radiator cover on expansion tank lightly with preservative oil and refit.
- Close off intake and exhaust apertures (e.g. with tape or end caps).

**For storage for more than 12 months, the preservation measures shall be checked annually and supplemented as necessary.**

#### Note:



**Before recommissioning, remove preservatives and protective measures.**

#### Attention!



#### 3.8.4.2 Measures for removing surface protection after extended downtimes / recommissioning (over 6 months):

- Check battery charge status and recharge if necessary. Observe instructions of the battery manufacturer.



- Check cooling water anti-freeze level and cooling water level and refill as necessary.
- Drain engine oil. Replace oil filter and oil as per the specification.
- Remove preservatives from the engine with petroleum spirit.
- Degrease V-belt disks and mount V-belt according to instructions. Check V-belt tension!
- If applicable, open turbocharger oil pressure line and fill clean engine oil into channel.
- Hold engine stop lever in zero delivery position and crank engine manually several times.
- Clean air filter housing with petroleum spirit, check air filter and replace if necessary.
- Remove covers from exhaust aperture and intake apertures.
- Connect battery. Close battery main switch.
- Hold stop lever on generator motor in neutral position and crank starter for approx. 10 seconds. Then, pause for 10 seconds. Repeat this procedure 2 times.
- Perform visual check of the generator similar to initial commissioning and start up generator.

**Fischer Panda recommends:**

After extended downtimes, a full 150 h inspection as per the inspection list should be performed.

**Note:**





---

Leere Seite / Intentionally blank

## 4. The Panda Generator

### 4.1 Type plate at the Generator

Fig. 4.1-1: Type plate

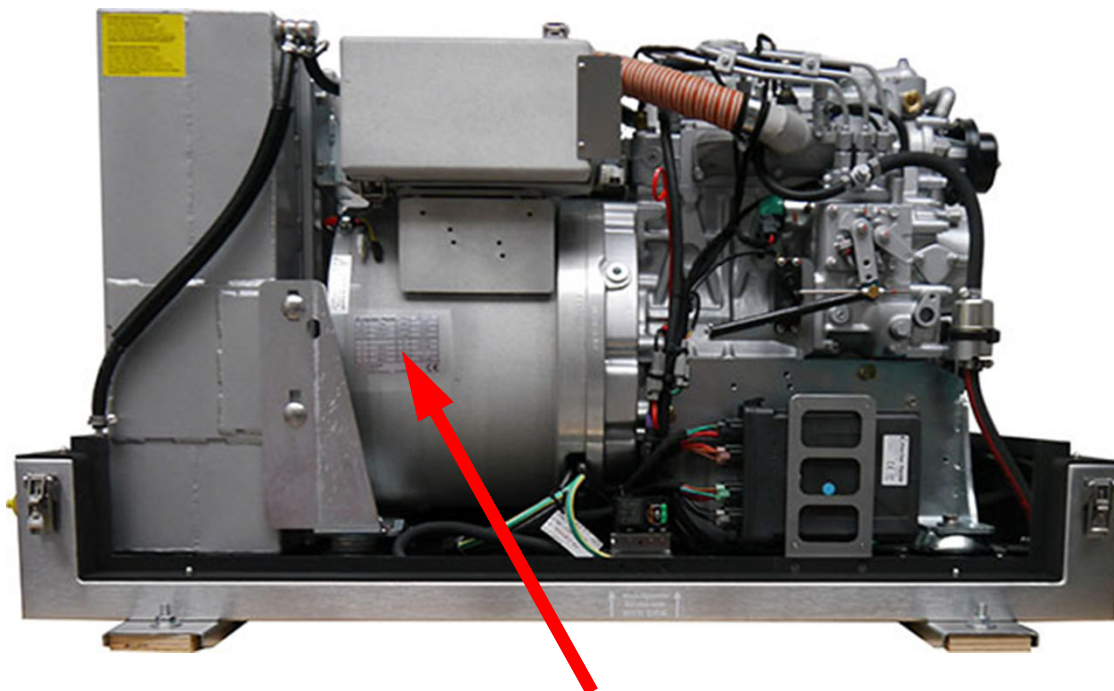

FischerPanda		S/No	
Typ		Year	
Mod.		Weight	
Art. No		T <sub>amb max</sub>	
Y		P <sub>n</sub>	
U <sub>n</sub>		S <sub>n</sub>	
f <sub>n</sub>		Cos φ	
I <sub>n</sub>		P <sub>con</sub>	
Fischer Panda GmbH Otto-Hahn-Str. 40 33104 Paderborn Germany Made in Germany www.fischerpanda.de		CE	

Fig. 4.1-2: Discription type plate

	FischerPanda	S/No		Serial number
Type description	Typ	Year		Year of manufacture
Model	Mod.	Weight		Weight
Articel number	Art. No	T <sub>amb max</sub>		Ambient temperature
Interlinking	Y	P <sub>n</sub>		Nominal real power
Nominal voltage	U <sub>n</sub>	S <sub>n</sub>		Nominal apparent power
Nominal frequency	f <sub>n</sub>	Cos φ		Nominal power factor
Nominal current	I <sub>n</sub>	P <sub>con</sub>		Electrical continuous power
Fischer Panda GmbH Otto-Hahn-Str. 40 33104 Paderborn Germany Made in Germany www.fischerpanda.de		CE		



## 4.2 Description of the Generator

### 4.2.1 Right Side View

Fig. 4.2.1-1: Right Side View

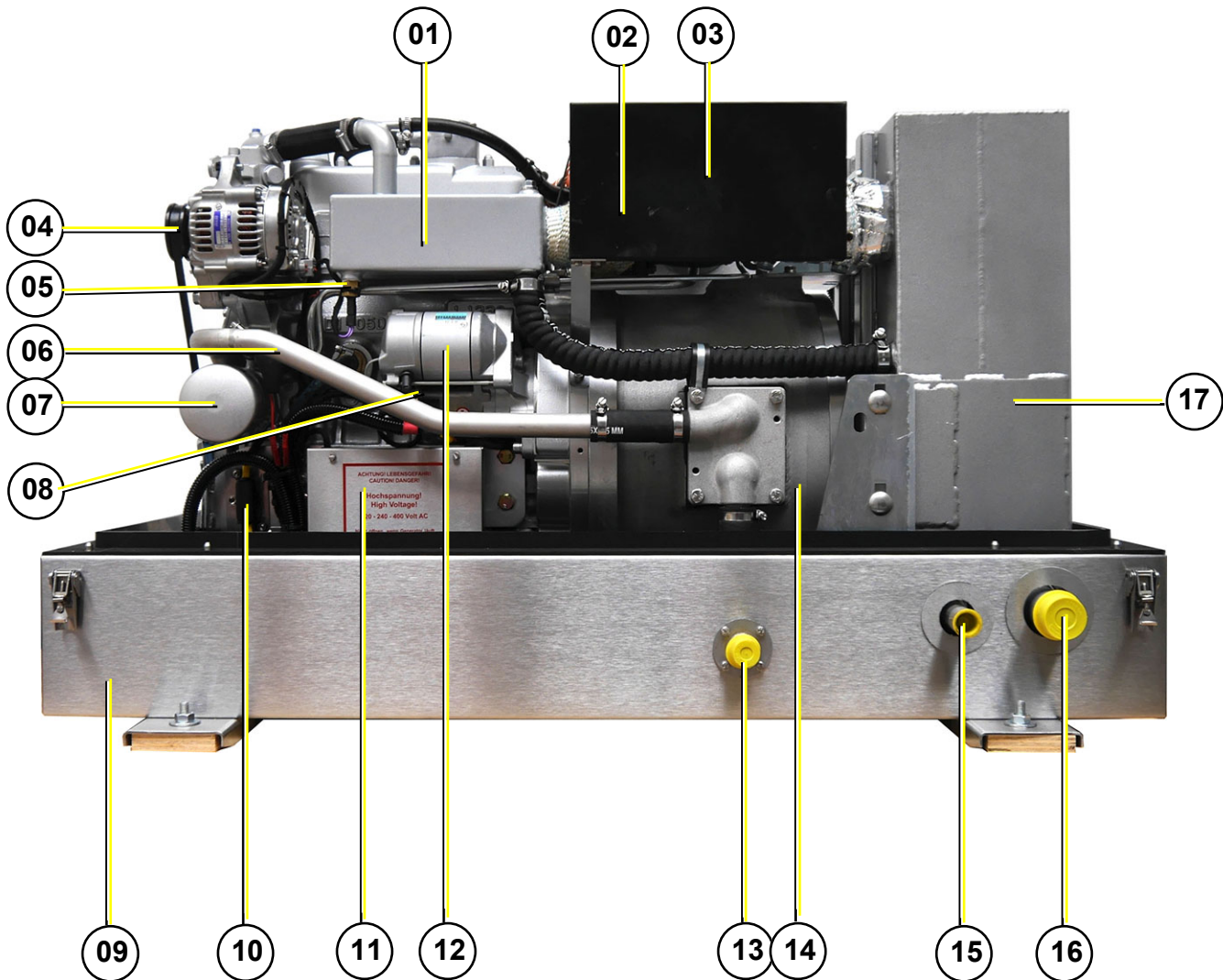

- |                                      |                                     |
|--------------------------------------|-------------------------------------|
| 01. Water-cooled exhaust elbow       | 10. DC fuse                         |
| 02. Turbo charger (optional)         | 11. Generator power terminal box    |
| 03. Compensator under heat isolation | 12. Starter motor                   |
| 04. DC-alternator                    | 13. Connection cooling water inlet  |
| 05. Thermo-sensor exhaust elbow      | 14. Generator housing with coil     |
| 06. Oil pressure switch              | 15. Connection cooling water outlet |
| 07. Oil filter                       | 16. Connection exhaust hose         |
| 08. Solenoid for starter motor       | 17. Water-cooled silencer           |
| 09. Sound cover base part            |                                     |

## 4.2.2 Left Side View

Fig. 4.2.2-1: Left side View

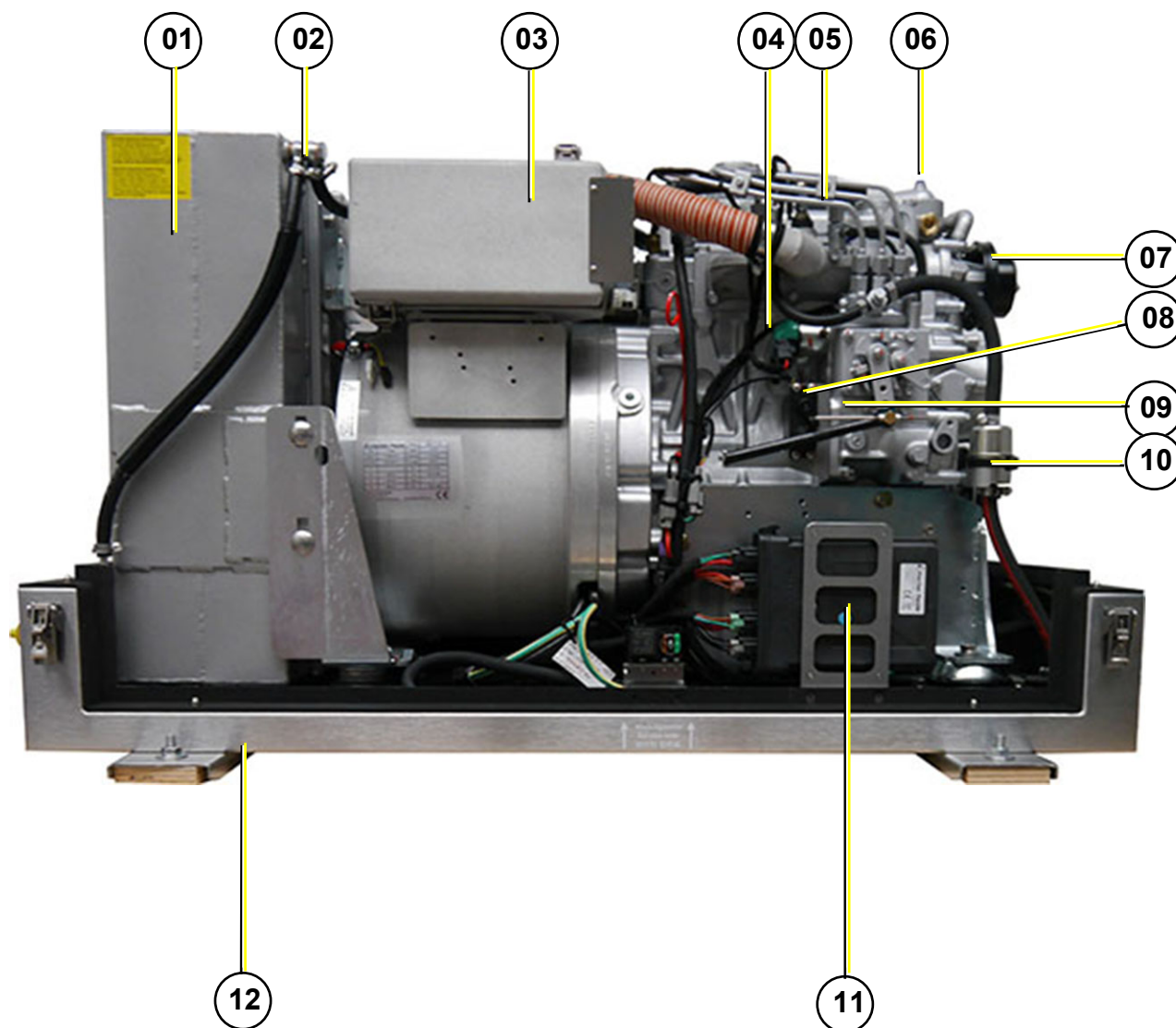

- 01. Water-cooled silencer
- 02. Ventilation screw silencer
- 03. Air suction housing with air filter
- 04. Stop solenoid
- 05. Injection nozzle
- 06. Ventilation screw thermostat housing

- 07. Pulley for internal cooling water pump
- 08. Actuator for rpm-regulation
- 09. Oil dipstick
- 10. Fuel filter
- 11. xControl ECU
- 12. Sound cover base part



### 4.2.3 Front View

Fig. 4.2.3-1: Front view

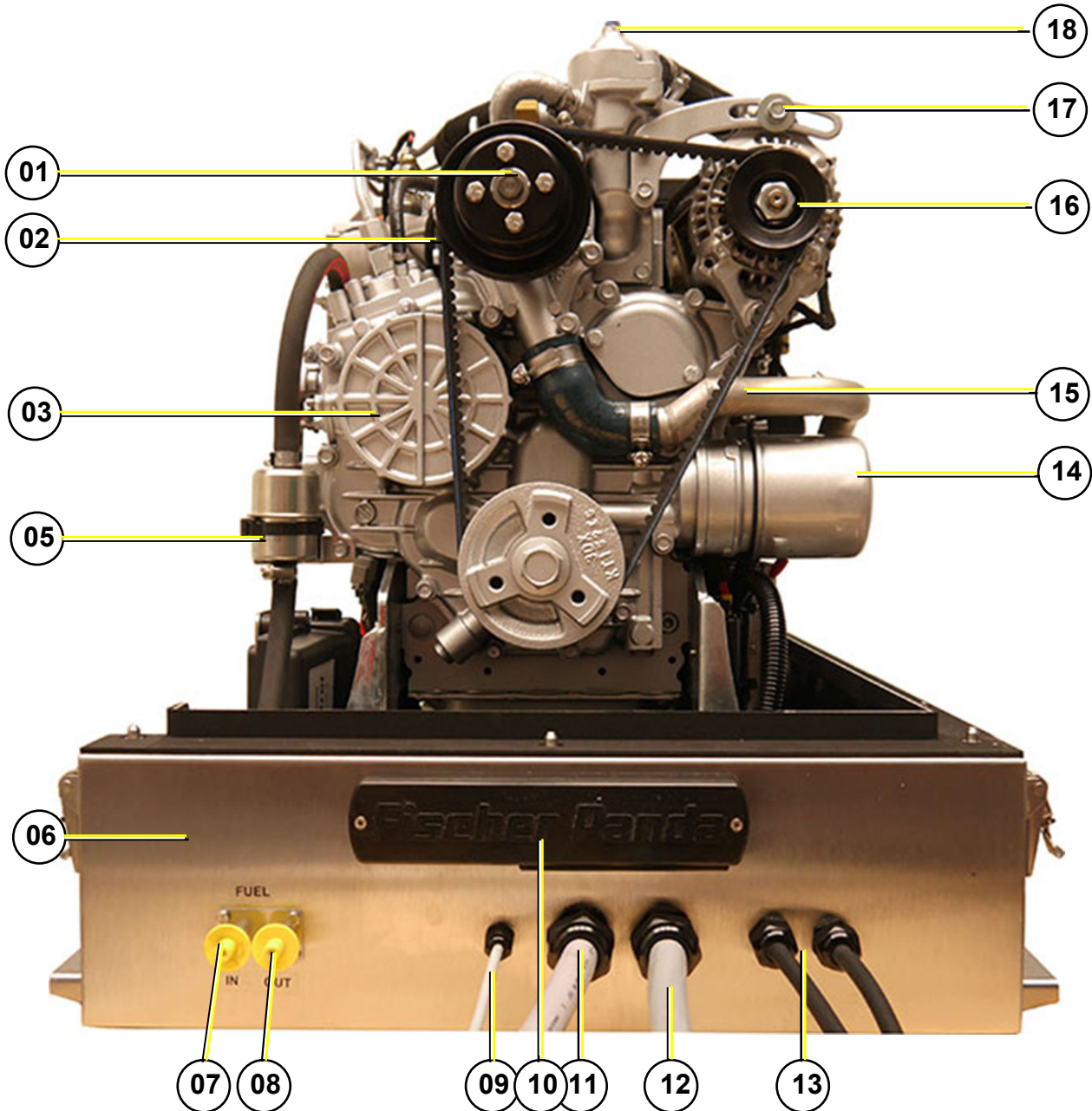

- 01. Pulley for internal cooling water pump
- 02. V-Belt
- 03. Injection pump
- 05. Fuel filter
- 06. Sound cover base part
- 07. Connection fuel in
- 08. Connection fuel out
- 09. Cable for flame start (option)
- 10. xControl connection panel

- 11. Cable AC-Control box
- 12. Cable Load
- 13. Cable for starter battery minus (-) and plus (+)
- 14. Oil filter
- 15. Cooling water pipe
- 16. DC-alternator
- 17. Clamp device for DC-alternator
- 18. Ventilation screw thermostat housing

## 4.2.4 Back View

---

Fig. 4.2.4-1: Back view

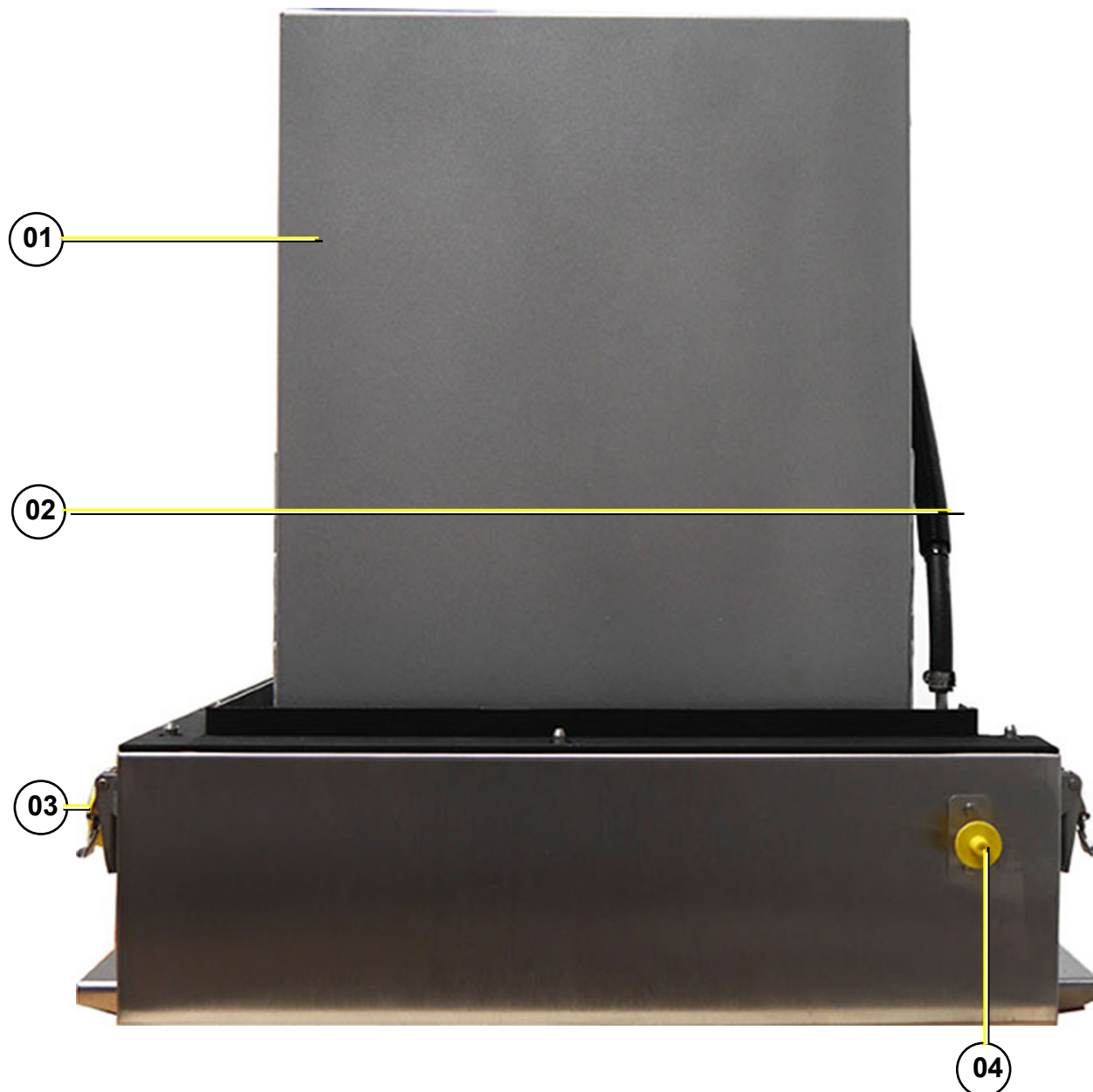

01. Water-cooled silencer

02. Return-flow external expansion tank

03. Connection exhaust hose

04. Connection external expansion tank



## 4.3 Details of functional units

### 4.3.1 xControl panel

The control panel is fitted with various monitoring functions, which increase functional reliability and operating safety of the generator. Various parts of the generator are monitored with sensors which, when triggered, generate an error message and can shut down generator operation under certain circumstances to prevent damage.

Fig. 4.3-1: xControl CP-G front side



Fig. 4.3.1-2: xControl CP-G reverse side



See xControl manual for details!

Notice!



### 4.3.2



### 4.3.3 The cooling system

Fig. 4.3.3-1: The cooling system

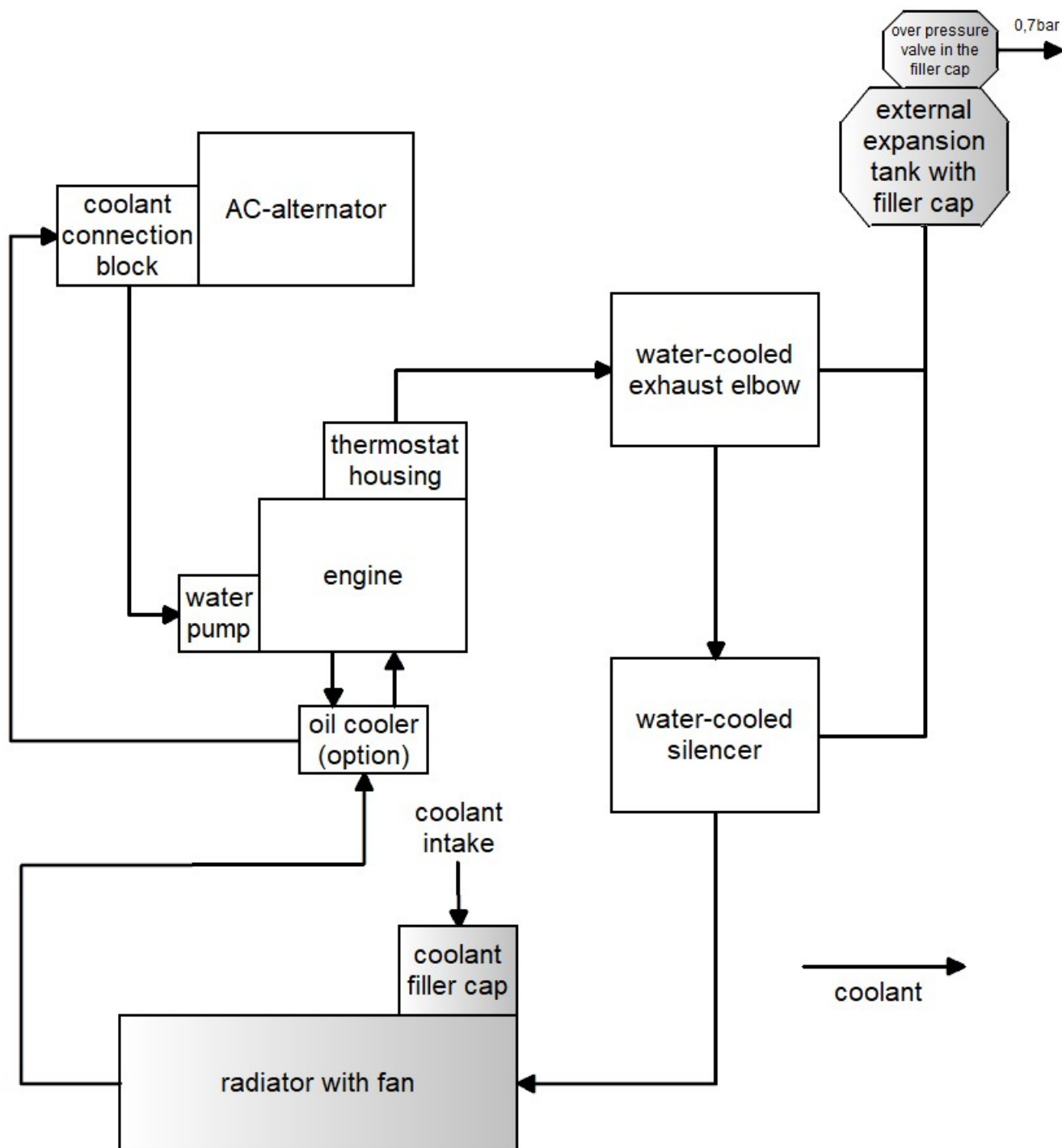



### 4.3.4 The fuel and combustion air system

Fig. 4.3.4-1: The fuel and combustion air system

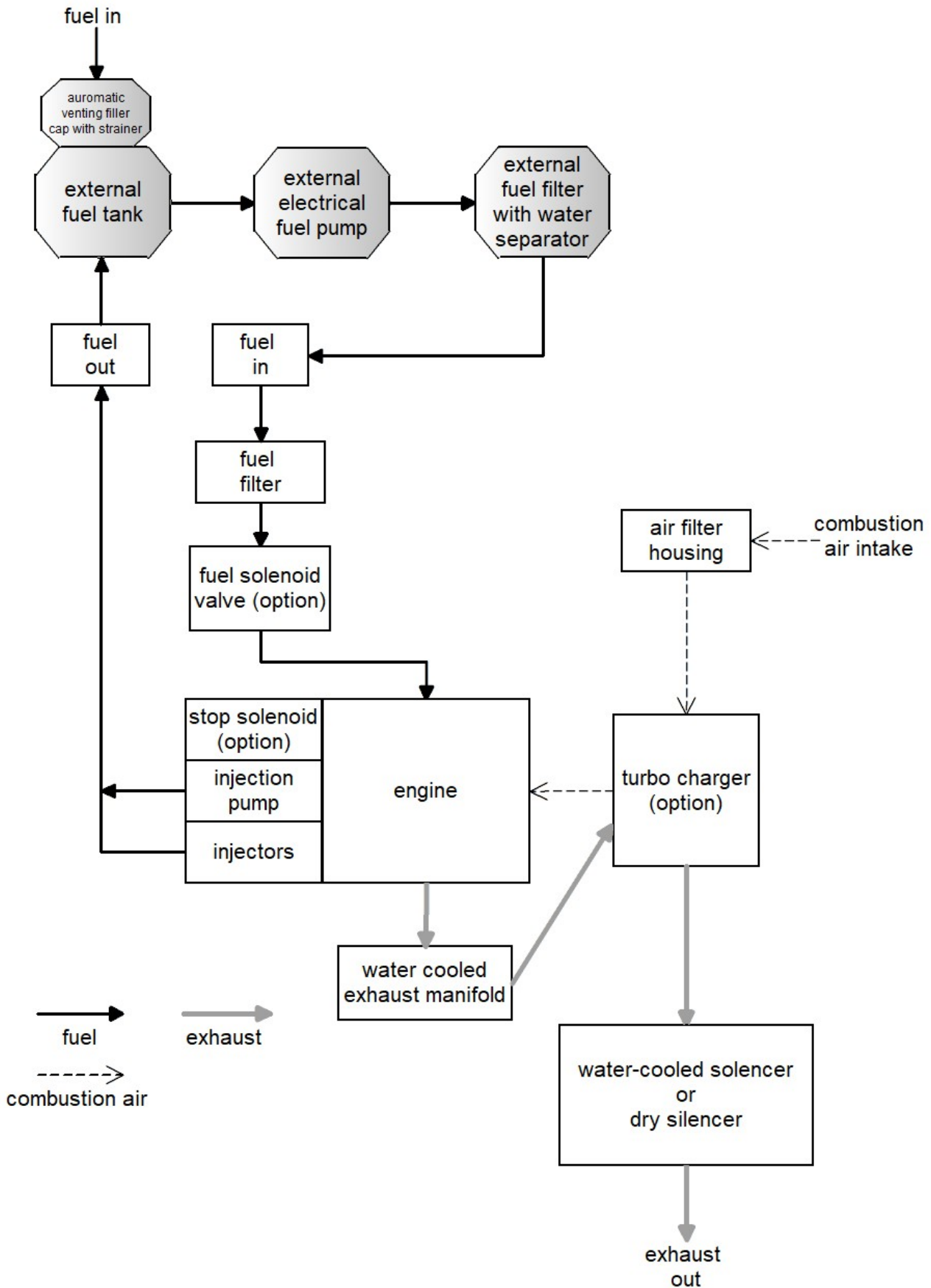

## 4.3.5 Sensors and switches for operating surveillance

### Thermo-sensor at cylinder head

The thermo-sensor at the cylinder head serves the monitoring of the generator temperature.

Fig. 4.3.5-1: Thermo-switch cylinder head

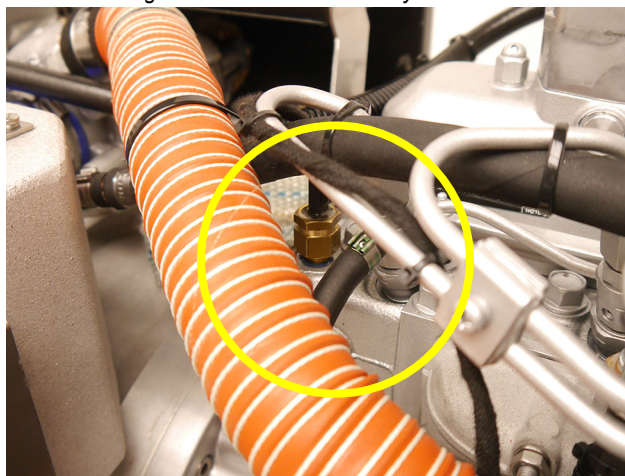

### Thermo-sensor at water-cooled exhaust elbow

Fig. 4.3.5-2: Thermo-switch at exhaust elbow

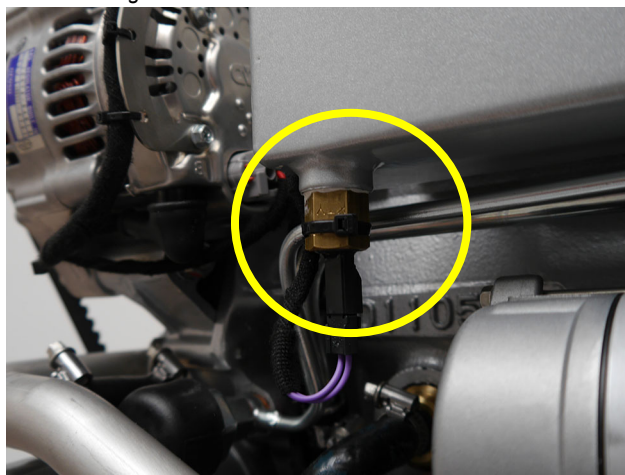

### Thermo-switch in the generator coil

1. Generator coil
2. Thermo-sensor
3. Housing

For the protection of the generator coil there are two thermo-switches inside the coil, which are for inserted parallel and safety's sake independently from each other.

Fig. 4.3.5-3: Coil thermo-switch

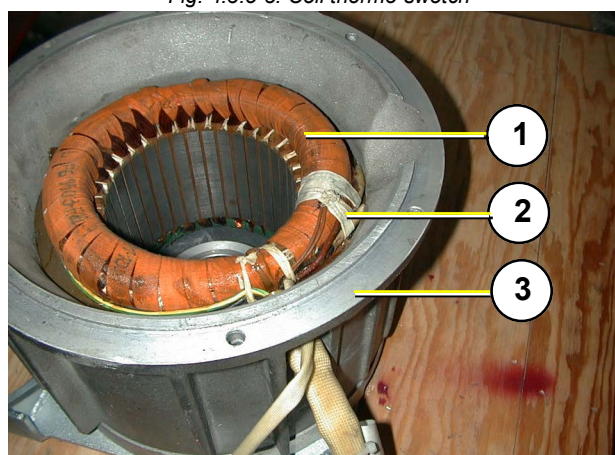



## Oil pressure switch

In order to be able to monitor the lubricating oil system, an oil pressure switch is built into the system. The oil pressure switch is on the back of the engine (before the electrical starter).

*Fig. 4.3.5-4: Oil pressure switch*

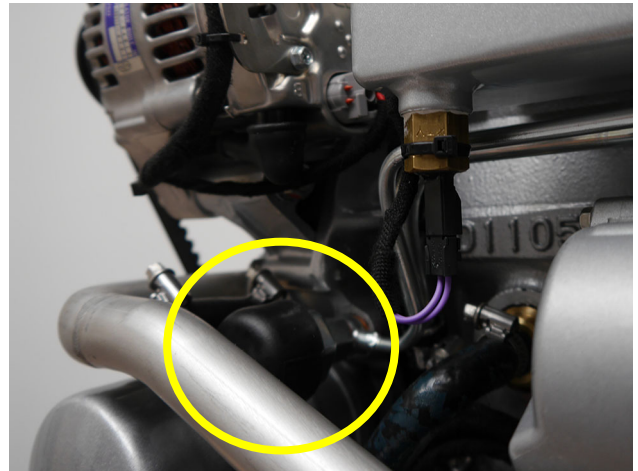



### 4.3.6 The oil circuit - Schema

Fig. 4.3.6-1: The oil circuit - Schema

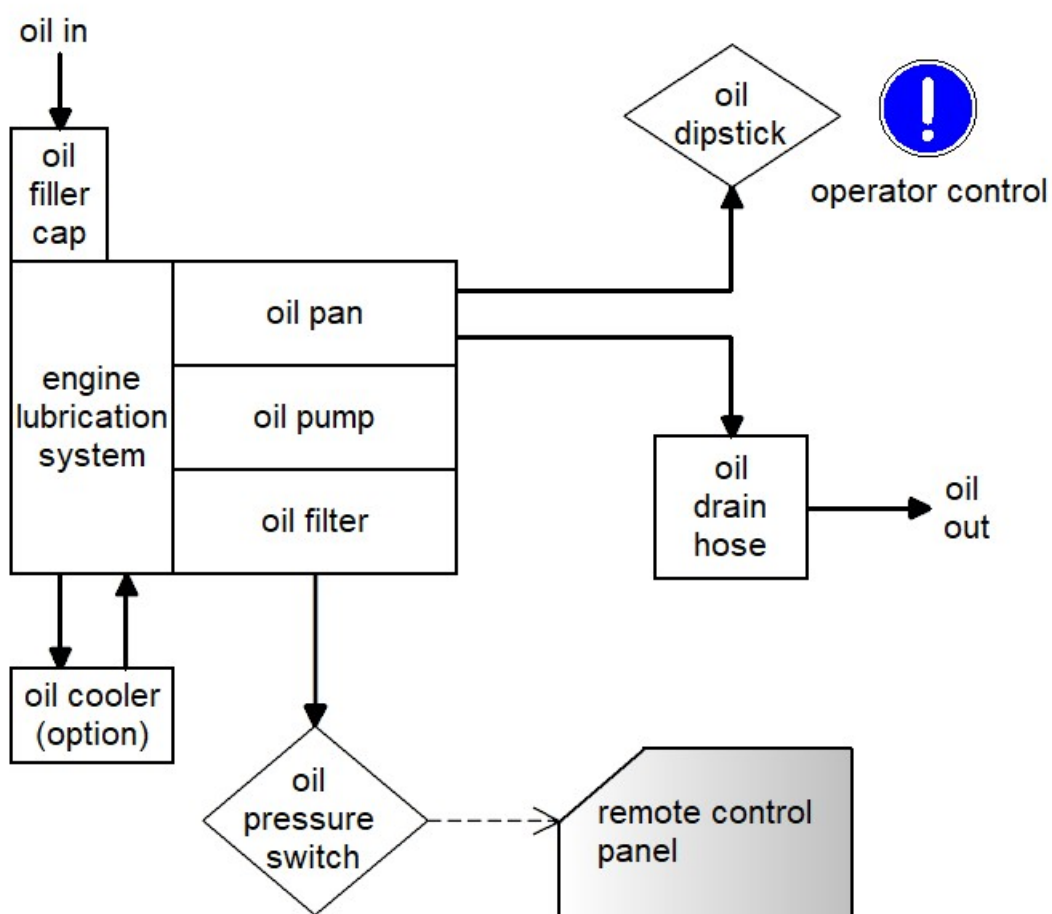



Leere Seite / Intentionally blank



## 5. Installation Instructions

**All connections (hoses, wires etc) and installation instructions are designed and suited for “standard” installation situations.**

**Attention!**



In situations where Fischer Panda has no detailed information concerning certain installation requirements (such as vehicle specifications, maximum vehicle speed -and all other conditions concerning special operating situations) the installation instructions should be used as an example guide only.

The installation must be undertaken and proved by a suitable qualified/trained person and may in accordance with the law as required by the country and special situation.

Damages caused by faulty or incorrect installation are not covered by the warranty.

### 5.1 Personal requirements

---

The described installation must be done by a technical trained person or a Fischer Panda service point.

#### 5.1.1 Hazard notes for the installation

---

see “**Safety Instructions - Safety First!**” on page 18.

**Notice!**

*Follow the general safety instruction at the front of this manual.*



**Danger for life! Working at a running generator can result in severe personal injury.**

**Danger! Automatic start-up**

The generator can be equipped with a automatic start device. This means, an external signal may trigger an automatic start-up. To avoid an unexpected starting of the generator, the starter battery must be disconnected before working at the generator.



**Improper installation can result in severe personal injuries or material damage.**

**Warning! Risk of injury**

- Always undertake installation work when the generator is switched off.
- Ensure there is sufficient installation clearance before start working.
- Ensure tidiness and cleanliness at the workplace. Loose components and tools lying around or on top of each other are sources of accidents.
- Only perform installation work using commercially available tools and special tools. incorrect or damaged tools can result injuries.





**Oil and fuel vapours can ignite on contact with ignition sources. Therefore:**

- No open flames during work on the generator.
- Do not smoke.
- Remove oil and fuel residues from the generator and floor.

**Contact with engine oil, antifreeze and fuel can result in damage to health. Therefore:**

- Avoid skin contact with engine oil, fuel and antifreeze.
- Remove oil and fuel splashes and antifreeze from the skin immediately.
- Do not inhale oil and fuel vapours.

**Danger for Life. Improper handling, operation, installation and maintenance can result in severe personal injury and/or material damage.**

*Electrical voltages above 48 volts (battery chargers greater than 36 volts) are always dangerous to life). The rules of the respective regional authority must be adhered to. Only an electrician may carry out installation of the electrical connections for safety reasons.*

**Generator, oil and antifreeze can be hot during/after operation. Risk of severe burns.**

**Batteries contain diluted sulphuric acids and bases**

Incorrect use can warm up and burst the batteries. Diluted sulphuric acid / base can escape. Under unfavourable conditions there is a risk of explosion

*Observe the instructions from your battery manufacturer.*

**During Installation/maintenance personal protective equipment is required to minimize the health hazards.**

- Protective clothing
- safety boots
- protective gloves
- Ear defender
- safety glasses

**Disconnect all load during the work at the generator to avoid damages at the load.**

**Warning! Danger of fire**



**Danger! Danger of poisoning**



**Attention! Danger to Life - High voltage**



**Warning! Hot surface/material**



**Warning!**



**Instruction! Personal protective equipment necessary.**

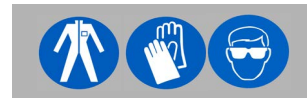

**Attention! Disconnect all load**





## 5.2 Environmental protection

---

---

**National exhaust emission regulations must be verified with engine specification.**

**Environmental protection!**

**Engine liquids/batteries are harmful for the environment.**



Collect discharged engine liquids and dispose it properly.

Batteries should be disposed properly.



---

## 5.3 Placement

---

### 5.3.1 General instructions

---

- It is important to pay attention to the fresh air intake.
- Sufficient space must be available below/next to the generator, in order to allow flow of cooling air. (Underside and side: Underneath is not sufficient!)
- The radiator may not be covered.
- Untrained personnel should never open the generator.

### 5.3.2 Preparing the base - Placement

---

Since Panda generators have extremely compact dimensions, they can be installed in tight locations. Attempts are sometimes made to install them in almost inaccessible places. Please consider that even almost maintenance-free machinery must still remain accessible at least at the front (drive belt, water pump) and the service-side (actuator, dipstick). Please also note that in spite of the automatic oil-pressure sensor it is still essential that the oil level has to be checked regularly.

The generator should not be placed in the proximity of light walls or floors, which can have resonance vibrations because of airborne sounds. If this should be unavoidable, then it is recommended that this surface is lined with heavy sheet material., which will change the mass and the vibration behaviour.

You should avoid fixing the generator on a slippery surface with little mass (i.e.). This acts as an amplifier of airborne sounds in the most unreasonable case. An improvement can be achieved by reinforcing these surfaces with ribs. In addition, the breakthroughs, which interrupt these surfaces, should be sawed off. The lining of the surrounding walls with a heavy layer (i.e heavy sheet material) and foam additionally improve the conditions.

The generator sucks its air from the surrounding engine room. Therefore it must be ensured that sufficient ventilation openings are present, so that the generator cannot overheat.

The Power out of the generator based on the following data:

Ambient temperature: 20 °C

Air pressure: 1000 mbar (100 m above normal Zero)

Rel. áir moisture: 30 % reg. the ambient temperature

Fuel temperature: up to 20 °C

Any differents to this data, for example an ambient temperature of 40 °C because of the build inside a maschine room/vehicle with a bad ventilation, will cause in a lower Power out (Derating).

### 5.3.3 Advice for optimal sound insulation

---

The convenient base consists of a stable framework, on which the generator is fastened by means of shockmounts. The combustion air can be sucked in unhindered.

Fischer Panda recommend captive shock mount!

#### Shock mount

*representative picture*

Fig. 5.3.3-1: Shock mount



#### Captive shock mount

*representative picture*

Fig. 5.3.3-2: Captive shock mount





## 5.4 Air suction filter as a source of noise

The external suction filter (not included on delivery) must always be used if the generator is to be used in a dust-free environment. This filter is connected by means of a hose with a connecting piece to the generator housing. The filter can be the source of considerable noise. If this is the case, an air intake muffler with the appropriate nominal width should be ordered from Fischer Panda. This is a cylinder, which takes up relatively large amount of room (Total length approx 700mm, Diameter 100mm).

## 5.5 Generator Connections

The position of the connections can differ, depending on the generator type. The appropriate cables and connections are described at the generator.

**The electrical connections MUST be carried out according to the respective valid regulations. This also concerns used cable materials. The cable supplied is meant for laying „protected“ (i.e. in pipe) at a temperature up to a max of 70 ° C (160 ° F). The on-board circuit must also be fitted with all essential fuses.**

Fig. 5.5.0-1: Connection scheme

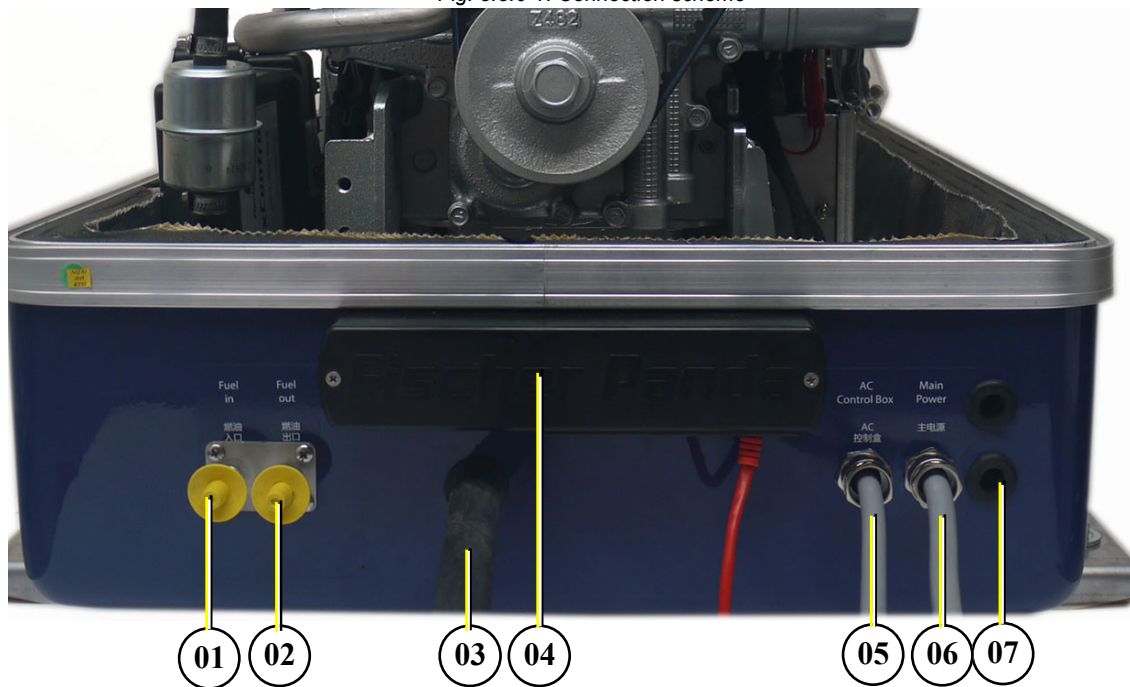

- 01. Connection fuel IN
- 02. Connection fuel OUT
- 03. Oil drain hose
- 04. xControl/fpControl connection panel

- 05. Cable for AC-Control box (not all models)
- 06. Load
- 07. Passage for starter battery cable positive (+) and negativ (-)

## 5.6 Fuel system installation

### 5.6.1 The following items need to be installed:

- Fuel supply pump (DC)
- Pre-filter with water separator (not part of the delivery)
- Fine particle fuel filter



- Non return valve (not part of the delivery)
- Return fuel line to fuel tank (unpressurized)

The external Fuel pump should be installed near the tank.

### Electrical fuel pump

With the Fischer Panda generator is usually supplied an external, electrical fuel pump (DC). The fuel pump must be installed close at the fuel tank. The electrical connections is prepared at the generator.

Fig. 5.6.1-1: electrical fuel pump



Fig. 5.6.1-2: Fuel system - scheme

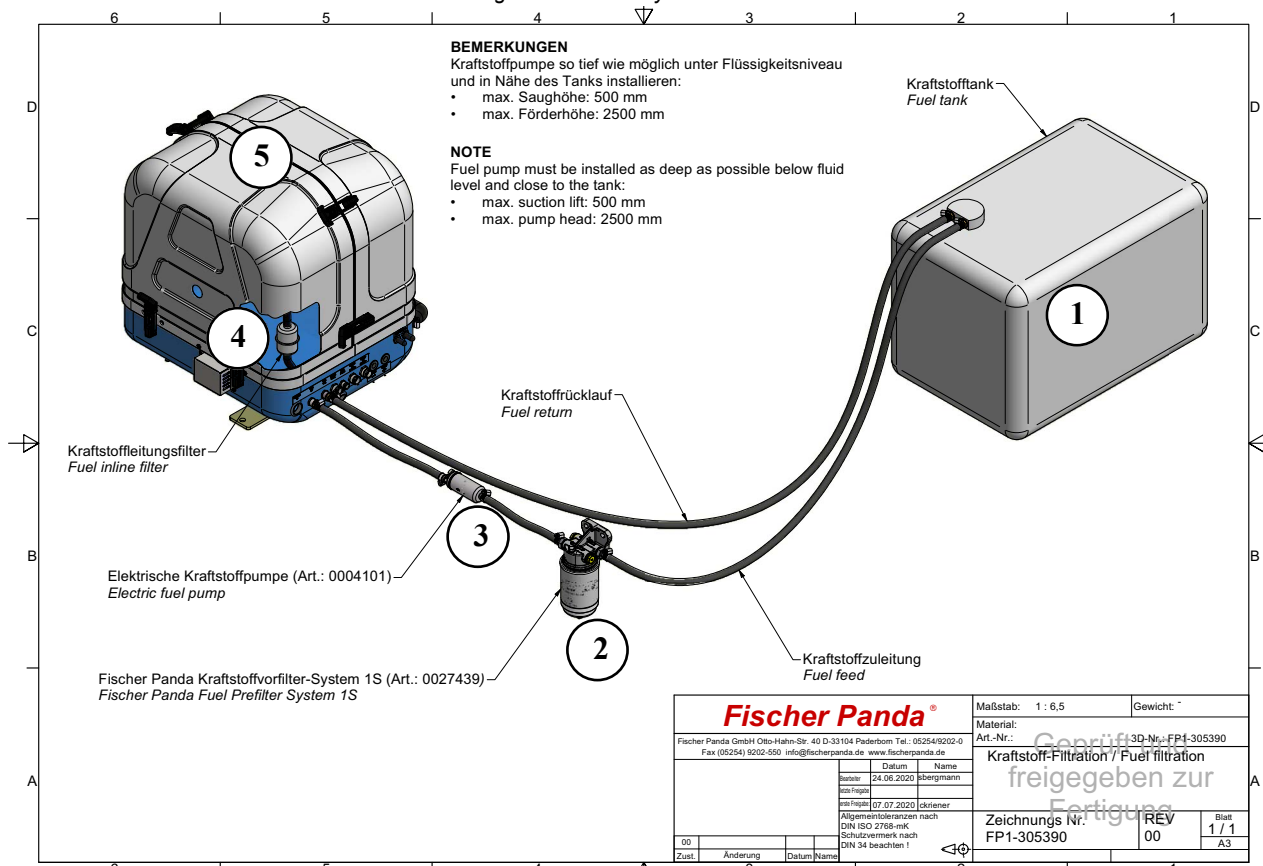

1. Fuel tank
2. external fuel prefilter with water separator
3. external fuel pump
4. Fuel inline filter
5. Generator

### 5.6.2 Connection of the fuel lines at the tank

General fuel feed and return line must be connected to the tank at separate connection points.

**Note:**



#### Connection of the return pipe to the tank

The return pipe connected to the tank must be dropped to the same depth as the suction pipe, if the generator is



mounted higher than the tank, in order to prevent fuel running back into the tank after the motor has been switched off, which can lead to enormous problems, if the generator is switched off for a long period.

### Non-return valve in the suction pipe

A non-return valve must be fitted to the suction pipe, which prevents the fuel flowing back after the generator has been switched off, if it is not possible to use the return flow pipe as a submerge pipe placed in the tank. The instructions „Bleeding Air from the Fuel System“ must be read after initial operation or after it has stood still for a long period, in order to preserve the starter battery.

### Non-return valve for the fuel return pipe

**If the fuel tank should be installed over the level of the generator (e.g. daily tank), then a non-return valve must be installed into the fuel return pipe to guarantee that through the return pipe no fuel is led into the injection pump.**

**Attention!**



## 5.6.3 Position of the pre-filter with water separator

**Additionally to the standard fine filter a pre-filter with water separator must be installed outside of the sound insulation capsule in the fuel system line (not included in the delivery).**

*Fig. 5.6.3-1: Fischer panda fuel pre-filter S1 with water separator*



## 5.7 Ventilating the Fuel System

Normally, the fuel system is designed to ventilate air itself i.e. as soon as the electric starter motor starts operation the fuel pump starts working and the fuel system will be de-aerated after some time automatically. It is nevertheless essential to ventilate the system as follows prior to the first operation (as all hoses are empty):

1. Press switch „ON“. All functional elements must light up.
2. Press failure bypass switch and keep firmly pressed. The electrical fuel pump must be audible. Switching on and off the solenoid valve at the generator will be audible by pressing the failure bypass switch (if capsule removed). Pressing the failure bypass switch for approx 3 - 4 minutes will loosen the ventilation screw located at the fuel solenoid valve. The button must continue to be pressed, whilst opening the screw. A large cloth or Kleenex tissue must be laid beneath the connection to prevent escaping fuel running into the capsule. If the fuel runs out without air bubbles, then the ventilation screw can be closed. Only then may the button be released.
3. Pressing the starter button can now start the machine. The machine should start after a short period. If this does not occur, then a connecting nut fitted to the injection line must be loosened and starting procedure repeated. Retighten the washers after successfully starting!

## Ventilation screw at the fuel solenoid valve

Not all generator models are equipped with a fuel solenoid valve. At generators without a fuel solenoid valve, a single ventilation screw is installed.

Sample picture

Fig. 5.7.0-1: Ventilation screw at the fuel solenoid valve

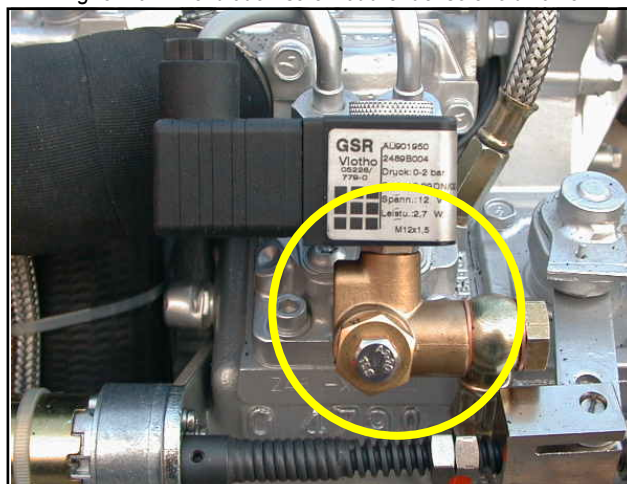

## 5.8 Installation of the cooling system

### 5.8.1 The cooling system / general instructions

The Fischer Panda vehicle generator is delivered without a radiator, with the exception of generators with permanently installed radiators such as the PVK-UK or the PSC series.

Depending on the purpose and installation situation, a wide variety of Fischer Panda radiators are available for the optimum customization of the system. Operation with a commercially available vehicle radiator is possible. The corresponding dimensioning must be implemented by the installer.

**For generators with a permanently installed radiator (e.g. Note: PVK-UK series), the radiator dimensioning and the installation are not necessary.**



## 5.9 Radiator baseplate

The radiator baseplate shall be dimensioned in accordance with the purpose. The corresponding checks and entries in the vehicle papers shall be implemented by the operator.

### 5.9.1 Determining the size of the radiator

The size of the radiator must be dimensioned in accordance with the total thermal load, the operating conditions, and the installation situation.

**In principle, the thermal load of the generator equals 1.8 times the electrical rated power (1.8 times with a water-cooled silencer, 1.2 times with a dry silencer) in kW. This means that e.g. a Panda 12000 PVMV-N generator with a rated power of 10 kW has a thermal load of 18 kW.**

Note:



**The radiator must always be dimensioned taking into account a safety margin adjusted for the operating conditions. Undersized radiators will result in an emergency shut-down. This may damage other equipment that is connected to them.**

**Warning: Include safety margin in the calculation.**





---

## 5.9.2 Radiator design

---

The radiator consists in 3 main components:

1. Radiator. Depending on the version, includes an integrated expansion tank or an external expansion tank.
2. Fan. Depending on the generator, as a DC fan (e.g. 12 V-24 V) or as an AC fan (e.g. 230 V 50 Hz) with respective input voltage.
3. Cover (optional).

## 5.9.3 Radiator types

---

In principle, the following radiator types are differentiated.

1. Flange-mounted radiator for installation on top of, on the side of, or under the vehicle - see "Installation location for radiators for roof, side, or underfloor mounting on the vehicle" on page 57.
2. Built-in radiator for installation in the vehicle wall or cabin wall - see "Installation location for radiator in the vehicle wall or cabin wall" on page 61.
3. Permanently installed radiators for the PVK-UK series
4. Permanently installed radiators for the PSC series for operation inside containers or for tunnel installation - see "Installation location for radiator in a tunnel" on page 62.

The radiator must be installed away from the generator in a well ventilated area. In doing so, it must be ensured that the air outflow of the radiator is completely uninhibited. Turbulence and thermal short-circuiting must be avoided.

The radiator can be installed in a vertical or a horizontal position. It must be taken into account that the air intake is located above the fan motor.

The best results will be achieved if the radiator can be mounted horizontally on the vehicle roof.

### 5.9.3.1 Installation location for radiators for roof, side, or underfloor mounting on the vehicle

Fig. 5.9.3-1: Radiator installation - example

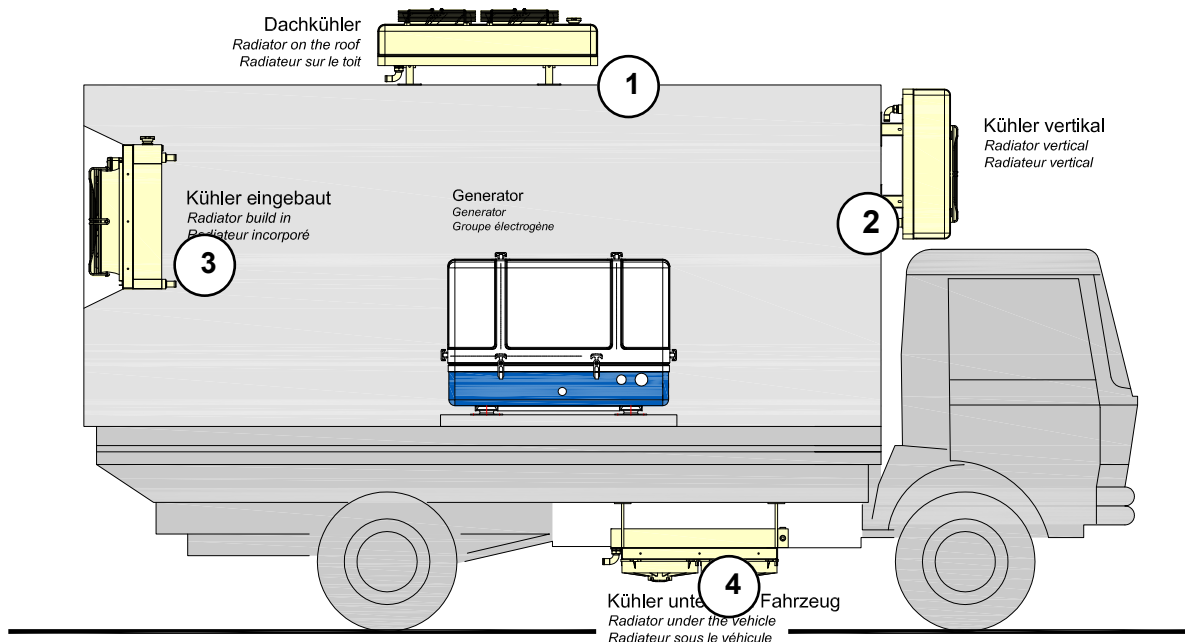

### Panda PVMV-N

mögl. Positionen des externen Kühlers

Possible positioning of the external radiator

Positions possibles de radiateurs externes

WG.1087e00

**Fischer Panda**  
 Otto-Hahn-Str. 32-34 D-33104 Paderborn Tel.: (05254) 9202-0  
 Fax (05254) 9202-92 info@fischerpanda.de www.fischerpanda.de

- |  |   |
|--|---|
| 1. Radiator mounted on the roof          | 3. Radiator build into the vehicle wall |
| 2. Radiator mounted in vertical position | 4. Radiator mounted under the vehicle   |

Fig. 5.9.3.1-2: Radiator dimensions

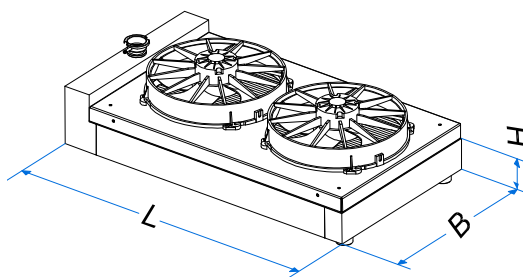

### 5.9.3.2 Roof installation

**Please note:**

- Minimum distance to vehicle roof: 100 mm.
- Minimum distance to next vertical wall: 1/2 radiator width.
- Min. distance to gas exhaust (heat and dirt source): 500 mm.
- The max. permissible vehicle height must not be exceeded.
- Install warnings stating new vehicle height inside driver's cab.
- During operation, the exhaust flow must be uninhibited for at least 3 meters.



Fig. 5.9.3.2-1: Schematic: radiator, roof installation

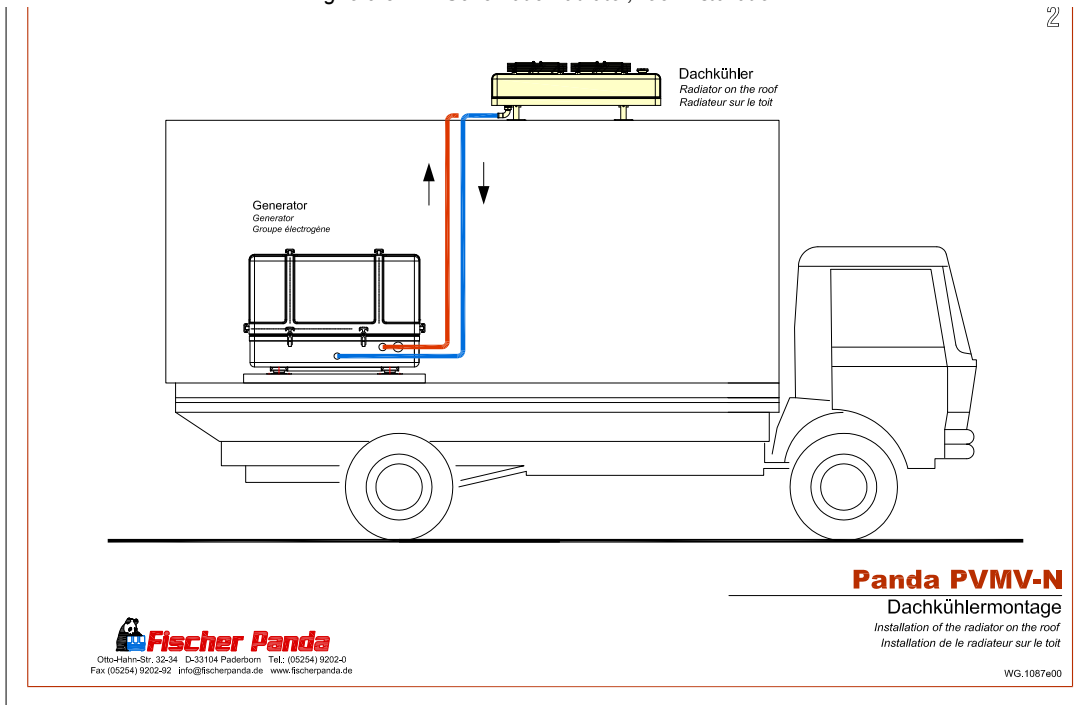
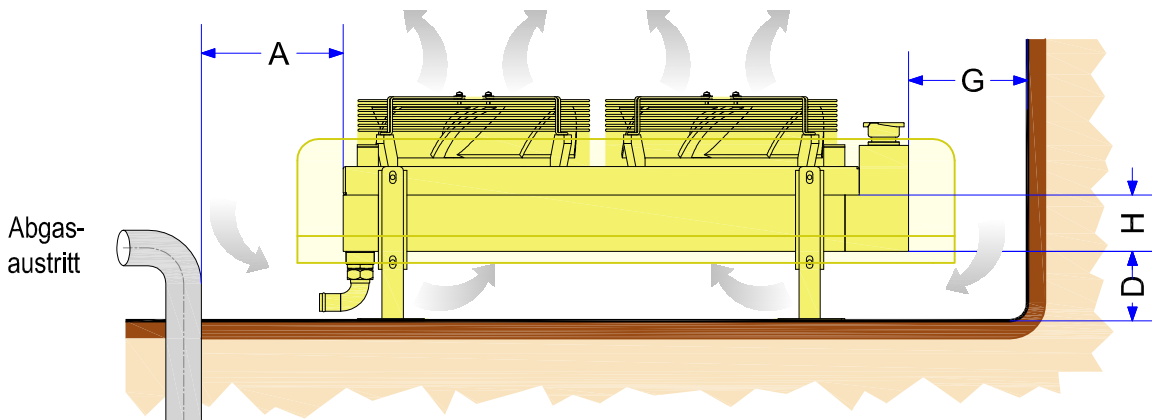

Fig. 5.9.3.2-2: Schematic: radiator, roof installation

**Dachkühler**  
Radiator on the roof  
Radiateur sur le toit

A = mind. 500 mm  
D = mind. 100 mm  
G = mind. 1/2 B  
Freies Abblasen muß gewährleistet sein



### 5.9.3.3 Installation on the vehicle wall

**Please note:**

- Minimum distance to vehicle wall: 100 mm.
- Min. distance to gas exhaust (heat and dirt source): 500 mm.
- The max. permissible vehicle length or width must not be exceeded.
- During operation, the exhaust flow must be uninhibited for at least 3 meters.

Fig. 5.9.3.3-1: Schematic: radiator, vehicle wall installation

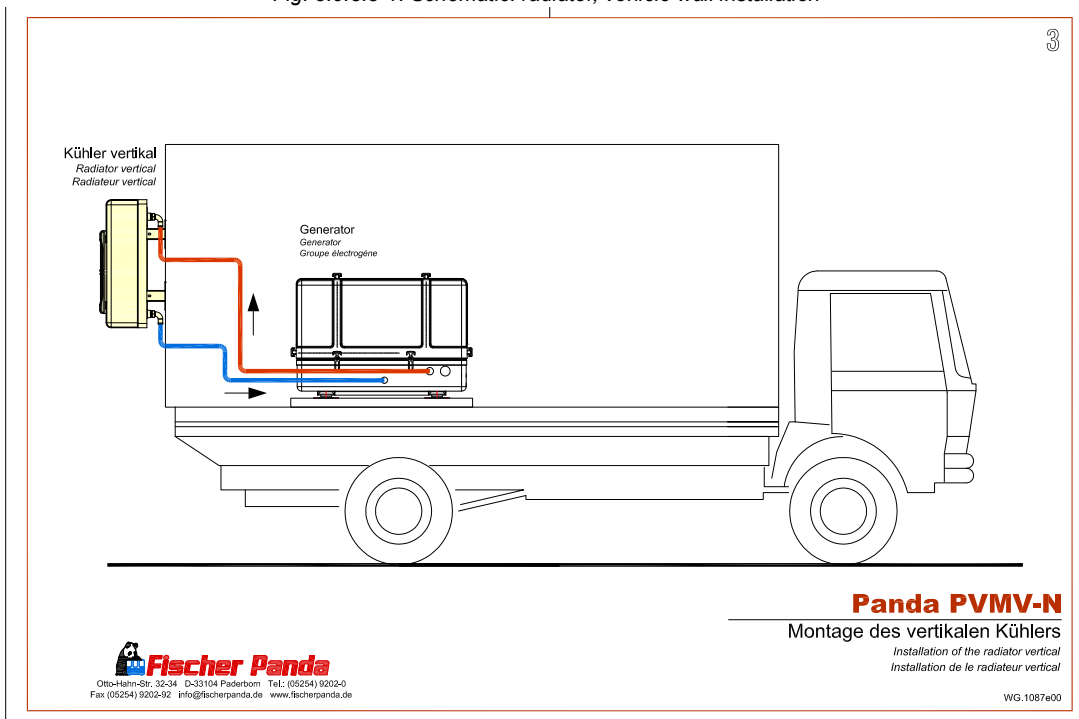
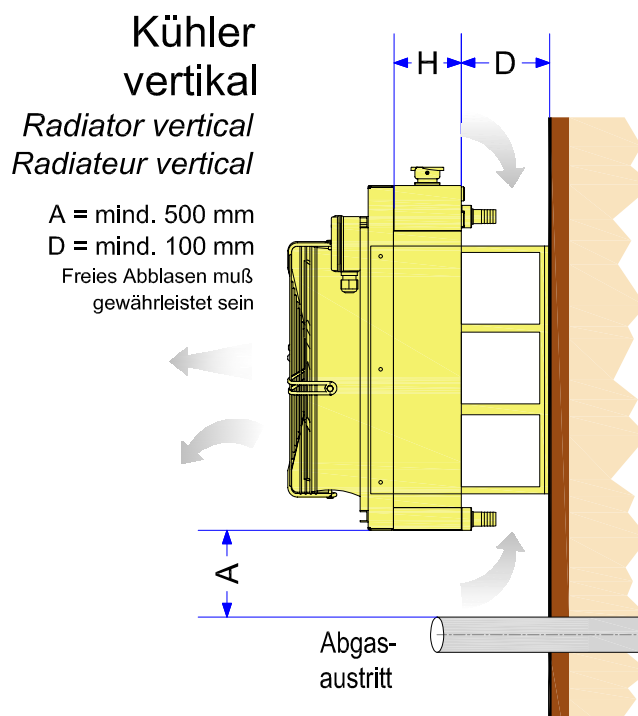

Fig. 5.9.3.3-2: Schematic: radiator, vehicle wall installation





### 5.9.3.4 Underfloor installation of radiator

**Please note:**

- Minimum distance to vehicle floor: 100 mm.
- Minimum distance to ground: 1/2 radiator width
- Min. distance to gas exhaust (heat and dirt source): 500 mm.
- The max. permissible vehicle height must not be exceeded.

Fischer Panda does not recommend underfloor installation. The radiator can quickly become dirty. Rock impacts can result in damage to the radiator. The efficiency of the radiator will drop due to thermal short-circuiting. The radiator may have to be dimensioned larger to compensate.

**Note:**



The installation position of the radiator (upside down or not) depends on the airflow direction of the fan. The airflow must be always from the vehicle side through the radiator to the ground.

**Attention:**



Fig. 5.9.3.4-1: Underfloor installation of radiator

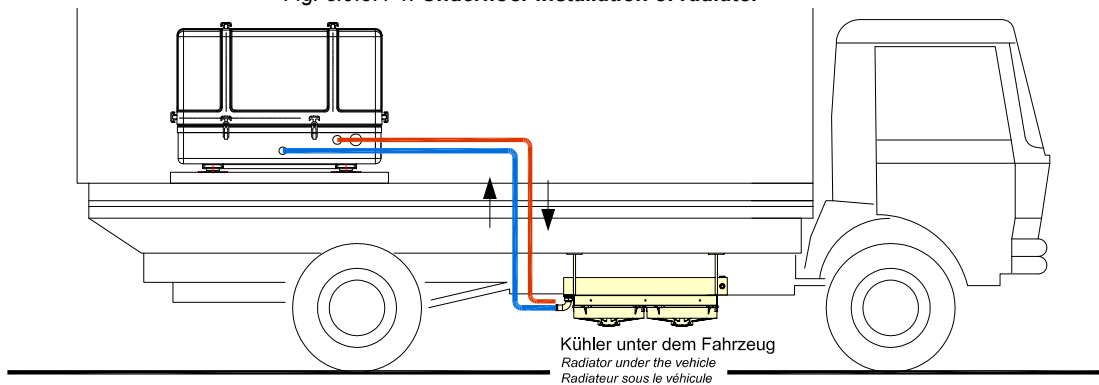

### Panda PVMV-N

#### Montage des Kühlers unter dem Fahrzeug

Installation of the radiator under the vehicle  
Installation de le radiateur sous le véhicule

**Fischer Panda**  
Olte-Hattin-Str. 32-34 D-33104 Paderborn Tel.: (05254) 9202-0  
Fax (05254) 9202-92 Info@fischerpanda.de www.fischerpanda.de

WG.1087e00

Fig. 5.9.3.4-2: Underfloor installation of radiator

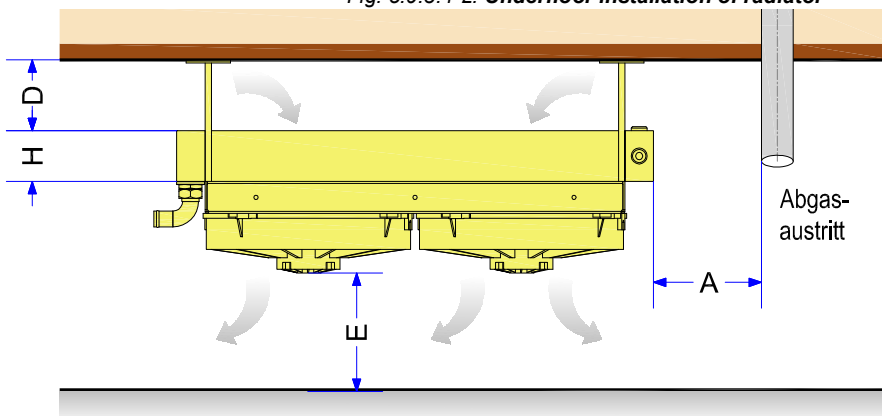

**Kühler unter dem Fahrzeug**  
*Radiator under the vehicle*  
*Radiateur sous le véhicule*

Von FP nicht empfohlen wegen Verschmutzung, Steinschlag und Effektivität (thermischer Kurzschluss) Kühler muß evtl. größer ausgelegt werden.

A = mind. 500 mm  
D = mind. 100 mm (abhängig von L x B)  
E = mind. 1/2 B  
Freies Abblasen muß gewährleistet sein

### 5.9.3.5 Installation location for radiator in the vehicle wall or cabin wall

A cabin installation is achieved if the set-up location is freely accessible during operation and serves as a working space, if applicable.

**Please note:**

- If persons are present in the set-up space during operation, a safety circuit must ensure that the air intake is opened.

**Incorrect installation in the cabin**

- Air intake too narrow
- Generator air intake too close to the wall
- Hot air can be taken in next to the radiator
- Exhaust gas line not insulated, heats up combustion air

Fig. 5.9.3.5-1: Incorrect installation in the cabin

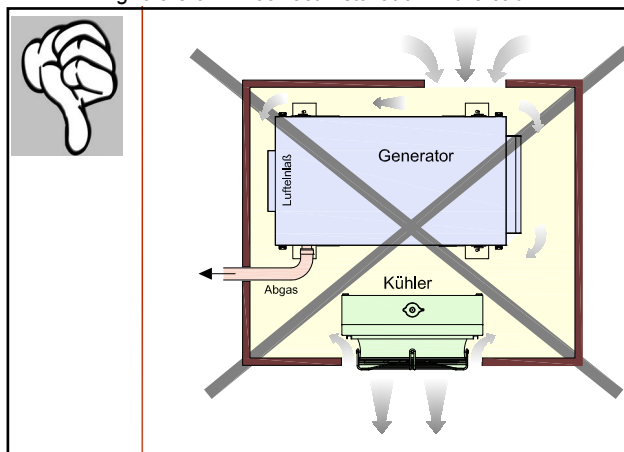

**Correct installation in the cabin**

- Air intake is min. radiator size (safety grating and decorative grille must be taken into account)
- Uninhibited air intake for generator
- Exhaust flow direction of radiator is shielded and air exhaust enlarged (safety grating and decorative grille were taken into account)
- Exhaust line insulated

Fig. 5.9.3.5-2: Correct installation in the cabin

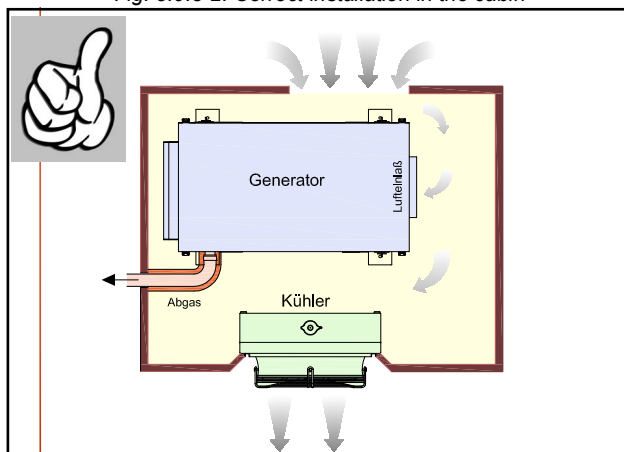



### 5.9.3.6 Installation location for radiator in a tunnel

A tunnel installation is implemented if the set-up location is separated from the vehicle cab by constructive measures.

#### Please note:

- The total of the air intakes must be at least equal to the radiator width (
- The total of the cross-sections of the air ducts incl. lateral air intake must be at least equal to the radiator width
- The distance between generator and radiator must equal at least 1/2 the radiator width
- Lateral air supply between generator and radiator can be designed on the side, above, or below

#### Incorrect installation in a tunnel

- Air intake too narrow
- Generator air intake too close to the wall
- Hot air can be taken in next to the radiator
- Exhaust gas line not insulated, heats up combustion air

Fig. 5.9.3.6-1: Incorrect installation in a tunnel

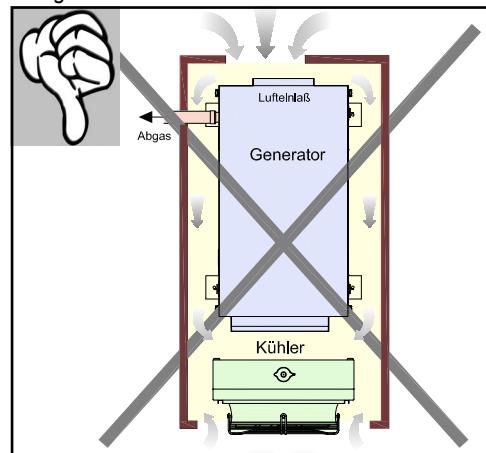

#### Correct installation in a tunnel

- Air intake (C) is min. radiator size (B) (safety grating and decorative grille must be taken into account)
- Total of air intakes (A) equals min. the radiator size (B)
- Uninhibited air intake for generator
- Exhaust flow direction of radiator is shielded and air exhaust enlarged (safety grating and decorative grille were taken into account)
- Exhaust line insulated

Fig. 5.9.3.2: Correct installation in a tunnel

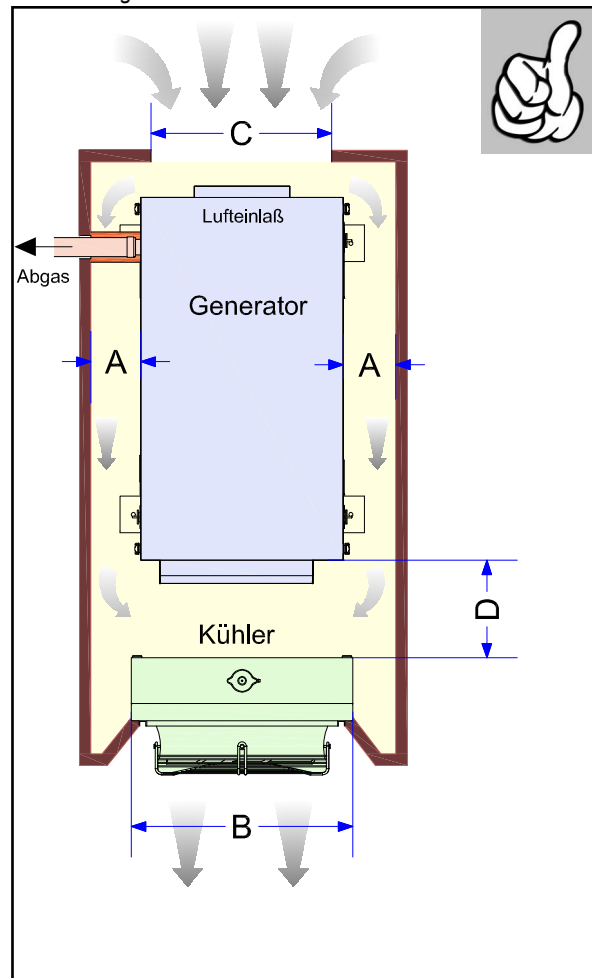

### 5.9.3.7 Installation location for generators of the PVK-UK series

Generators of the PVK-UK series are designed for lateral installation on the vehicle chassis

**Please note:**

- Min. distance between radiator and vehicle chassis must be  $1/2 B$ .
- Min. distance to gas exhaust (heat and dirt source): 500 mm.
- The exhaust flow area must be unobstructed. No impairment to the vehicle chassis or installations.

Fig. 5.9.3.7-1: PVK-UK installation location

Ansicht von oben

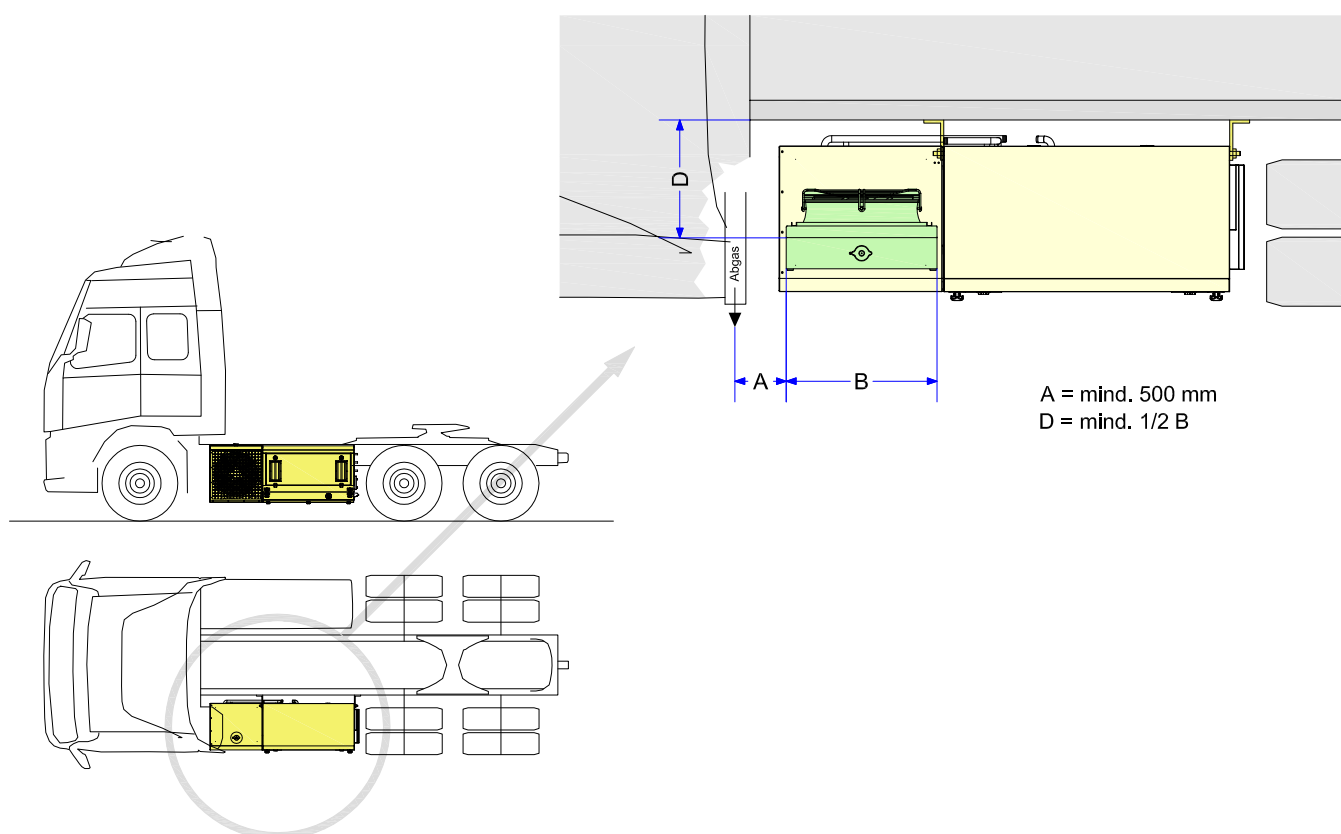

### 5.9.4 Coolant hoses

- The diameter of the coolant hoses must be equal to or greater than the diameter of the generator connections.
- A vacuum-tight and temperature resistant hose (min. 120 °C) must be used.
- The hoses must be pressure resistant under vacuum conditions.
- Depending on the application location, the hoses must be UV resistant.
- The hoses must be weather resistant and chemical resistant (resistant to oil, etc.).
- The bending radii of the hose type shall be taken into account.
- The hoses must have a general operating permit (ABE) / approval certificate.

### 5.9.5 Connection of the external radiator

See section 5.11, "Installation schematics," on page 67.



## 5.9.6 Coolant expansion tank

---

### Coolant expansion tank for systems with a radiator below the generator.

For operation, a coolant expansion tank must be installed at least 100 mm above the level of the exhaust manifold and the radiator.

The ventilation line of the radiator and the generator shall be installed on the top connection. The bottom connection is used to refill the coolant circuit and is integrated in the coolant circuit at a low-lying location using a T-fitting.

The coolant expansion tank can be procured from the Fischer Panda accessories.

### Coolant expansion tank for systems with a radiator installed above the generator.

If the radiator is installed min. 100 mm above the exhaust manifold, a radiator with integrated coolant expansion tank can be used. In this case, the ventilation line of the generator is connected to the return line to the radiator (hot side) using a T-fitting. It is refilled via the feed line (cold side) to the generator.

## 5.9.7 Installation of a coolant temperature indicator

---

Where sensitive systems are installed (e.g. in television transmission vehicles, rescue vehicles, or other vehicles with sensitive metrological installations) a remote indicator for coolant temperatures should be installed. It is, however, highly recommended to install two indicator instruments:

1. coolant feed line (cold side)
2. coolant return line (hot side)

The exact location of the measuring unit is not important, here.

Generators of the i-serie and x-serie can be monitored with the temperature displayed at the remote control panel. additional coolant temperature indicators are not necessary here.

**A corresponding indicator kit can be procured from Fischer Panda.**

**Note:**



For subsequent installation, Fischer Panda T-fittings are available for hose elements in which the temperature sensors are then installed.

## 5.9.8 Permissible coolant temperatures

---

- The radiator must be dimensioned such that the feed line to the generator (cold side) does not get hotter than 70 °C during normal operation. The coolant feed line must be connected to the coolant pump.
- The coolant volume flow must be dimensioned such that the temperature difference between engine inflow (coolant pump) and engine outflow (exhaust manifold) is no greater than 12 K under full load.

To ensure this, the coolant hoses shall be routed without kinks or sharp bends. Resistance, e.g. due to narrowed points in transition pieces or shut-off valves, shall be avoided.

**Note:**



## 5.9.9 Coolant pump

---

- The generator is equipped with a normally suctioning (not self-priming) coolant pump.
- The coolant pump is designed so that a max. distance of 5 m between pump and radiator is possible.



If the necessary coolant volume flow is not achieved (e.g. due to a special installation situation), an external coolant pump with the corresponding output must be installed in the coolant circuit to increase the coolant volume flow.

**Note:**



**The pressure in the coolant circuit must not exceed 0.7 bar!**

**Warning:**



**Required coolant volume flow:**

Fig. 5.9.9-1: Coolant volume flow

Generator type	Coolant volume flow
Panda 4500	min. approx. 10 L/min
Panda 8000 - 10000	approx. 16 to 22 L/min
Panda 12000 - 15000	approx. 24 to 28 L/min
Panda 18 - 24	approx. 32 to 38 L/min
Panda 30 - 32	approx. 40 to 45 L/min
Panda 42 - 65	approx. 50 to 60 L/min

## 5.9.10 Radiator fan

Radiator fans are wearing parts. To ensure a long service life, there must be no objects impairing or blocking the free movement of the fan during operation. Such objects include:

- Snow
- Ice
- Leaves
- Branches
- Increased air resistance due to dirty radiator

## 5.9.11 Anti-freeze and corrosion protection

At the factory, the coolant is adjusted to a 50% concentration of G48 anti-freeze solution (approx. -40 °C). If lower temperatures are possible during transport or storage, the coolant filling must be drained or adjusted for the lower temperatures.

After draining the coolant, the system must be blown dry with compressed air at 0.5 bar. This will ensure that the system is complete drained.

The anti-freeze agent also serves to protect the system against corrosion. The anti-freeze concentration in the coolant must not drop below 30 %.

## 5.9.12 Logging the temperature values during initial start-up

It is mandatory to measure the temperature values of the circulating coolant in the circuit after installing the generator for the initial start up. Two remote thermometers must be used for this purpose. One connection must be mounted to the coolant feed line to the engine, the second one on the coolant outfeed. The generator must then be loaded with min. 75 % of the rated power after a brief warm-up phase. The circulation of the coolant must be checked. The values must fall within the following limits:

1. Coolant feed line max. 70 °C in permanent operation mode at maximum load
2. Coolant return line max. 85 °C in permanent operation



mode.

3. Differential of the two values: This item is of particular importance and provides information on the circulation of the coolant. The difference should be max. 17 K for a coolant water system with an integrated water-cooled muffler. It should, however, typically be between 10 and 12 K.

If the difference is greater than 15°K, the coolant circulation is not sufficient. The water circulation must then be increased. This can be solved by e.g. improving the line routing, or by reducing the belt pulley diameter. It is absolutely necessary to measure the output of the cooling system after installing the generator. The values given above shall be considered maximum permissible values. They apply to operation in increased temperatures, as well. In permanent operation mode at external temperatures around 20 °C, the values must fall near the lower limit of the tolerance.

**Each manual includes installation certificates, which must be filled in after installation and returned to the manufacturer (copy).**

**Note:**



**Returning the installation certificates and commissioning logs is an important component of the warranty conditions.**

## 5.10 Custom installations

---

The effects on the warranty must be agreed on a case-by-case basis with Fischer Panda.

### 5.10.1 External heat exchangers

---

External heat exchangers shall be installed as per the specifications of the respective manufacturers.

### 5.10.2 External engine pre-heater

---

The external engine pre-heater shall be installed as per the manufacturer's instructions.

This applies to:

- electrical pre-heater systems (e.g. Defa),
- diesel-operated pre-heater systems,
- petrol-operated pre-heater systems.

### 5.10.3 Keel cooling

---

The keel cooling system shall be dimensioned and installed as per the manufacturer's instructions.



## 5.11 Installation schematics

At generators with xControl, the ECU measures the coolant temperature at the exhaust manifold. The external temp switch sensor in the hydraulic lines is not necessary at these generators.

Note:



### 5.11.1 Installation for vertical radiator installation

Fig. 5.11.1-1: Vertical radiator - schematic

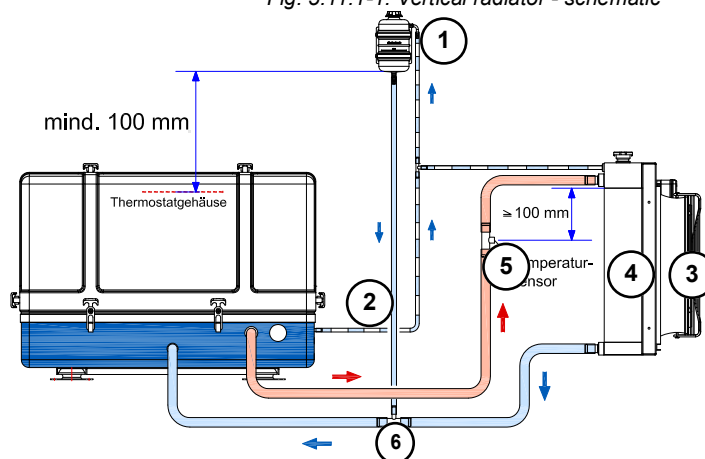

- 01. Coolant expansion tank
- 02. Engine bleed line
- 03. Fan for radiator

- 04. Radiator
- 05. T-fitting with connection for thermal switch/sensor for external fan control
- 06. T-fitting

### 5.11.2 Installation for mounting the radiator under the vehicle

Fig. 5.11.2-1: Underfloor radiator - schematic

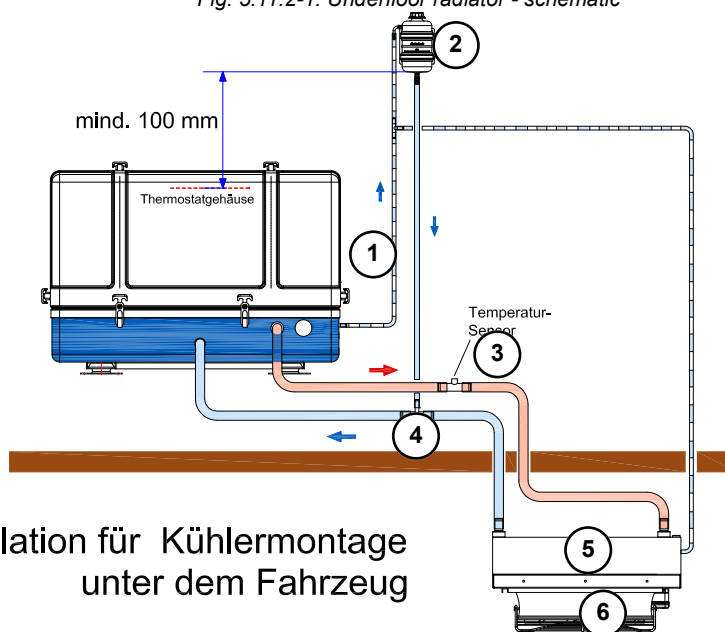

Installation für Kühlermontage  
unter dem Fahrzeug

- 01. Ventilation line
- 02. Coolant expansion tank
- 03. T-fitting with connection for thermal switch/sensor for external fan control

- 04. T-fitting
- 05. Radiator
- 06. Fan for radiator



### 5.11.3 Installation schematic for roof mounted radiator with expansion tank

Fig. 5.11.3-1: Roof-mounted radiator - schematic

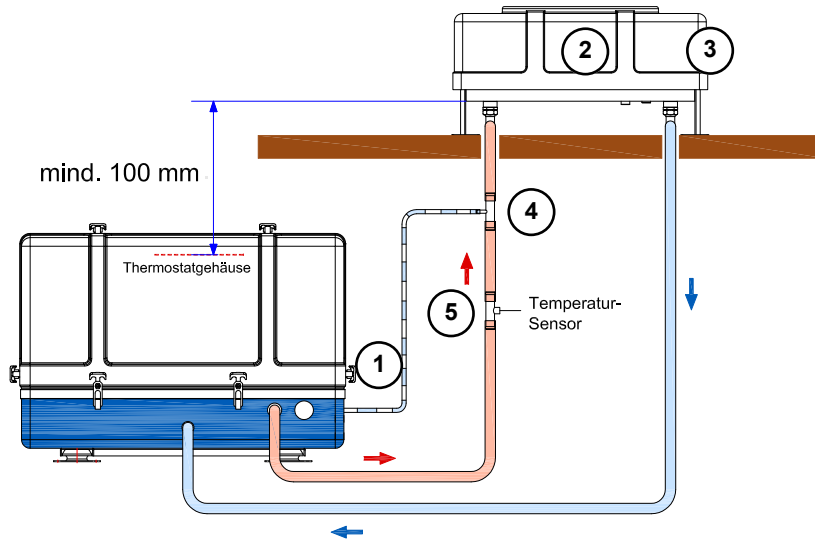

#### Installation für Dachkühlermontage mit integriertem Ausgleichsbehälter

- 1. Engine bleed line
- 2. Radiator (horizontal)
- 3. Coolant expansion tank (integrated)
- 4. T-fitting for bleed line
- 5. T-fitting with connection for thermal switch/sensor for external fan control

### 5.11.4 Installation radiator with intercooler - schematic sample vertical radiator

Fig. 5.11.4-1: Installation Radiator with Intercooler -Schematic sample vertical Radiator

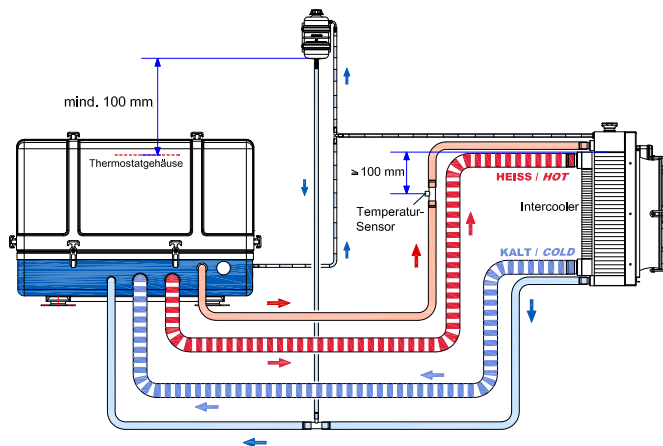

#### Installation für vertikale Kühlermontage mit Intercooler

**Panda PVMV-N**  
Kühlerinstallation

WG.1087600

The installation sample must be adapted to the Radiator/ Note:  
System.





## 5.12 Exhaust installation

### 5.12.1 Exhaust connection for roof outlet

Fig. 5.12.1-1: Exhaust installation - scheme

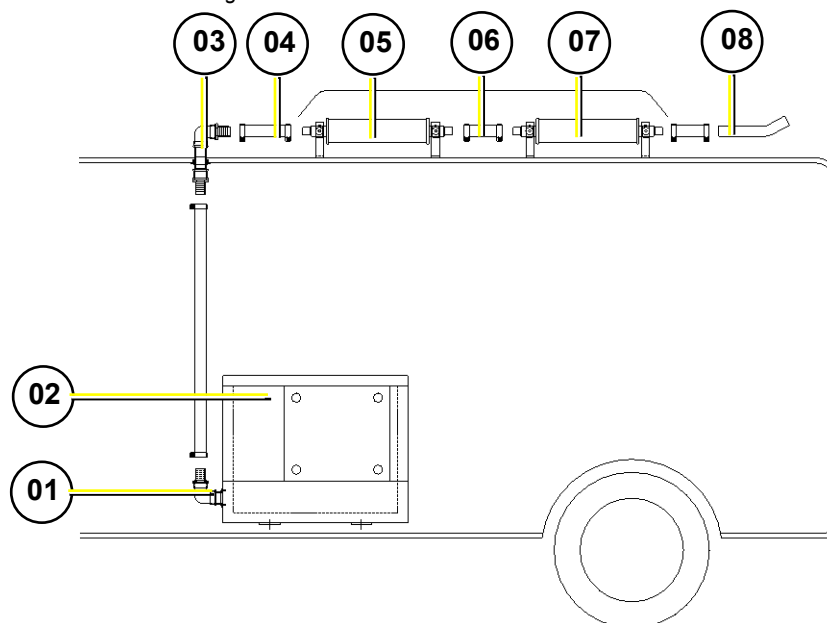

- |                               |                                       |
|-------------------------------|---------------------------------------|
| 01. Exhaust outlet            | 05. External pre-silencer (option)    |
| 02. Generator                 | 06. Exhaust pipe                      |
| 03. Roof through fitting      | 07. External series silencer (option) |
| 04. Vibration damper (option) | 08. End pipe                          |

### 5.12.2 Exhaust connection for mounting below the vehicle

Fig. 5.12.2-1: Exhaust installation - scheme

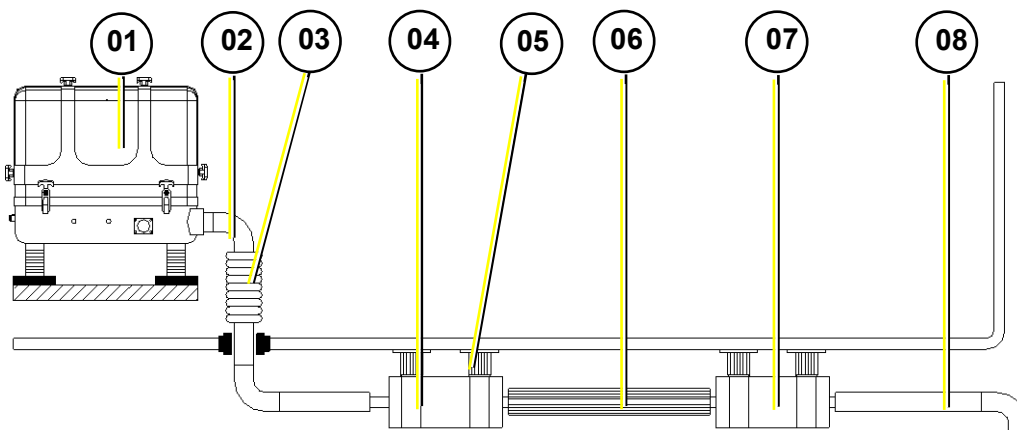

- |                                    |                                       |
|------------------------------------|---------------------------------------|
| 01. Generator                      | 05. Vibration damper                  |
| 02. Exhaust outlet                 | 06. Exhaust pipe                      |
| 03. Compensator (option)           | 07. External series silencer (option) |
| 04. External pre-silencer (option) | 08. End pipe                          |



## 5.13 Connection of the Electrical Components

Fig. 5.13-1: Electrical Connections - example

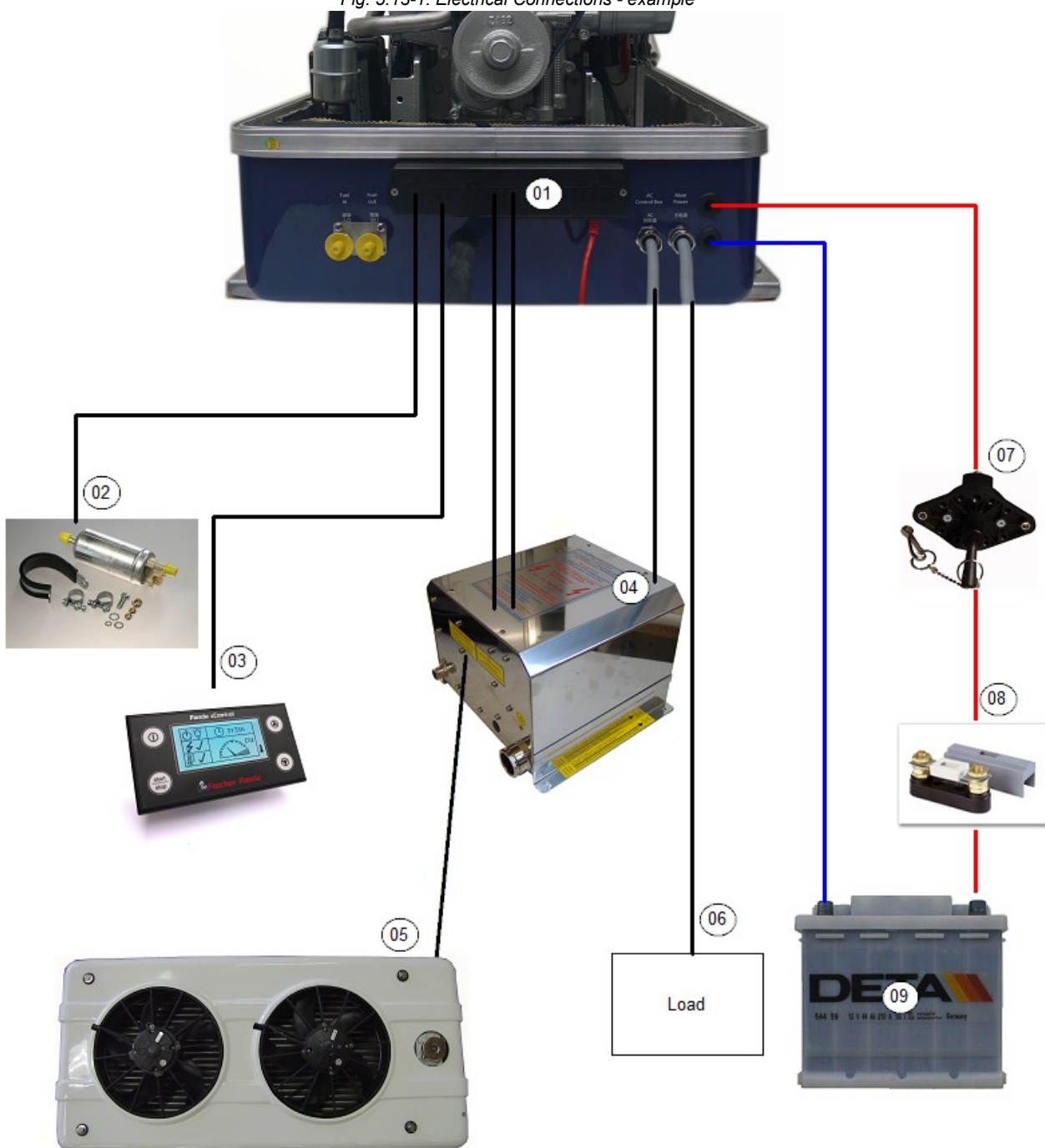

- 01. Generator
- 02. External fuel pump
- 03. Remote control panel
- 04. AC control box
- 05. Radiator with fan

- 06. Switchboard
- 07. Battery main switch
- 08. Battery fuse
- 09. Starter battery



## 5.14 Generator AC System Installation

Before the electrical system is installed, READ the SAFETY INSTRUCTIONS of this manual FIRST!

Be sure that all electrical installations (including all safety systems) comply with all required regulations of the regional authorities. This includes lightning conductor, personal protection switch etc.

Warning!: Electrical Voltage



### 5.14.1 3-phase Generator

For 3-phase generators (400 V systems) an additional 3-phase module is installed. This can be located in the generator capsule, on the generator or in the AC-box / control cabinet.

In the 3-phase module, the data of the individual phases are recorded and transferred to the controller. The display shows the data of each phase.

Fig. 5.14.1-1: 3-phase module at the Generator



### 5.14.2 AC-Control box

An AC-Control box is necessary for the operation of Panda generators. According to the generator capacity the AC Control box is variable dimensioned and equipped. It is supplied with a lockable cap.

This cap must necessarily be locked when the generator is running, as at all models during operation, 400 V is present in the AC control box.

For the excitation of the generator all necessary capacitors and the starting current limitation (not available at all models) are stored in the AC Control box. The AC Control box must be connected to the generator with the electrical lines (230 V and 400 V).

Only qualified personnel may carry out working at the AC Control box.

Danger to life - 400V AC





Fig. 5.14.2-1: AC-Control box single phase - example

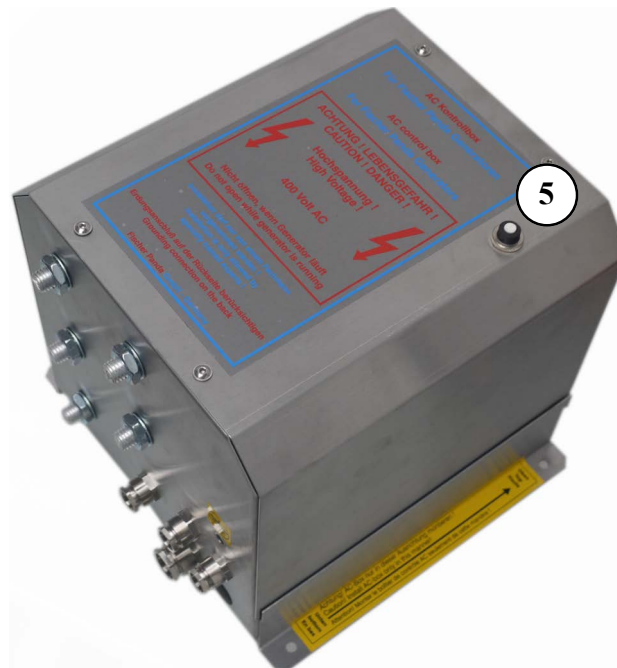

1. Terminal block for excitation
2. Solenoid for radiator fan
3. Boost solenoid

4. Capacitors
5. Fuse for radiator fan (single phase)

Fig. 5.14.2-2: AC-Control box three phase - example

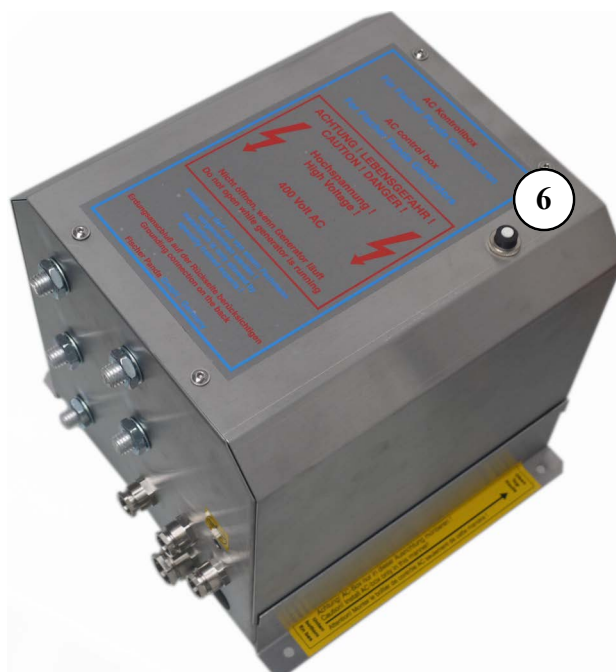
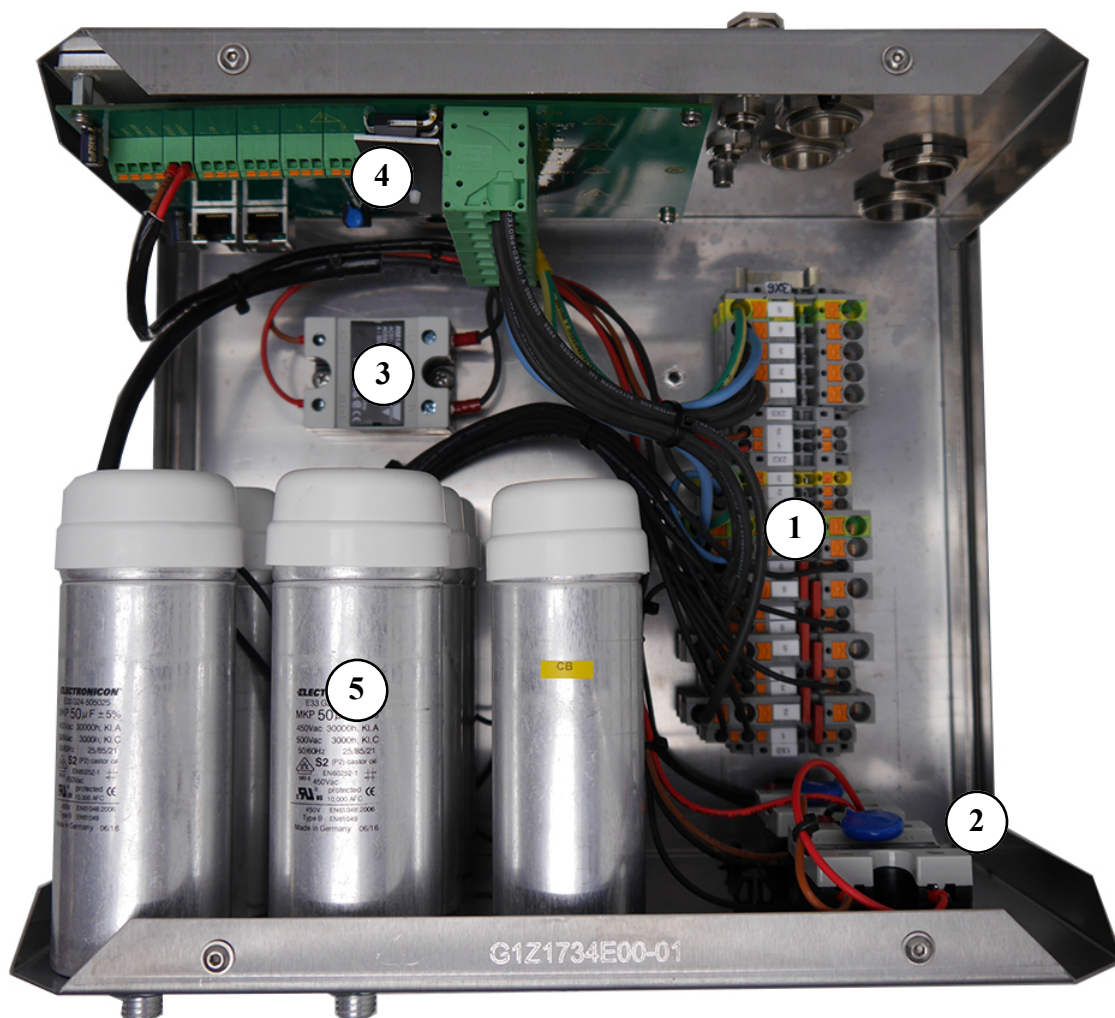

1. Terminal block for excitation
2. Boost solenoid
3. Solenoid for radiator fan

4. 3-Phase Current / Voltage measurement module
5. Capacitors
6. Fuse for radiator fan (single phase)



### 5.14.3 Installation with looped-in AC-Control box

All electrical safety installations have to be made on board (RCD etc.).

Fig. 5.14.3-1: Installation with looped-in AC Control box

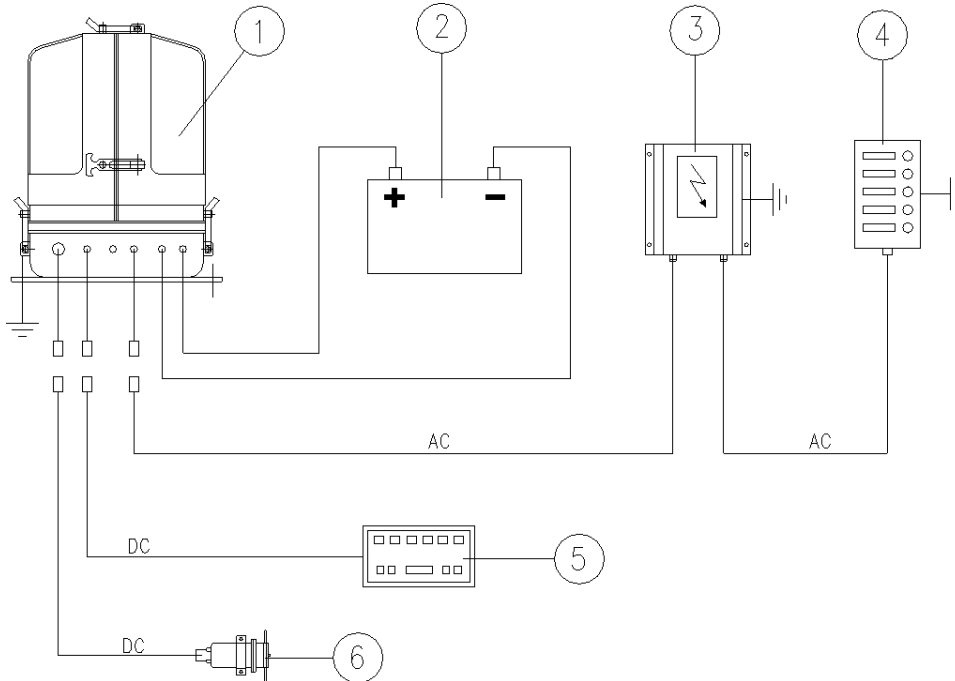

- 1. Generator
- 2. Battery
- 3. AC-Control box

- 4. Distribution panel
- 5. Remote control panel
- 6. Diesel pump

### 5.14.4 Installation AC-Box / Distribution panel connected separately

Fig. 5.14.4-1: Installation AC-Box / Distribution panel connected separately

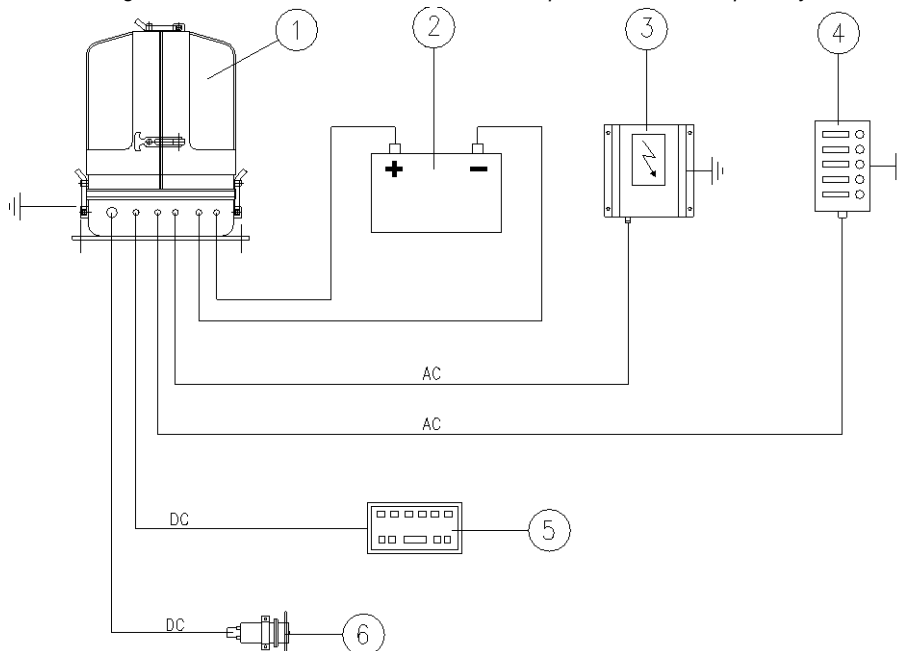

- 1. Generator
- 2. Battery
- 3. AC-Control box

- 4. Distribution panel
- 5. Remote control panel
- 6. Diesel pump



---

### 5.14.5 Electronic voltage control xControl/fpControl

---

The xControl/fpControl controls the generator voltage and motor speed. An actuator/servo on the injection pump can increase the engine speed compared to the idle speed.

If the generator runs without load, the frequency should be approx. 48,5 - 49 Hz (50 Hz System) or 58,5 - 59 Hz (60 Hz System). The frequency (equates to the speed) can be increased by up to 8%. This ensures that the engine speed is increased when there is an extra load. The maximum speed is achieved when 80% load is reached.

The speed gauge is governed and limited by an adjusting screw, above and below. Adjustment of this screw may not occur without the expressive approval of the manufacturer.

All signals pass through the circuit board in the xControl/fpControl box. The signal impulse for the Servo is passed to the electric motor.

### 5.14.6 Connection to the AC on-board power supply

---

#### 5.14.6.1 Protective conductor

The generator is equipped with a PEN protective conductor system as standard. A Neutral and a PE line are separate on the power out cable.

If a separate protective conductor is necessary (i. e. according to national safety regulations), the bridge circuit at the generator and the AC-Control box between neutral and generator housing has to be removed. Afterwards a separate protective conductor has to be installed and connected to all the system's attached metallic housings.

It is recommended to provide a voltage indication (voltmeter) and also a power indication, if applicable, in the installation system. The voltmeter (and power indication, if applicable) has to be installed behind the selector switch so that the voltage for every possible voltage source may be indicated. A separate voltmeter for the generator itself, is therefore not required.

#### 5.14.6.2 Electrical fuse

It is absolutely essential that the electrical system installation is inspected by a qualified electrical technician. The generator should have its own AC input electrical fuse. This fuse should be sized so that the rated current of the generator on each of the individual phases is not exceeded by more than 25%.

Data for gensets with power output greater than 30 kW on request!

The fuses must be of the slow type. A 3-way motor protection switch must be installed to protect the electrical motor.

#### 5.14.6.3 Required cable crosssections

The following recommended electrical cable dimensions (cross sections) are the minimum required sizes for a safe installation (see section 10.7, "Cable cross-section," on page 159).

---

## 5.15 Generator DC system installation

---

The Panda generators from 6000 upwards have their own dynamo to charge a DC starter battery.

It is recommended to install an additional starter battery for the generator.

The generator is then independent from the remaining battery set. This enables you to start the genset at any time with its own starter battery even if the other batteries are discharged. A further advantage of a separate starter battery is that it isolates the generator's electric system from the rest of the boat's DC system, i.e. minus pole (-) is not connected electrically to Earth/Ground.

The generator is then Earth/Ground free.



## 5.15.1 Connection of the starter battery block

An own separate starter battery must be installed for the generator.

The positive cable (+) of the battery is attached directly at the solenoid switch of the starter motor. The negative cable (-) of the battery is attached underneath the starter motor at the engine mount.

**Panda Generators Panda 6000 and higher normally provided with an alternator/dynamo to charge the starter battery. At generators without alternator/dynamo it is needed to charge the starter battery with an external battery charger.**

**NOTE:**



**Make sure that the voltage of the starter battery fits to the start system voltage**

**ATTENTION!**



f.e. 12 V starter battery for a 12 V start system

f.e. 24 V starter battery for a 24 V start system (2x12 V batteries in a row)

**To avoid large voltage drops the battery should be installed as near as possible to the generator. The positive terminal of the battery is attached at the red cable, the negative pole at the blue cable.**

**NOTE:**



It must be guaranteed that first the cables are attached at the generator and then at the battery.

**ATTENTION!: Consider correct connection sequence**



### Battery connection

**ATTENTION!: Right connection of the battery.**

**Wrong connection of the battery bank can cause a short-circuit and fire.**



Install an appropriate fuse and a battery circuit breaker in the plus pole cable of the battery, but with a distance to the battery of up to 300 mm (12 inch) at maximum.

The cable from the battery to the safety device must be secured with protective pipe/sleeve against chafing through.

For the connection use self-extinguishing and fire-protected cables, which are appropriate for temperatures up to 90 °C, 195 °F.

The batteries must be installed in such a way that they do not chafe through or other mechanical load can be stripped.

The battery poles must be secured against unintentional short-circuit.

The positive battery cable within the generator must be shifted in such a way that it is protected against heat and vibrations by appropriate sleeve/protective pipe. It must be shifted in such a way that it does not affect rotary parts or parts, that become hot in operation, e.g. wheel, exhaust elbow union, tail pipe and the engine. Do not lay the cable too tautly, since otherwise it could be damaged.

Make a test run after the installation and check the laying of the batteries during the test run and afterwards. If necessary, correct the laying.

Examine regularly the cable laying and the electrical connections.

### Positive battery cable

The positive (+) battery cable is connected directly to the solenoid switch of the starter.

Fig. 5.15.1-1: Positive battery cable

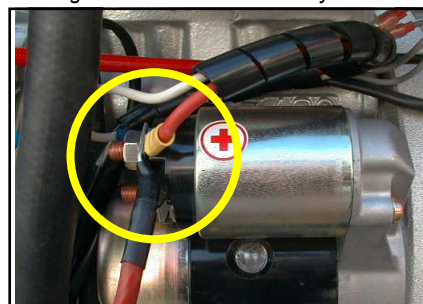

### Negative battery cable

The negative (-) battery cable is connected to the engine foot.

**Note! The battery negative pole may not be connected with the boat ground or with the protective grounding of the 12 V installation!**

Fig. 5.15.1-2: Negative battery cable

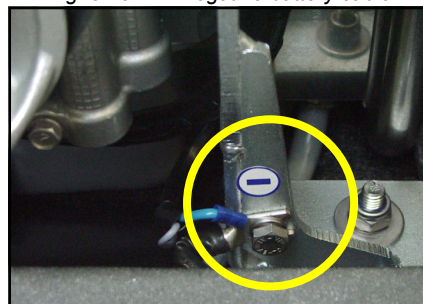

### DC starter motor

All Panda generators are equipped with an independent DC starter motor.

1. Solenoid switch for starter motor
2. Starter motor

Fig. 5.15.1-3: DC starter motor

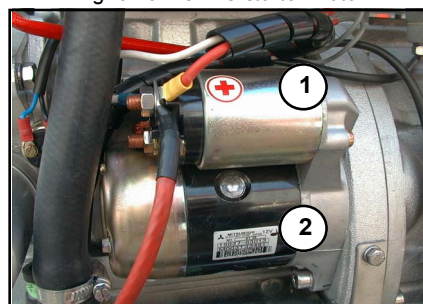
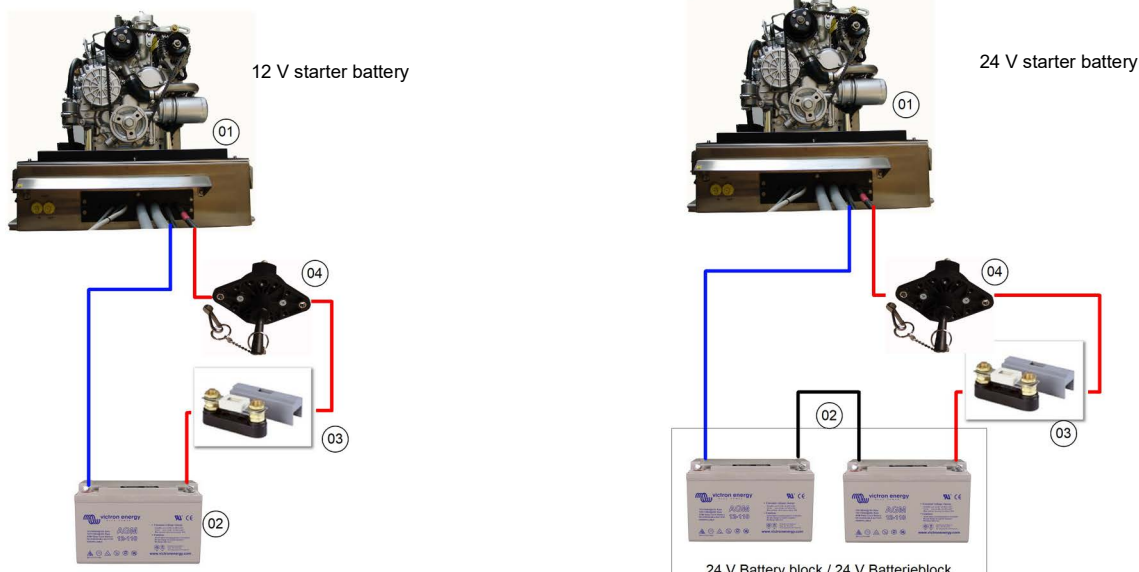

Fig. 5.15.1-4: Connection starter battery - schema



1. Generator
2. Battery block

3. Fuse
4. Battery main switch



## 5.15.2 Connection of the remote control panel - see separate control panel manual

## 5.16 Connection Box – Generator xControl – CB-G

The xControl CB-G is the external interface of the generator equipped with a xControl System.

Fig. 5.16-1: CB-G

The panel and the fuel pump are connected at this interface. It is optionally possible to connect emergency stop, auto start, load contactor and boost.

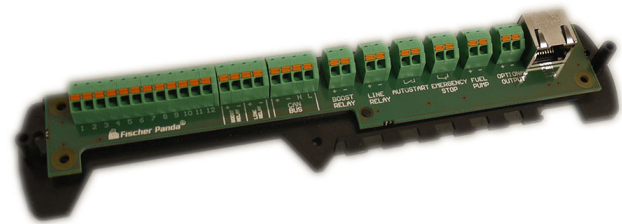
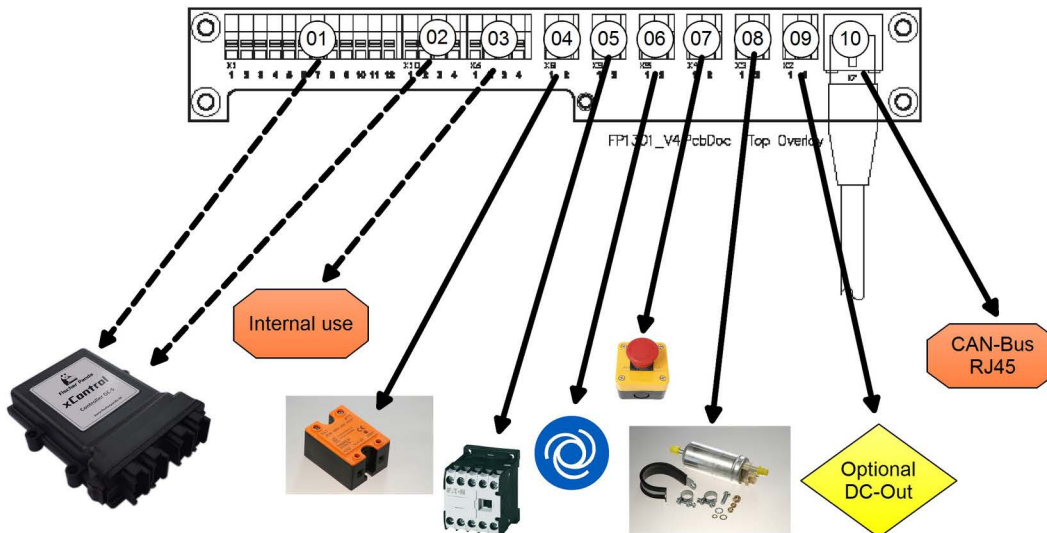

Fig. 5.16-2: CB-G



- |                                 |  |
|---------------------------------|--|
| 01. Terminal xControl ECU       | 06. Terminal automatic start                           |
| 02. Terminal xControl ECU       | 07. Terminal emergency stop                            |
| 03. FP CAN-Bus for internal use | 08. Terminal Fuel pump                                 |
| 04. Terminal boost relay        | 09. Terminal optional DC-Out                           |
| 05. Terminal line relay         | 10. Terminal FP CAN-Bus (external xControl components) |

### 5.16.1 xControl ECU

The xControl ECU is the main module of the xControl.

Installation and modification are only allowed by Fischer Panda or authorized service points.



---

### **5.16.2 FP CAN-Bus for internal use**

---

The FP CAN-Bus terminal is for internal use only.

### **5.16.3 Boostrelay (optional)**

---

The Boostrelay connect extra capacitors to the generator for a short time to compensate peak load.

### **5.16.4 Line Relay (optional)**

---

The line relay protect the consumers against undervoltage and overvoltage. At standard following parameters are set:

Warning: +/- 6% generator nominal voltage.

Relay off: +/- 10% generator nominal voltage.

### **5.16.5 Autostart (optional)**

---

With the autostart the generator can be started by an external signal (f.e. SPS).

### **5.16.6 Emergency Stop (optional)**

---

With the emergency stop the generator will be stopped as soon as possible. All DC out will be disconnected (Line relay, fuel pump, optional DC out etc.).

If not used, the connection must be bridged.

### **5.16.7 Fuel pump**

---

The fuel pump is controlled by the xControl ECU.

### **5.16.8 Optional DC-OUT**

---

The optional DC out is pre configured.

At PMS generators for the external electrical water pump.

At vehicle generator for the fan control.

### **5.16.9 FP CAN-Bus RJ45**

---

Connection for the external components of the xControl (Controlpanel, Paralleling Device etc.). At the end a termination resistor must be set in.

## **5.17 Radiator fan control / electronic fan control**

---

---

To control the radiator fan, various controls/electronic controls can be chosen from the Fischer Panda delivery program.



In the following the basic functions of the fan controls are described. The original manual/ data sheet with further informations of the fan control must be respected.

Note!:



## 5.18 Standard fan control for 1-phase and 3-phase generators

Optional the generators will be equipped with a one step fan control.

### Fan control 230 V

*Sample picture*

Fig. 5.18-1: Fan control 230 V



Fig. 5.18-2: Fan control 230 V

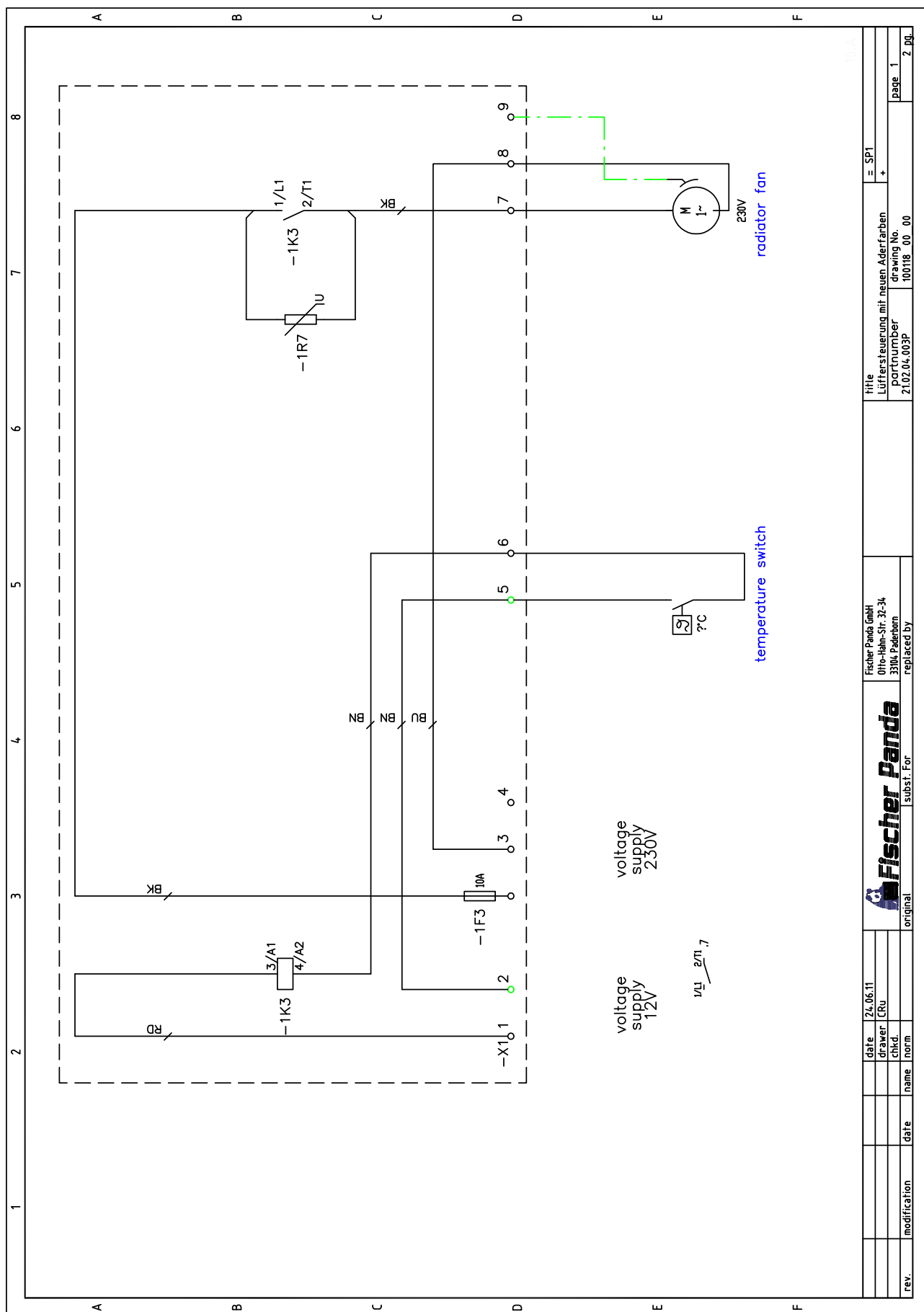

rev.	modification	date	name	norm	chkd.	date	drawer: CRU	date	24.06.11	original	subst. For	replaced by	3904_Palenborn	07ro-Hahn-Sfr. 32-34	Fischer Panda GmbH	10018_00_00	partnummer	21.02.04.003p	partnerumber	10018_00_00	drawing No.	+	= SP1	page 1	2.0g.



## 5.19 Electronic fan control for DC fans RE 0201

For DC Fans the fan control RE 0201 can be used.

Fig. 5.19-1: Electronic fan control for DC fans RE 0201



## 5.20 Brief description

Temperature-dependent continuous speed controlling device for one or two DC-fans.

### 5.20.1 Function

The speed regulation of the fan is made by pulse tracing modulation (PWM) of the operating voltage. Pulse/no pulse ratio becomes over an external temperature sensor (NTC resistance to attach at clamp 7 and 8) dependent on the coolant temperature. Between the lower limit temperature (starting temperature) and the upper limit temperature the fan is controlled with 30 to 100 % of the available operating voltage (PWM = 30 % to 100 %).



Potentiometer for adjustment concerning temperature and PWM behaviour	
<b>Poti Start:</b>	Adjusting the starting temperature (fan start-up). The start temperature is with left stop 60 °C and with right stop 80 °C. Ex factory a starting temperature of 70°C is adjusted (potentiometer position: In the middle).
<b>Poti Window:</b>	Adjusting the temperature window: With the potentiometer „Window“ the size of the window between starting temperature and temperature for full number of revolutions (upper limit temperature) can be adjusted. The temperature window can be adjusted from 5 °C to 20 °C. Is the starting temperature adjusted to 70°C and the temperature window to 10 °C thus the fan start-up with 70°C and reaches the maximum speed with 80°C (upper limit temperature). Ex factory a temperature window of 12,5 °C is adjusted (potentiometer position: In the middle).
<b>Poti Freq:</b>	Adjusting of the PWM frequency. Desired to many customers a potentiometer was added for changing the PWM frequency. A selection of the frequency between approx. 1,7 and 3,5 kHz is possible, which can serve for the avoidance of unwanted oscillation/resonances. Ex factory a PWM frequency of 2 kHz is adjusted.

Function of the temperature sensors (NTC-resistance, extern und intern):	
<b>extern:</b>	Over this temperature sensor the coolant temperature is collected. The starting temperature (fan start-up) and the upper limit temperature can be adjusted by means of potentiometer present at the plate. The PWM ratio starts with the exceeding of the starting temperature with approx. 40% (for 2 seconds), so that the fan starts reliably. According to expiration of the 2 seconds the PWM ratio is determined by coolant temperature and potentiometer adjust. Since the coolant temperature will not continue to rise in the 2 seconds, the PWM ratio will jump back to the minimum value of 30 %. At, from here, far rising coolant temperature, the PWM ratio will then rise linear with the temperature. If the upper limit temperature is nearly reached, the PWM ratio rose to 85 %. By 85% to 100 % PWM ratio with reaching the upper limit temperature switching over is made by one step, in order to avoid very short turn-off times. Likewise switch-back is made with falling coolant temperature of 100 % to 85% PWM ratio. If the coolant temperature falls under the starting temperature, the minimum PWM ratio is not fallen below of 30%, but remains constant. If the coolant temperature sinks approx. 3°C under the starting temperature, then the fan is switched off completely. All data exclusively apply on use of the temperature sensor type S891-100k of the manufacturer Epcos.
<b>intern:</b>	Over this temperature sensor the temperature of the output stage is collected. If the temperature of the output stage rises over 85 °C, the PWM ratio, independently of the coolant temperature, is set to 100 %, in order to avoid the switching losses and cool the output stage down again. If the temperature of the output stage continues to rise nevertheless and beyond 90 °C, the fan controller switches itself off. <b>NOTE: The cooling of the generator is not ensured anymore.</b> If the output stage temperature sinks again under 85 °C, the fan controller restarts itself. Such output stage temperatures cannot occur however with intended use of the equipment.

Light emitting diodes: The 3 light emitting diodes (LED's) indicate the operating condition of the fan controller and have the following meaning:	
<b>LED (green):</b>	Shines with normal operation. After the self check and successful recognizing of the sensors the fan controller jumps into the normal operating condition, in which the fan regulates, if the temperature lies in the appropriate range.
<b>LED (yellow):</b>	Shines if the fan controller is in slave-mode.
<b>LED (red):</b>	Shines with the occurrence of the following errors: Incorrect external temperature sensor. If the temperature sensor for the cooling water is defective or the feeder line to it interrupted (cable break), then the fan is accessed with 100 % PWM. Incorrect internal temperature sensor. If the temperature sensor for the output stage is defective or the feeder line to it interrupted (cable break), then this is indicated over the LED. The fan controller continues working normally. Overheating of the output stage. If the output stage of the fan controller becomes too hot, then this switches itself off. Please read in addition the description of the function of the internal temperature sensor.

## 5.20.2 Master - Slave - Operation

Two or three fan controllers can be connected with each other that over one temperature sensor for the cooling water, all fan controllers can be operated synchronous.

On the connection between master and slave the PWM signal of the masters will transfer. The slave takes over of it the PWM ratio and the frequency. The slave spends its PWM impulse only then if that of the masters is terminated. Thus even load of the current supply is reached. The second slave (if available) regards the first slave as its master (see also drawing).

The slave operation is activated automatically, by the presence of a PWM signal at the slave control inlet. As soon as such a signal is present, the slave follows the control signal and ignores its own adjusts and its own temperature measuring input. If the master does not spend a PWM signal, because the coolant temperature is under its starting temperature, the slave drops back into the master operation and uses its own adjusts and analyses its own temperature measuring input. So that the slave behaves correctly now, a 100k fixed resistor must be attached at its temperature measuring input, which corresponds to a coolant temperature below the starting temperature.



The plug-able plug-in for the master-slave-connection and the 100k fixed resistor belong not to the normal scope of supply and must be ordered separately.

Fig. 5.20.2-1:

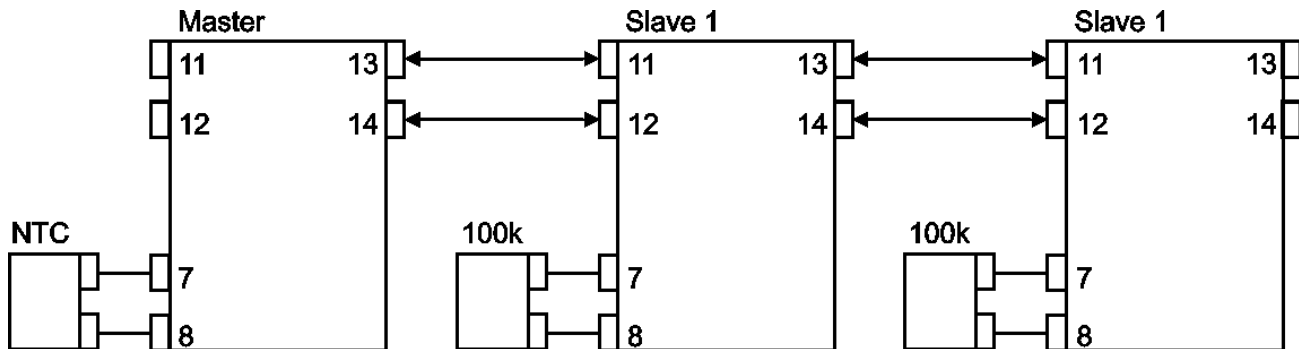

### 5.20.3 Function of the clamps for the Master-Slave-Operation

<b>Clamp 11+12:</b>	Control input for slave operation. Clamp 11 is the positive input. Clamp 12 is the negative input. The input is floating, so that via this input connected fan controllers of the same source can be supplied, without a ground loop develops.
<b>Clamp 13+14:</b>	Output for the master-slave-operation. At clamp 13 is the signal and at clamp 14 is ground.

### 5.20.4 Remote controlled switching on and off of the fan controller

The fan controller can be switched on and/or off over the connection „ON“ (clamp 9). If at connection „ON“ lies the same voltage as at the connection „BAT +“, the fan controller is switched on. If at connection „ON“ lies no voltage, the fan controller is switched off. If this option is not needed, then the connection „ON“ can be connected directly on the printed circuit board, over the solder joint J101, with the connection „BAT +“.

- J101 closed: Fan control always on
- J101 open: Fan control only on if operation voltage at connection „ON“

The solder joint J101 is seen from the direct line clamp directly behind the main safety device (main fuse) on the printed circuit board.

### 5.20.5 12 V / 24 V - Operation

For 12 V and/or 24 V-operation the pre-resistor for the operating voltage of control electronics must be adapted. This pre-resistor consists of two resistances, which are connected in series. For 12 V-operation one of these resistances is short circuit with the solder joint J102. For 24 V-operation the solder joint J102 must be opened. Additionally different safety devices (fuses) must be installed depending upon operating voltage.

#### **Main fuse (flat fuse on the printed circuit board):**

12 V-operation: 50 A flat fuse

24 V-operation: 30 A flat fuse

#### **Output fuse (plug fuse on the terminal block, each two pieces):**

12 V-operation: 25 A plug fuse

24 V-operation: 20 A plug fuse



## 5.21 Technical Data

<b>Characteristics</b>	
closed current (electronics off)	0,5 mA
closed current (electronics on)	10 - 15 mA
<b>Benchmark figure of the temperature control:</b>	
fan start-up	60 °C - 80 °C
max. number of revolution	65 °C - 100 °C
tolerance of the temperatures	± 5 %
<b>Maximum ratings</b>	
maximum ambient temperature (for operation)	50 °C
<b>Maximum ratings: Battery operation 12 V</b>	
nominal load operating voltage (continuity)	11 VDC - 14.4 VDC
load operating voltage (15min)	- 16.0 VDC
maximum idle speed operating voltage (3 sec)	17 VDC
nominal load current (continuity)	40 A
maximum load current (3 sec)	44 A
nominal voltage fan	12 VDC
<b>Maximum ratings: Battery operation 24 V</b>	
nominal load operating voltage (continuity)	18 VDC - 28.0 VDC
load operating voltage (15min)	- 28.8 VDC
maximum load operating voltage (3 sec)	30 VDC
idle speed voltage (continuity)	34 VDC
maximum idle speed operating voltage (3 sec)	36 A
nominal load current (continuity)	20 A
maximum load current (3 sec)	22 A
nominal voltage fan	24 VDC
<b>Maximum ratings: Transformer operation 12 V</b>	
sieving in the power supply	≥ 10000 µF 63 V (depending on the load current)
<b>data for secondary winding after rectification/sieving</b>	
nominal load operating voltage (continuity)	11 VDC - 14.4 VDC
load operating voltage (15min)	- 16.0 VDC
maximum load operating voltage (3 sec)	17 VDC
idle speed operating voltage (continuity)	28 VDC
maximum idle speed operating voltage (3 sec)	30 VDC
nominal load current (continuity)	40 A
maximum load current (3 sec)	44 A
nominal voltage fan	12 VDC
<b>Maximum ratings: Transformer operation 24 V</b>	
sieving in the power supply	≥ 10000 µF 63 V (depending on the load current)
<b>data for secondary winding after rectification/sieving</b>	
full load operating voltage (15min)	18 VDC - 28.0 VDC
load operating voltage (15min)	- 28.8 VDC
maximum full load operating voltage (3 sec)	30.0 VDC
maximum partial load operating voltage	36.0 VDC
idle speed operating voltage (continuity)	39.0 VDC
maximum idle speed operating voltage (3 sec)	40.0 VDC
maximum input peak voltage	44.0 VDC *1)
maximum output peak voltage	44.0 VDC *1)
nominal load current (continuity)	24 A



maximum load current (3 sec)	28 A
nominal voltage fan	24 VDC

*\*1) The maximum input and/or output peak voltage is measured over the appropriate clamps of the fan controller. It may be exceeded at no time. This applies independently of whether a voltage increased height was possibly caused by the fan controller or an external component. To this belong the switch off-transient of the fan (pulse width modulation = fan will be 2000 times per second switched on and off), and by outside switching operation caused glitches.*

- solder joint J101 closed
- solder joint J102 open
- main fuse 30 A installed
- output fuse 20 A installed

**Attention!: Configuration at delivery for 24 V-operation.**



**For 12 V-operation the installed fuses must be replaced against the provided fuses, as described above. The pre-resistors for the operating voltage of control electronics must be configured like above described.**

**Assembly: Vertical on standard rail, pay attention to good ventilation.**

**At breach of specification can destroy one or more components of the system or shorten the life span substantially.**

**Subject to change without prior notice.**

## 5.22 Electronic fan control for single phase fans PKE-2.5V\_Ziehl Abegg

The electronic fan control variety the fan rpm stepless.

### 5.22.1 Preset for the use with Fischer Panda generators

The Ziehl Abegg fan control is preset for the use with Fischer Panda generators. For the preset following data and jumper settings are used.

Fig. 5.22-1: Preset

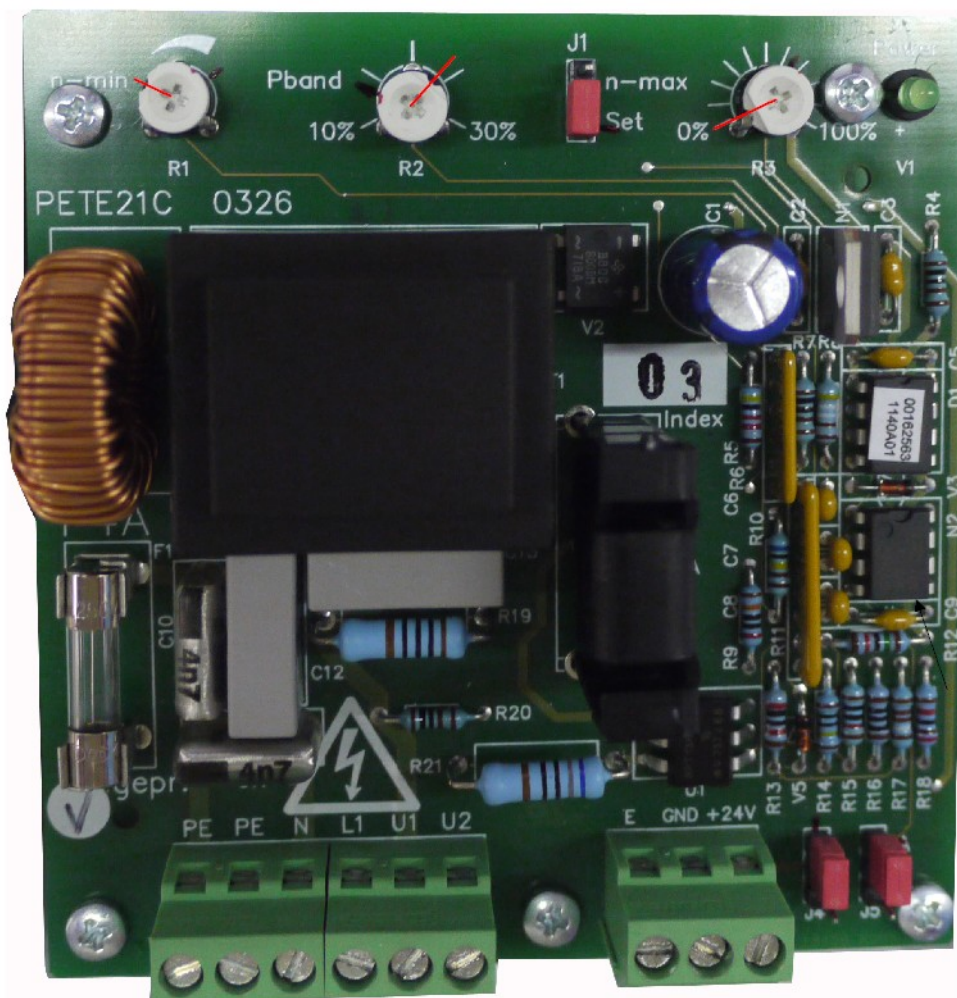



## 5.22.2 Connection of the sensor (Ziehl Abegg KTY)

The sensor is connected to E/GND. A resistor 4,7kOhm must be connected parallel to the sensor.

Fig. 5.22.2-1: Connection plan

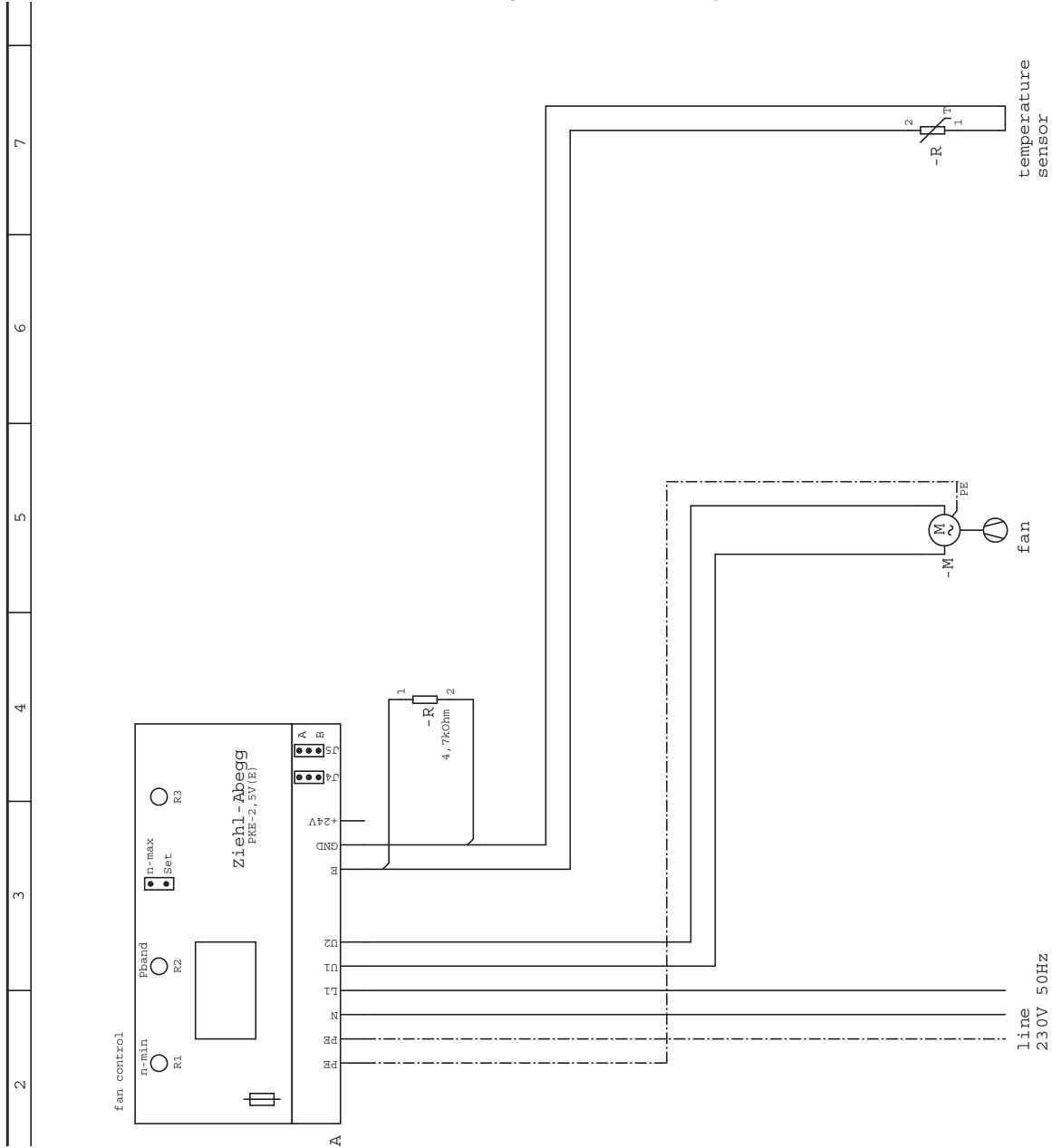



## 5.23 Electronic fan control for single phase fans PXET6Q\_Ziehl Abegg

The electronic fan control variety the fan rpm stepless.

### 5.23.1 Preset for the use with Fischer Panda generators

The Ziehl Abegg fan control is preset for the use with Fischer Panda generators. For the preset following data and jumper settings are used.

Fig. 5.23-1: Preset

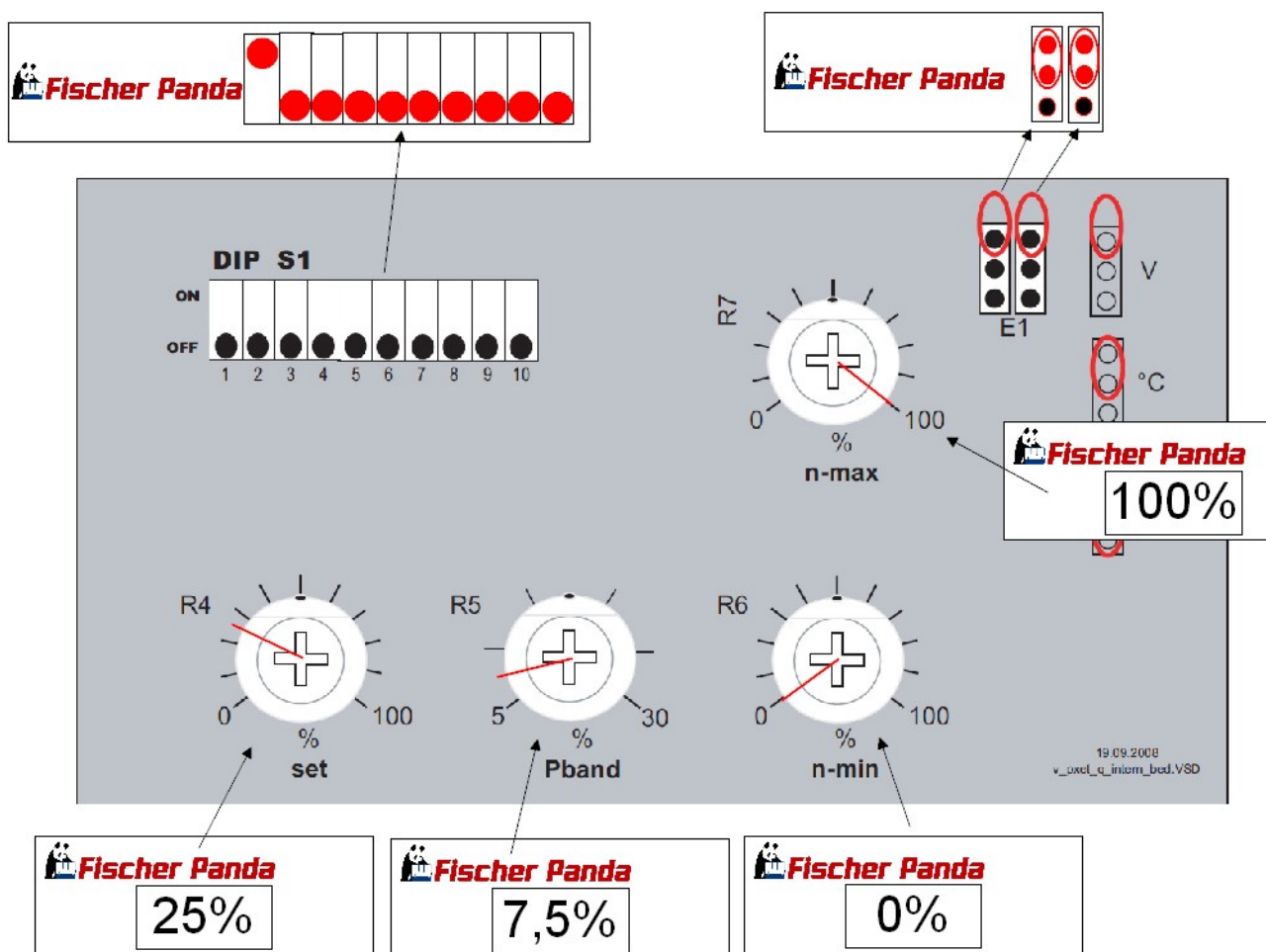



## 5.24 Electronic fan control for 3 phase fans PKD T5/PKD M10 Ziehl Abegg

The electronic fan control variety the fan rpm stepless.

### **Fan control PKD T5**

*representative picture*

Fig. 5.24-1: Fan control PKD T5





## 5.24.1 Configuration of the electronic fan control PKD T5 for Fischer Panda Generators

Fig. 5.24.1-1: Configuration of the fan control PKD T5 for Fischer Panda Generators

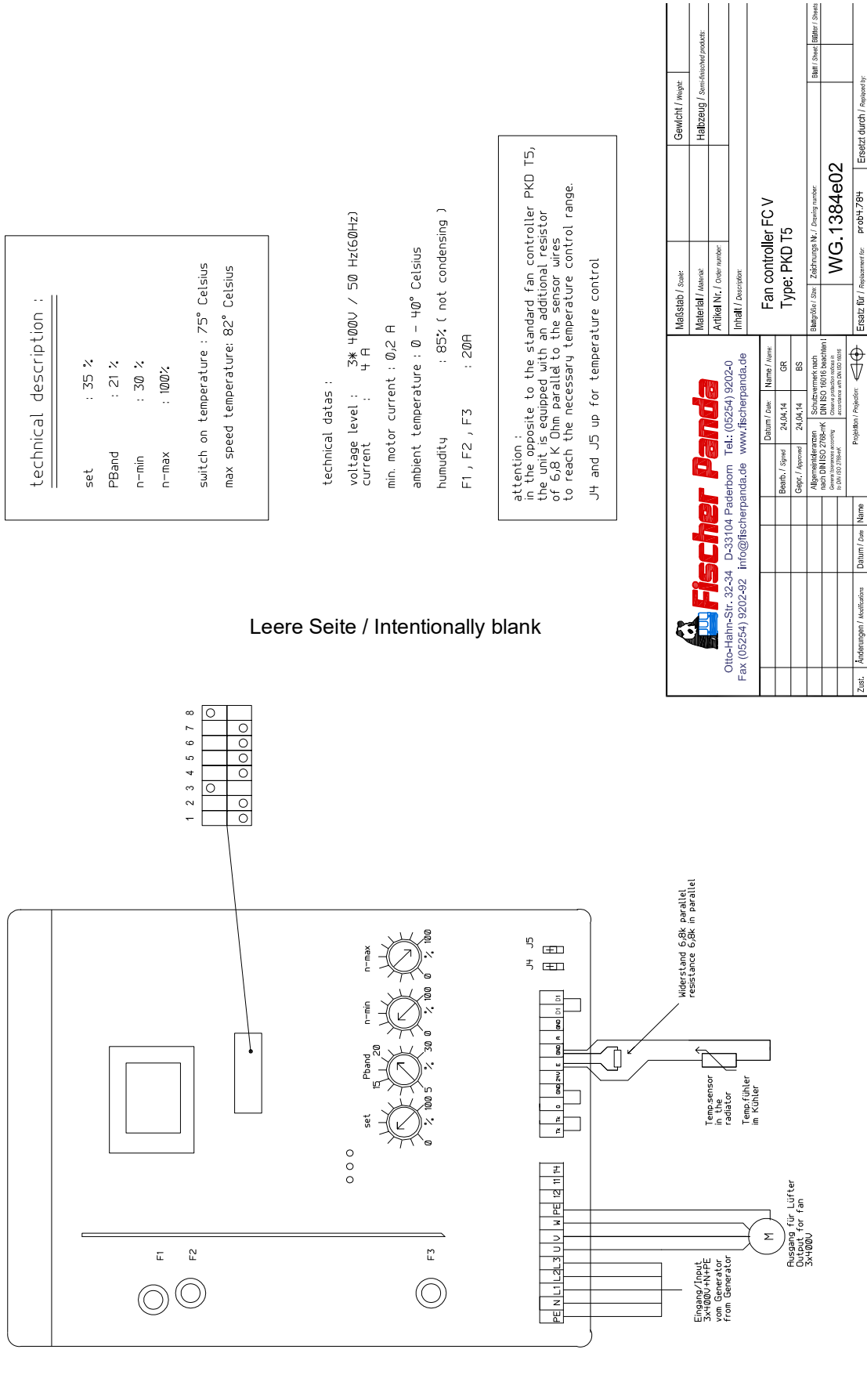



## 5.25 Configuration of the electronic fan control PKD M10 for Fischer Panda Generators

Fig. 5.25-1: Configuration of the fan control PKD M10 for Fischer Panda Generators

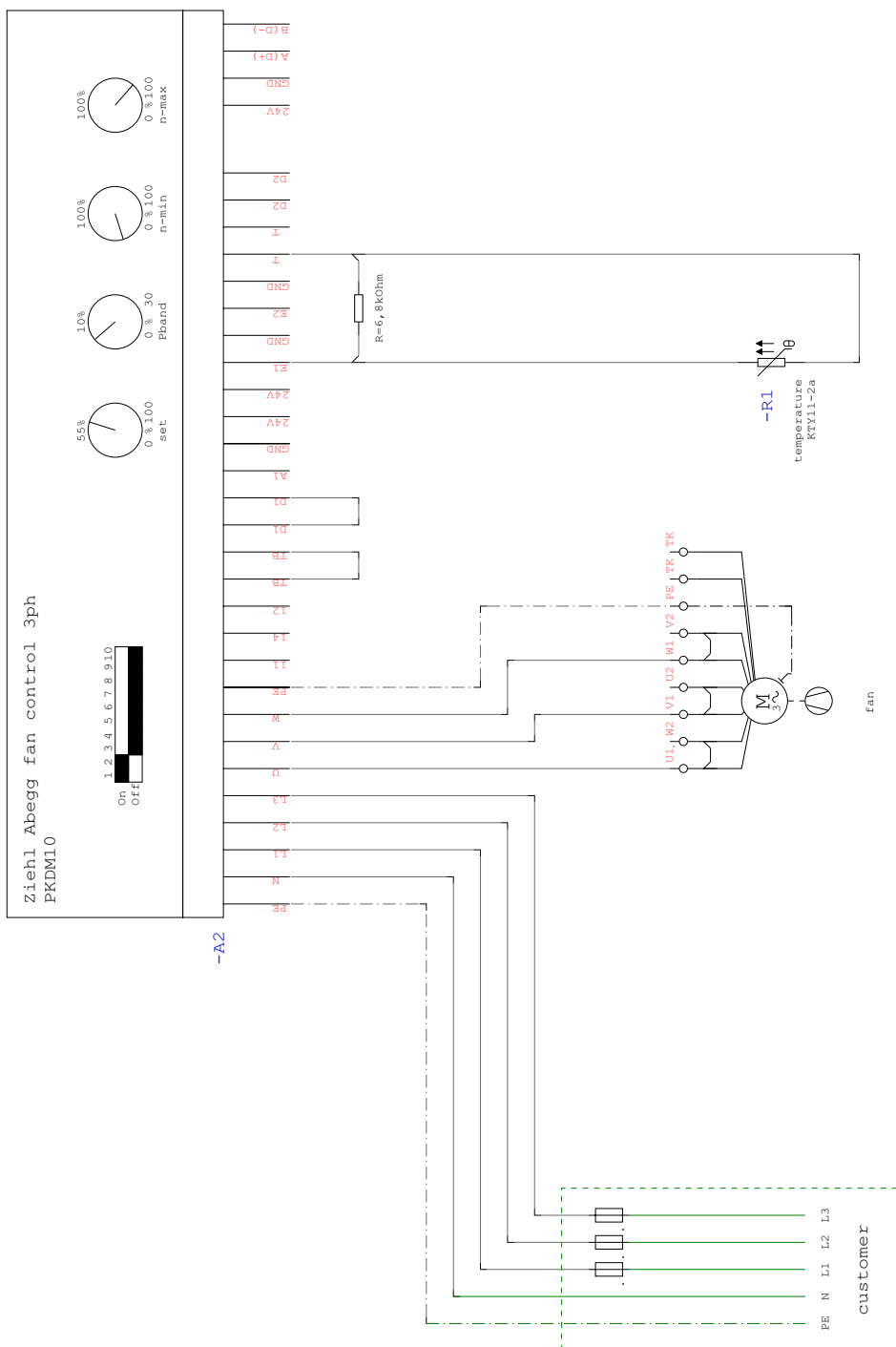



## 5.26 Insulation test

---

---

Once the electrical system installation is complete, a ground insulation test must be performed as follows:

**ATTENTION!**



1. Switch off all on-board electrical devices.
2. Start the generator.
3. Measure the AC-voltage with a voltmeter (adjust to Volt/AC) between:
  - a) generator housing and AC-Control box
  - b) generator housing and ground.

The measured voltage must not exceed 50 mV (millivolts).

4. Once the safety systems have been installed, they must be checked. If a Leakage Current Relay has been installed, it also has to be tested, in order to ensure that it functions properly. The individual phrases must be checked against each other, and between phase and ground, (the single phase or 4th phase also needs to be checked in this fashion).
5. If the generator is protected by a ground connection, then ALL electrical devices must also be connected to this "common" ground (usually ground contacts are attached to the devices' metallic housings).

The electrical system installation must also comply with the hook-up requirements of the shore current grid. Generally a leakage current relay is sufficient for safe electrical operation; however, this must be confirmed by the electrical safety standard in the region where the system is attached to a main land power grid. The relay has to meet the required safety standard regulations.

## 5.27 Set into operation

---

---

After the installation the generator must be brought in service. For this the „Service record and warranty registration must be worked through and filled out by the installing technical trained person.

This document must be handed out to the owner. The owner must be instructed for the operation, maintenance and hazards of the generator. These include the in the manual mentioned hazards and further ones, which are the result of the specific installation and the connected components.

**Send the original Service and warranty record to Fischer Panda to get full warranty. Make a copy for your hands. Note!:**





## 6. Generator operation instruction

### 6.1 Personal requirements

---

Only instructed persons are allowed to run the generator. Instructed Persons has read the manual of the generator and all ancillary components and external equipment. He must be acquaint with the specific risks and safety instructions.

Only persons who are expected to perform their tasks reliably are permitted as personnel. Persons whose reaction capability is impaired, e.g. through drugs, alcohol or medication are not permitted.

When selecting the personnel, the stipulations regarding age and occupation applying at the location must be observed.

#### 6.1.1 Hazard notes for the operation

---

**Please note the safety first instructions in front of this manual.**

**Notice!**



**Danger for life! - The generator can be equipped with a automatic start device. This means the generator can be started by an external signal.**

**Warning! Automatic start**



To avoid an unexpected starting of the generator, the starter battery must be disconnected before start working at the generator.

**Rotating parts inside of the generator**

**Attention! Danger to life**



Do not run the generator with removed sound cover. If it is necessary to test the generator without sound cover, pay special attention. Never do this work alone. Do all service, maintenance and repair with engine stopped.

**Danger for Life. Improper handling, operation, installation and maintenance can result in severe personal injury and/or material damage.**

**Attention! Danger to Life - High voltage**



Electrical voltages above 48 volts (battery chargers greater than 36 volts) are always dangerous to life). The rules of the respective regional authority must be adhered to. Only an electrician may carry out installation of the electrical connections for safety reasons.

### 6.2 General operating instruction

---

#### 6.2.1 Operation at low temperatures

---

The Generator can be started at temperatures down to - 20 °C, therefor the operation fluids like fuel, cooling water, lubricant oil ect. must be suitable for this temperatures. These should be checked before start. Cold start spray ect. are not allowed to use, or the warranty will be lost.



### 6.2.1.1 Pre-heating the diesel motor

Pre-chamber diesel engines are equipped with a quick glow plug. The maximum pre glow time should not exceed 20 sec. At 20 °C or more the pre glow time should be about 5-6 sec. Below 20 °C the pre glow time should be increased.

**If the operation fluids have been drained and then filled with cold weather fluids, always run the generator for 10 minutes to ensure the new fuel is present throughout the system.** **Note!**



### 6.2.1.2 Tips regarding starter battery

Fischer Panda recommends normal starter battery use. If a genset is required for extreme winter conditions, then the starter battery capacity should be doubled. It is recommended that the starter battery be regularly charged by a suitable battery-charging device (i.e., at least every 2 months). A correctly charged starter battery is necessary for low temperatures.

## 6.2.2 Light load operation and engine idle

---

If an engine is operated on a load less than 25-30 % of its rated output, the soot of the generator will be observed which may give cause for concern. The usual results of this operation are heavier than normal lubricating oil consumption, and oil leaks from the air and exhaust manifolds. This condition is particularly evident on standby generator set applications.

### 6.2.2.1 The soot of the generator is due to the fact that:

The cylinder temperatures are too low to ensure complete burning of all the fuel delivered.

A further result is that of abnormal carbon build-up on the valves, piston crowns and exhaust ports. Fuel dilution of the lubricating oil will also occur.

### 6.2.2.2 To prevent the soot of the generator following steps should be observed:

Running on light load should be avoided or reduced to the minimum period.

In a period of 50 operation hours the engine or generator set should be run on full load for four hours, to burn off accumulations of carbon in the engine and exhaust system. This may require the use of a 'dummy load'. The load should be built up gradually from 30 % to 100 % within 3 hours and hold at 100 % for one hour.

## 6.2.3 Generator load for a longer period and overload

---

Ensure the generator is not overloaded. Overloading occurs when the electrical load is higher than the generator can provide. If this occur for a longer period, the engine may be damaged. Overloading may cause rough running, high oil and fuel consumption, increased emissions.

For a long engine life, the long term load should not exceed 80 % of the nominal load. Long term load is the load over several hours. It is harmless for the generator to deliver full nominal power for 2-3 hours.

The whole conception of the Fischer Panda generator make sure, that the full power operation at extreme condition will not increase the engine temperatures over. Please note that the emissions of the generator also increase at full power operation.



## 6.2.4 Protection conductor: (AC Generators only)

---

The standard Panda generator is grounded. The 3-phase connection (delta) centre point is bridged to earth in the AC output terminal box (mounted on the generator). This is the initial earth safety point and is sufficient to ensure safe operation however only as long as no other system is installed. This system is adapted to enable test running of the generator before delivery.

The bridge to ground (PEN) is only effective when all components in the electrical system share a common ground. The bridge to ground can be removed and reconnected to another ground system if required for other safety standards.

Full voltage connections are mounted in the electrical cabinet. It must be ensured that the electrical cabinet is secured and closed while the generator is running.

The starter battery cable should be disconnected when work is being done on either the generator or the electrical system in order to prevent accidental starting of the generator.

## 6.2.5 Operating control system on the Fischer Panda generator

---

Fischer Panda generators are equipped with various sensors/temperatures switches. The combustion engine is further equipped with a oil pressure control switch, which switches the motor off, if the oil pressure sinks to a particular level.

## 6.3 Instructions for capacitors - not present at all models

---

---

### **Danger to Life - High voltage**

### **Caution!**

Do not touch the capacitor contact terminals!



The generator's electrical system requires two different groups of capacitors:

- A) The booster capacitors
- B) The operating capacitors

Both types are mounted in the electrical cabinet. (At some models direct on the generator)

Capacitors store an electrical charge. It is possible that even after they have been disconnected stored energy is still held. Therefore it is essential that the connectors are not touched.

Should it be necessary to check or test the capacitors, they should be shorted out by using an insulated screw driver.

The operating capacitors are automatically discharged when the generator is stopped in the normal way. The booster capacitors will be discharged through internal resistors.

For safety however, the capacitors have to be discharged (short circuited) prior to carrying out any work on the AC-Control box.

## 6.4 Checks before start, starting and stopping the generator

---

---

**See remote control panel data sheet/manual!**

**The instructions and regulations of the remote control panel data sheet/manual must be respected.**

### **Note!**

*Respect the safety instruction in front of this manual.*





---

## 6.5 Instructions for capacitors - not present at all models

---

### **Danger to Life - High voltage**

Do not touch the capacitor contact terminals!

### **Caution!**



The generator's electrical system requires two different groups of capacitors:

- A) The booster capacitors
- B) The operating capacitors

Both types are mounted in the electrical cabinet. (At some models direct on the generator)

Capacitors store an electrical charge. It is possible that even after they have been disconnected stored energy is still held. Therefore it is essential that the connectors are not touched.

Should it be necessary to check or test the capacitors, they should be shorted out by using an insulated screw driver.

The operating capacitors are automatically discharged when the generator is stopped in the normal way. The booster capacitors will be discharged through internal resistors.

For safety however, the capacitors have to be discharged (short circuited) prior to carrying out any work on the AC-Control box.



## 7. Maintenance Instructions

### 7.1 Personal requirements

---

The maintenance described here can be carried out by the operator unless otherwise indicated.

Further maintenance work may only be carried out by specially trained specialist personnel or authorized repairers (Fischer Panda Service Points). This is especially true for work on the valve setting, diesel injection system and for engine repair.

**The work described here can be taken as a guide. Since Fischer Panda does not know the exact installation and storage conditions, the work instructions and materials must be adapted by a local specialist. Damages caused by improper maintenance / repair are not covered by the warranty.**

**Attention!**



#### 7.1.1 Hazard notes for the maintenance

---

**Follow the general safety instruction at the front of this manual.**

**Note!**



**Danger for life! - The generator can be equipped with an automatic start device. This means the generator can be started by an external signal. To avoid an unexpected starting of the generator, the starter battery must be disconnected before start working at the generator.**

**Warning! Automatic start**



**Working at a running generator can result in severe personal injury. Therefore before starting work at the generator:**

**Warning! Risk of injury**



Make sure that the generator is stopped and the starter battery is disconnected to guarantee that the generator cannot be inadvertently started.

Do not run the generator with removed sound isolation cover

**Improper installation/maintenance can result in severe personal injuries or material damage.**

**Warning! Risk of injury**



- Always undertake installation/maintenance work when the generator is switched off.
- Ensure there is sufficient installation clearance before start working.
- Ensure tidiness and cleanliness at the workplace. Loose components and tools lying around or on top of each other are sources of accidents.
- Only perform installation work using commercially available tools and special tools. incorrect or damaged tools can result injuries.



**Oil and fuel vapours can ignite on contact with ignition sources. Therefore:**

- No open flames during work on the generator.
- Do not smoke.
- Remove oil and fuel residues from the generator and floor.

**Contact with engine oil, antifreeze and fuel can result in damage to health. Therefore:**

- Avoid skin contact with engine oil, fuel and antifreeze.
- Remove oil and fuel splashes and antifreeze from the skin immediately.
- Do not inhale oil and fuel vapours.

**Danger for Life. Improper handling, operation, installation and maintenance can result in severe personal injury and/or material damage.**

Electrical voltages above 60 volts are always dangerous to life). The rules of the respective regional authority must be adhered to. Only an electrician may carry out installation of the electrical connections for safety reasons.

**Generator, oil and antifreeze can be hot during/after operation. Risk of severe burns.**

**During Installation/maintenance personal protective equipment is required to minimize the health hazards.**

- Protective clothing
- safety boots
- protective gloves
- Ear defender
- safety glasses

**Disconnect all load during the work at the generator to avoid damages at the load.**

**Batteries contains acid or alkalis.**

Improper handling can result in battery explosion and leakage. Acid or alkalis can run out. An explosion of the battery is possible.

*See the operation and safety instruction from your battery manufacturer.*

Batteries contain corrosive acids and lyes.

Improper handling can cause the batteries to heat up and burst. Corrosive acid/lye may leak. Under unfavorable conditions, the battery may explode.

**Warning! Danger of fire**



**Danger! Danger of poisoning**



**Attention! Danger to Life - High voltage**



**Warning! Hot surface/material**



**Instruction! Personal protective equipment necessary.**

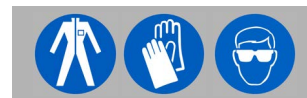

**Attention! Disconnect all load**



**Warning!**





Observe the instructions from your battery manufacturer.

The different liquid systems (Cooling System, Fuel system etc. may be pressurised after operation. When the system is opened, the pressure can be relieved abruptly and expel hot gases and fluids. Risk of injury due to parts flying about, burn hazard due to liquids and gases.

**Warning! System may be pressurised!**



## 7.2 Environmental protection

---

---

**Danger to the environment due to mishandling!**

**Environmental protection!**

Significant environmental damage can occur, particularly for incorrect disposal, if environmentally hazardous operating materials are mishandled. Therefore:



- Always observe the instructions mentioned below.
- Take immediate action if environmentally hazardous materials reach the environment. Inform the responsible local authorities about the damage in the case of doubt.

*The disposal must be performed by a specialist disposal company.*

## 7.3 Maintenance requirements

---

---

**Control before starting**

- Oil level
- Cooling system leaks
- Visual check for any changes, leaks oil drain system, v-belt, cable connections, hose clips, air filter, fuel lines

**Once a week**

- Lubrication of actuator-trapezoid thread spindle

## 7.4 Maintenance interval

---

---

For the maintenance intervals, see the „General information for vehicles generators“ which are attached to this manual.

For generators with dynamic maintenance interval (for example generators with iControl2). Further informations are in the remote control panel manual/data sheet.

**With the dynamic operation hours the service interval can be raised up to 30 % (200 h max.). Make sure that the dynamic operation hours are not reset accidentally between the service interval.**

**Note:**



## 7.5 De-aerating of the coolant circuit

---

---

**Particular hints for the de-aerating of the cooling system**

If the coolant has been drained or if air has permeated into the cooling system by other reasons, a careful ventilation of the cooling system is necessary. The de-aerating process has to be rerun several times.



**Open de-aerating screw at the cooling water pump.**

representative picture

*Fig. 7.5-1: De-aerating screw*

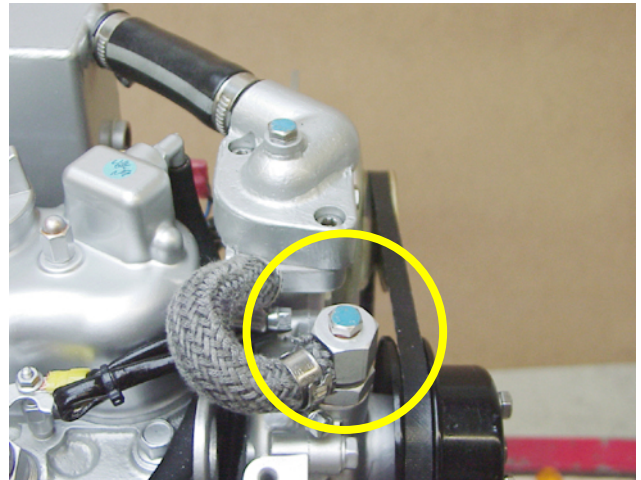

**Open de-aerating screw at the thermostat-housing**

representative picture

*Fig. 7.5-2: De-aerating screw*

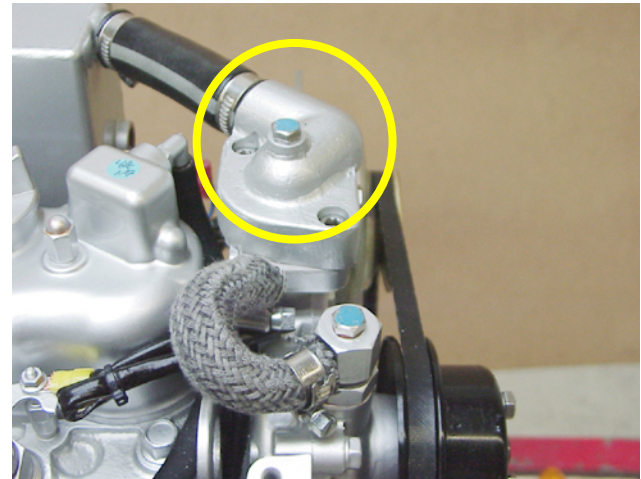

**Open de-aerating screw at the water-cooled silencer.**

representative picture

*Fig. 7.5-3: De-aerating screw*

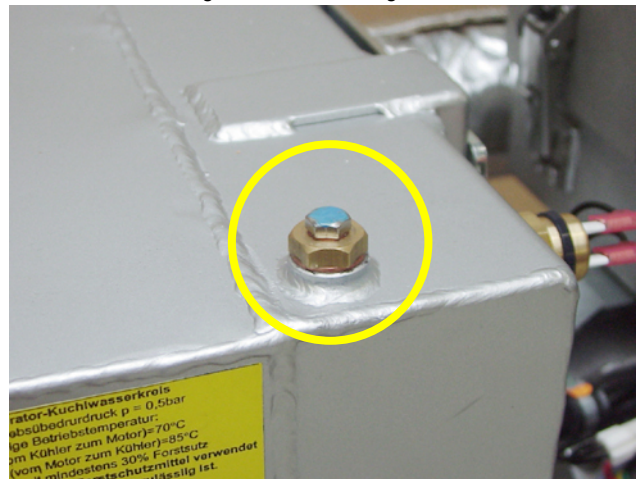

**Pour in coolant through the cooling water filler cap. The coolant flows in very slow.**

representative picture

*Fig. 7.5-4: Cooling water filler cap*



If it is to be recognized that the cooling water level does not sag any longer (with cold cooling water the cooling water level must cover the sheet metal in the exhaust elbow union), close the de-aerating screws and start the generator. Run the generator to maximally 60. Switch off generator.

**Open the cooling water filler neck again and also the de-aerating screws at the same time.**

**Fill in again cooling water.**

representative picture

*Fig. 7.5-5: Cooling water filler cap*



Repeat this procedure several times.

The generator can be started for 5 minutes, if there is no change. De-aerating must be then repeated two or three times.

To be sure that the coolant circulates it is very important that the hose pipe away from the genset also gets warm. After a short time the radiator and the reverse-flow pipe from the radiator to the genset also get warm.

Please wait until the temperatures raise more and check if the fan will activate.

It makes sense to, once again, repeat the de-aerating procedure after a few days, in order to ensure that remaining air bubbles have been finally removed.



## 7.6 Replacing the air filter

1. Open the closure on the right-hand side of the air intake housing

01. Closure

Fig. 7.6-1: Replace air filter

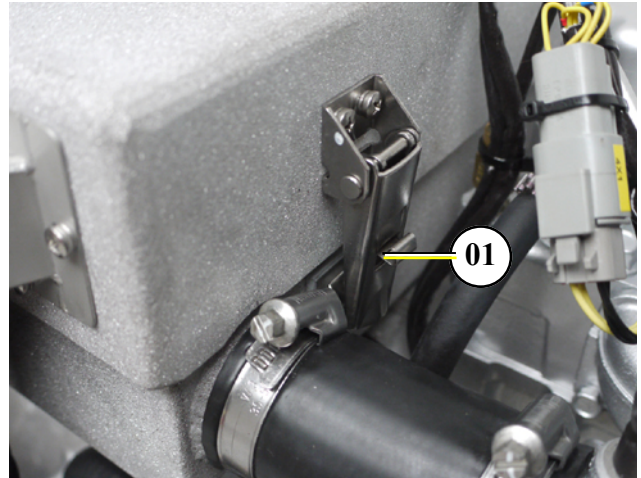

2. Open the closure on the left-hand side of the air intake housing.

01. Closure

Fig. 7.6-2: Replace air filter

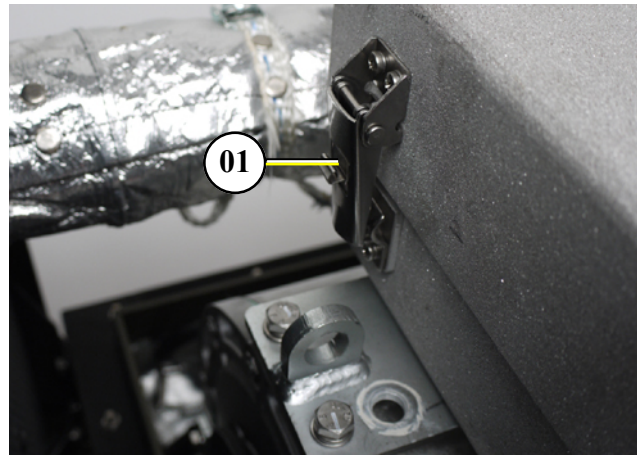

3. Lift up the housing cover and pull it backwards.

4. Replace the air filter.

5. To reinstall, reverse the order of steps.

Fig. 7.6-3: Replace air filter

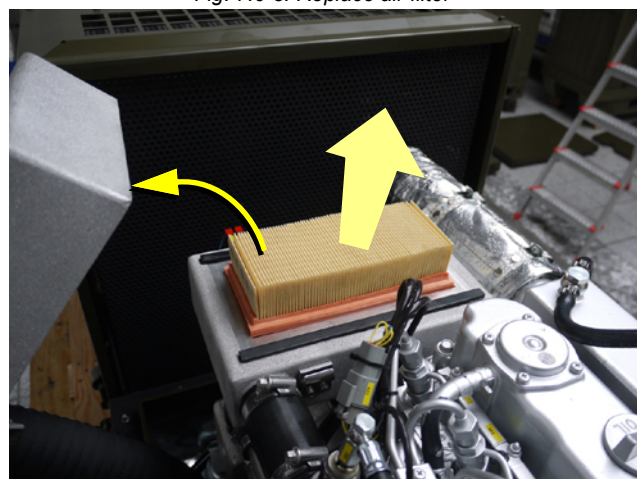

## 7.7 Replace the air filter

### Representative photos.

1. Use a screwdriver to open the tension spring. Place the screwdriver on the closing side between the tension spring and the handle and lever out the tension spring.



- 01. Tension spring
- 02. Air filter housing
- 03. Screw driver

Fig. 7.7-1: Replace air filter

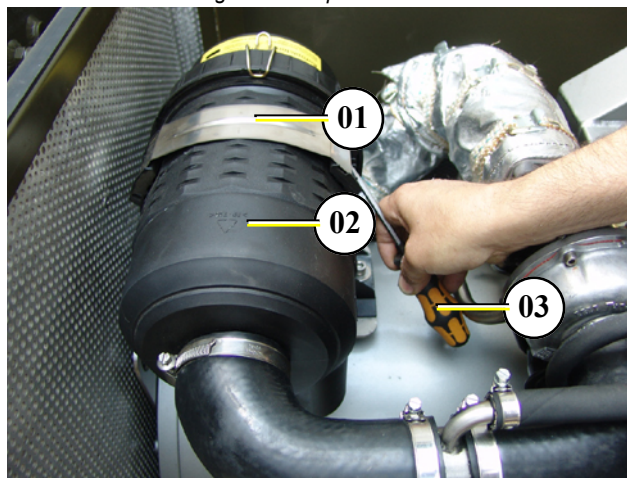

2. Lift the air filter housing.

- 01. Air filter housing

Fig. 7.7-2: Replace air filter

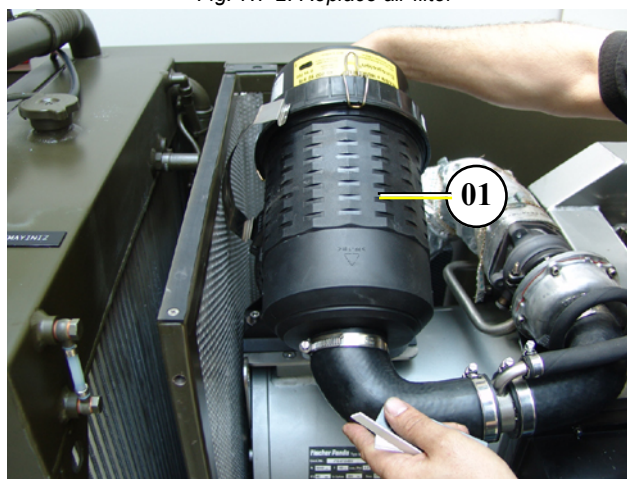

3. Release the three snap fastenings and remove the lower part of the housing.

- 01. Snap fastenings
- 02. Lower part

Fig. 7.7-3: Air filter clamp

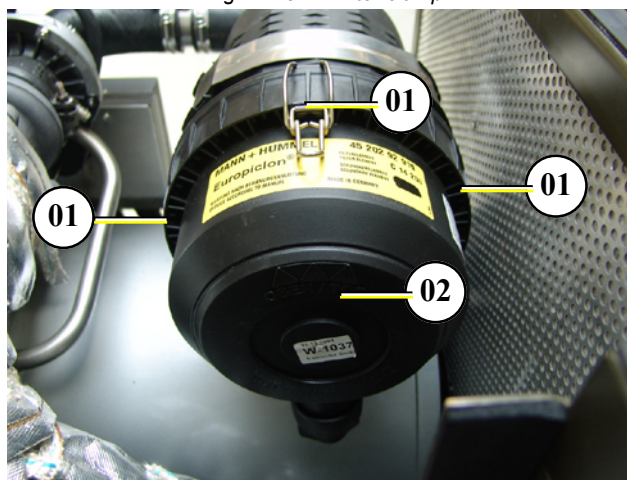



4. Remove the main element with a light turning movement completely from the inner support pipe.

*Fig. 7.7-4: Replace air filter*

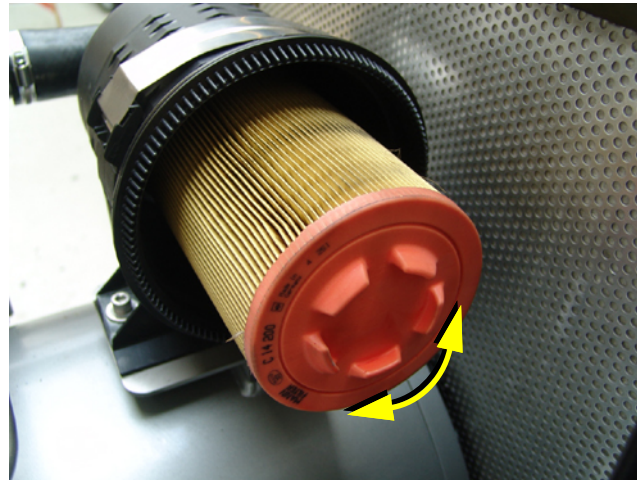

5. Clean the main element by blowing out with dry compressed air ( max. 5 bar) or replace the main element after 2 years at the latest.
6. Replace in reverse procedure.

*Fig. 7.7-5: Replace air filter*

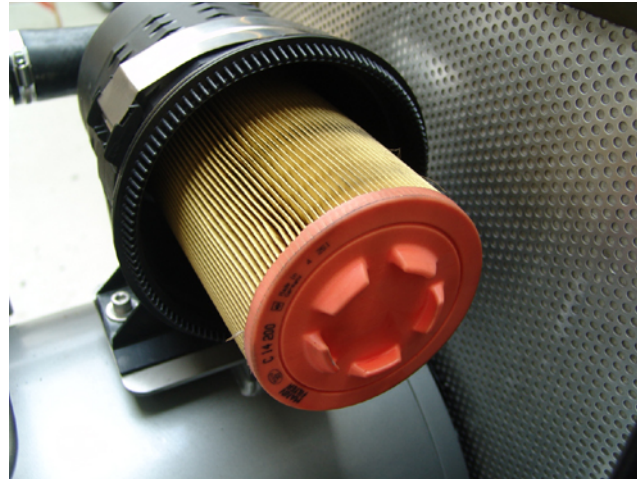

7. Blow out filter insert in folding direction maximum pressure: 5 bar.

*Fig. 7.7-6: Cleaning air filter*

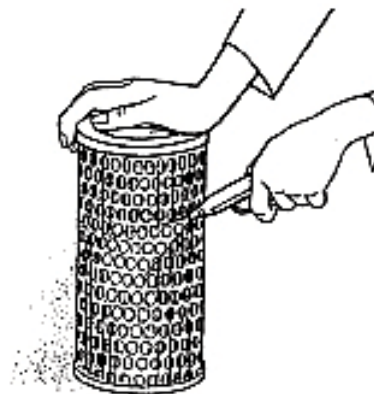

8. Blow out filter insert from the inside.

Fig. 7.7-7: Cleaning air filter

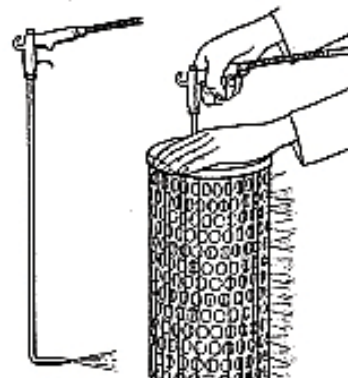

9. Check filter insert with penlight for damage.

Fig. 7.7-8: Cleaning air filter

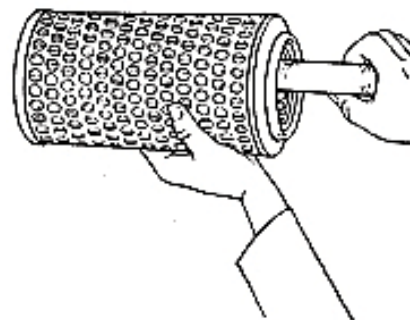

## 7.8 Checking oil-level

---

**You require:**

**paper towels / cloth for the oil dipstick**

The generator must be placed at level.

- with vehicular generators: Place the vehicle on a levelled surface.
- with PSC generators: Place the generator on a levelled surface.
- with marine generators: Measure the oil-level when the ship is not lop-sided.

Run the generator for about 10 minutes to ensure that the engine is warm. Wait for 3 minutes, so the oil can flow back into the oil pan.

**Generator and coolant can be hot during and after operating.**

**Caution: Burn hazard!**



Wear personal protective equipment. (Gloves, protective goggles, protective clothing and safety shoes)

- Assure generator against accidental start.
- Open the generator casing.
- Pull the oil dipstick out of the check rail.



- Clean oil dipstick.
- Put the oil dipstick back into the check rail and wait for 10 seconds.
- Pull the oil dipstick out of the check rail and read off the oil-level at the lower end of the stick.

### Oil dipstick

The oil-level is to be checked by means of the oil dipstick. The prescribed filling level must not cross the „Max“-mark.

*We recommend an oil-level of 2/3.*

*Sample picture*

Fig. 7.8-1: Oil dipstick - Sample

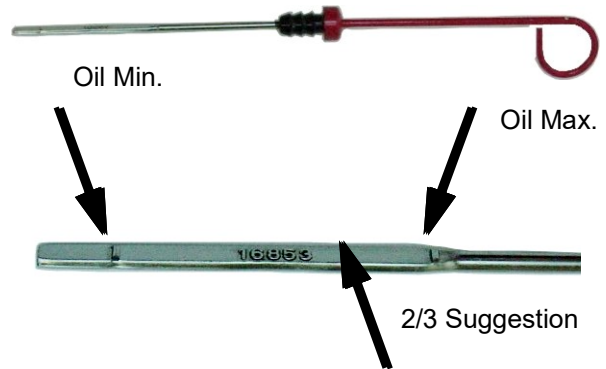

### Oil dipstick EA 300 Engine

The oil-level is to be checked by means of the oil dipstick. The prescribed filling level must not cross the „Max“-mark.

*We recommend an oil-level of 2/3.*

*Sample picture*

Fig. 7.8-2: Oil dipstick

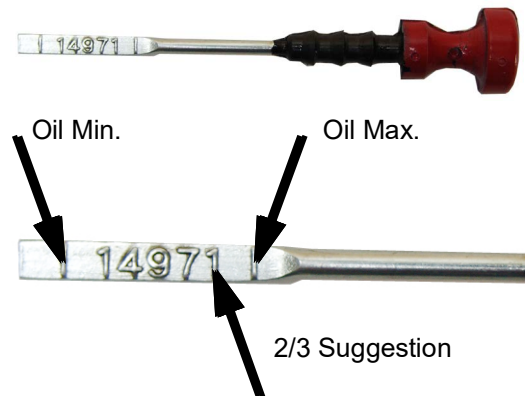

Oil should be refilled, if the oil-level is under 1/3 between the minimum and the maximum mark.

Fischer Panda recommends an oil-level of 2/3 between the minimum and the maximum mark.

## 7.8.1 Refilling oil

### You require:

#### Engine oil

1. Check oil-level as described under section 7.8, "Checking oil-level," on page 107.
2. Oil dipstick is pulled out of the check rail.
3. Open the oil filler cap.
4. Fill in oil (approx. 1/2 litre) and wait for about 2 min. so this it can flow into the oil pan.
5. Wipe off the oil dipstick and put it into the check rail.
6. Pull the oil dipstick out of the check rail and check the oil-level. See section 7.8, "Checking oil-level," on page 107.

If oil-level is still too low (under 2/3): repeat steps 4-6.



## 7.8.2 After the oil level check and refilling the oil

---

- Put the oil dipstick back into the check rail.
- Close the oil filling cap.
- Remove potential oil stains and splashes from the generator and surroundings.
- Close the generator casing.
- Remove lock against accidental generator start.

## 7.9 Replacement of engine oil and engine oil filter

---

---

You require:

- Engine oil. See attachment.
- New oil filter (not with generators with EA300 engines)
- Sealing for oil drain screw
- Personal protective gear
- Container to collect used oil (heat resistant and of sufficient size)
- Open-ended wrench for oil drain screw
- Paper towels and cloth
- Oil filter wrench
- Oil resistant mat, so prevent used oil from getting into underground water

The generator must be placed at level.

- with vehicular generators: Place the vehicle on a levelled surface.
- with PSC generators: Place the generator on a levelled surface.
- with marine generators: Change the oil when the ship is not lop-sided.

Run the generator for about 10 minutes to ensure that the engine is warm.

Wait for 3 minutes, so the oil can flow back into the oil pan.

**Generator and coolant can be hot during and after operating.**

**Caution: Burn hazard!**



Wear personal protective equipment. (Gloves, protective goggles, protective clothing and safety shoes)

1. Prepare generator.

- Assure generator against accidental start.
- Open the generator casing.
- with generators that have an external oil drain hose: Release the oil drain hose from the mounting.
- with generators that have an internal oil drain hose: Open the lead-through for the oil drain hose (left turn of the sealing). Pull out the sealing with the oil drain hose.



Place an oil resistant mat under the oil drain hose area and prepare the container.

2. Loosen oil filling cap

Unscrew the oil filling cap. This is necessary, because otherwise a vacuum will form and the oil can not completely drain off.

Sample picture

Fig. 7.9-1: Oil filling cap

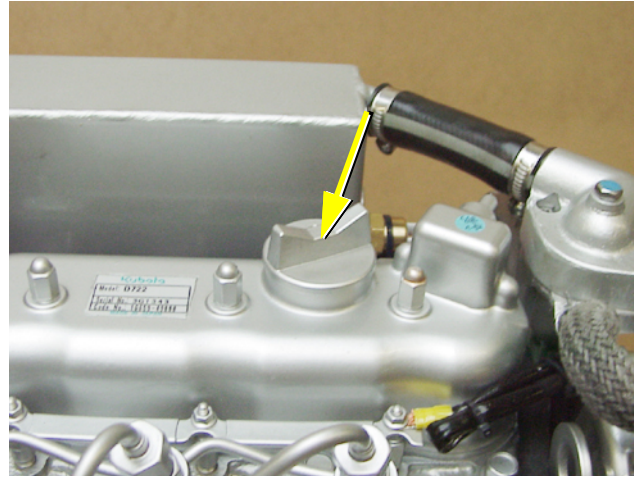

3. Open oil drain screw.

Unscrew the oil drain screw by means of the open-ended wrench from the oil drain hose (rotating direction left). Use a second open-ended wrench to lock. Make sure to do this over the container.

Use spanner size 17 mm.



Fig. 7.9-2: Oil drain hose



4. Discharge used oil.

Let the entire amount of oil drain out of the engine. This can take several minutes.

5. Remove used oil filter / clean oil screen

Release the oil filter by turning the filter wrench counterclockwise. The filter might be full of oil. Make sure to not spill anything and avoid skin contact.

Sample picture



Fig. 7.9-3: Oil filter

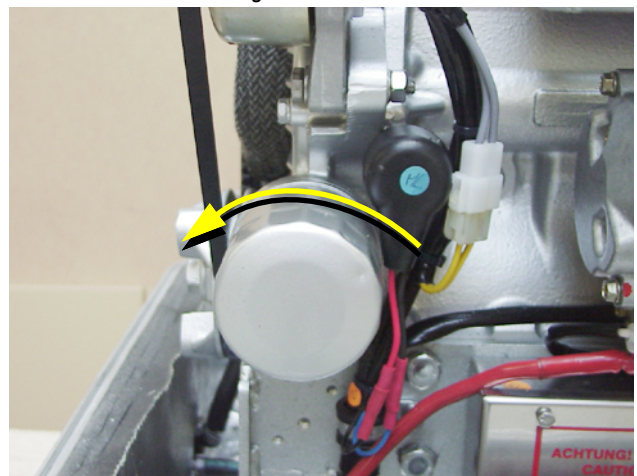



## Oil screen with generators with EA300 engines

The oil screen should be cleaned every 500 operating hours: to do so follow the instructions in the engine manual.

Use spanner size 17 mm.



Sample picture

Fig. 7.9-4: Oil screen

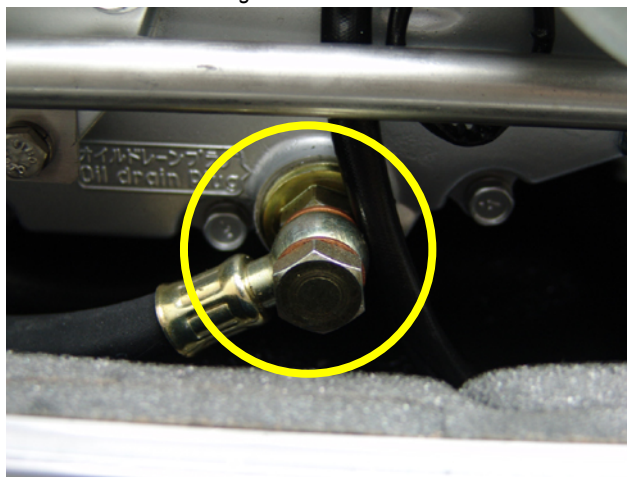

### 6. Preparing a new filter

Clean the engines' filter holder brush a thin oil layer on the sealing of the new filter.

Fig. 7.9-5: Oil screen sealing ring



### 7. Mounting the new filter

Carefully screw in the new filter by hand. It must not be tightened too much. Screw in the oil drain screw again and tighten it with the wrench. Use a new sealing for the oil drain screw.

### 8. Fill in oil. (oil fill capacity: see attachment)

Fill the engine oil into the engine via feed hopper. Check oil-level after every 2 litres with the oil dipstick.

### 9. Check proper filling level. See section 7.8, "Checking oil-level," on page 107.

When the proper filling level is reached, screw in the oil cap again. Run the engine for 10 minutes and then turn it off. Check the oil-level once more after several minutes with the oil dipstick. If it is too low, refill some oil.

### 10. Clean up

Wipe off all oil splashes from the generator and make sure that the drain screw has no leak.

## 7.9.1 After the oil change

- Put the oil dipstick back into the check rail.
- Close the oil filling cap.
- Remove potential oil stains and splashes from the generator and surroundings.
- Close the generator casing.
- Remove lock against accidental generator start.
- Duly dispose of used oil and filter.

Used oil is very toxic and must not be disposed with domestic waste. It is prohibited to dispose used oil with waste water! Make sure that used oil is disposed properly (e.g.: where oil is bought or at collection stations).



## 7.10 Verifying the starter battery and (if necessary) the battery bank

Check the condition of the battery. Proceed here as prescribed by the battery manufacturer.  
If from the battery manufacturer not otherwise mentioned.

### 7.10.1 Battery

#### 7.10.1.1 Check battery and cable connections

- Keep battery clean and dry.
- Remove dirty clamps.
- Clean terminal posts (+ and -) and clamps of the battery, and grease with acid-free and acid-resistant grease.
- When reassembling, ensure that clamps make good contact. Tighten clamp bolts hand-tight.

Fig. 7.10.1.1-1: Battery

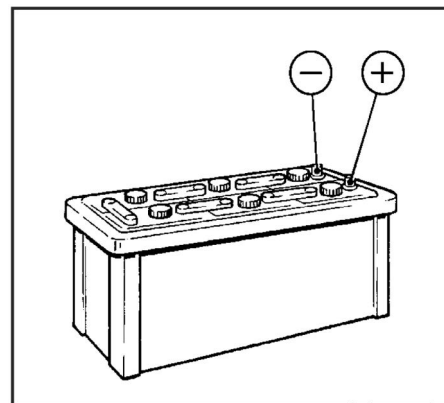

#### 7.10.1.2 Check electrolyte level

- Remove sealing caps 1.
- If testers 2 are present:
- Electrolyte level should reach the base of these.
- Without testers:  
The electrolyte level should be 10-15 mm above the top of the plates.
- If necessary, top up with distilled water.
- Screw sealing caps back in.

Fig. 7.10.1.2-1: Battery

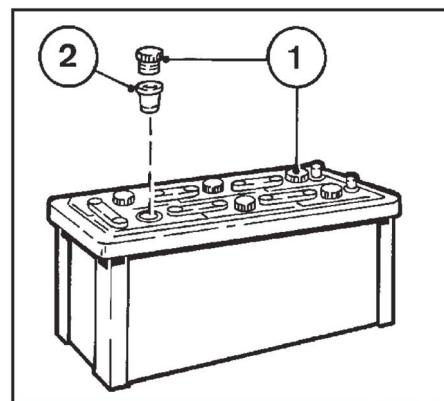



### 7.10.1.3 Check electrolyte density

- Measure the electrolyte density of individual cells with a commercial hydrometer. The hydrometer reading (see table on following page) indicates the battery's state of charge. During measurement, the temperature of the electrolyte should preferably be 20 °C.

Fig. 7.10.1.3-1: Battery

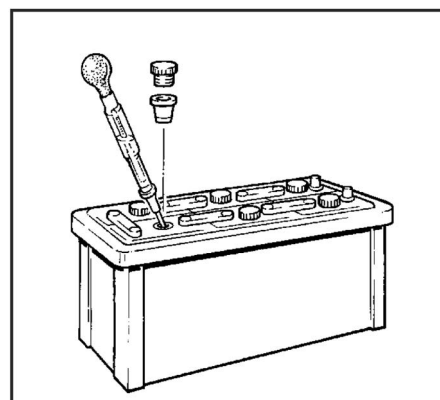

Electrolyte density		
in [kg/ l]		Charge status
Normal	Tropical	
1.28	1.23	well charged
1.20	1.12	semi-charged, re-charge
1.12	1.08	discharged, immediately charge

**The gases emitted by the battery are explosive! Keep sparks and naked flames away from the battery!**

**Attention**



**Do not allow battery acid to come into contact with skin or clothing!**

**Wear protective goggles!**

**Do not rest tools on the battery!**



## 7.11 Ventilating the fuel system

Normally, the fuel system is designed to ventilate air itself i.e. as soon as the electric starter motor starts operation the fuel pump starts working and the fuel system will be de-aerated after some time automatically. It is nevertheless essential to ventilate the system as follows prior to the first operation (as all hoses are empty):

### Start the fuel pump

The external fuel pump can be started manual by an option in the xControl panel. See xControl manual for details. **Note:**



### Ventilation Screw

1. Open the ventilation screw located at the fuel solenoid valve. The „START“ button must continue to be pressed, whilst opening the screw. A large cloth or Kleenex tissue must be laid beneath the connection to prevent escaping fuel running into the capsule. If the fuel runs out without air bubbles, then the ventilation screw can be closed. Only then may the „START“ button be released.
2. Switch the panel „OFF“.

**This procedure must be repeated several times, until fuel (nonporously) withdraws perfectly at the ventilation screw.**

Fig. 7.11-1: Ventilation screw at the fuel solenoid valve

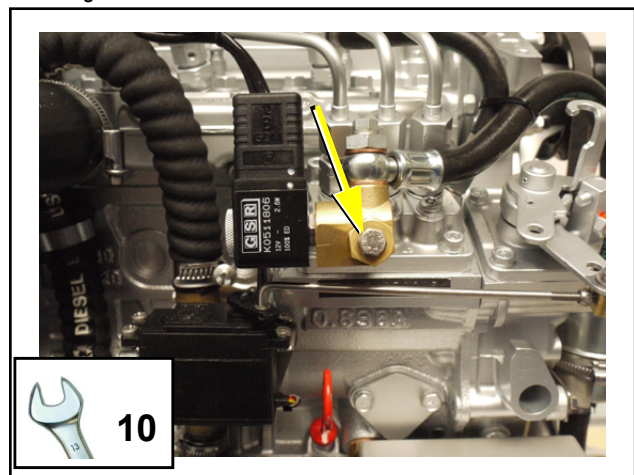

### Injection nozzles

3. Pressing the starter button can now start the machine. The machine should start after a short period.
4. If this does not occur, then a connecting nut fitted to the injection line must be loosened and starting procedure repeated. Retighten the washers after successfully starting. The injection line must be raised by several millimetres.
5. Switch main switch "OFF".

Fig. 7.11-2: Injection nozzles

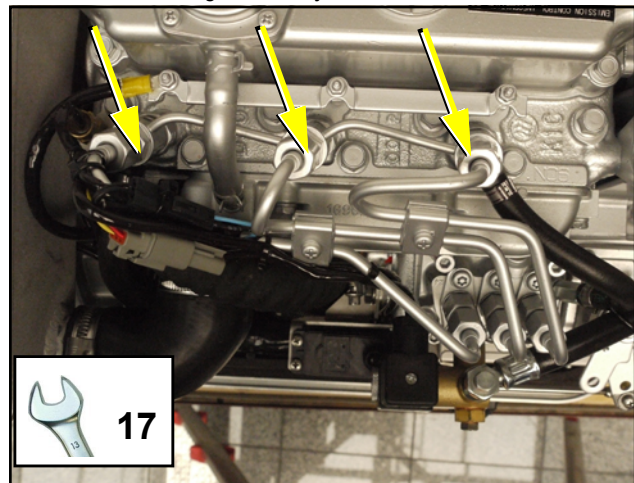

## 7.12 Replacement of the fuel filter

Exchanging the filter, depending upon fuel contamination, should take place after 300 operational hours at the very least. The inlet must be clamped, before exchanging the filter.

Remove the hoses from the used filter and fasten them to the new filter. The arrow on the filter housing indicates the direction of the fuel flow. A clogged filter causes a decreased power output of the generator.

Fig. 7.12-1: Fuel Filter



### 7.12.1 Optional fuel filter with sight glass

The filter change depends on the fuels' degree of pollution, but should be executed every 300 operating hours at the latest.

01. Fuel filter housing
02. Fuel filter element
03. Sight glass

Fig. 7.12.1-1: Fuel filter

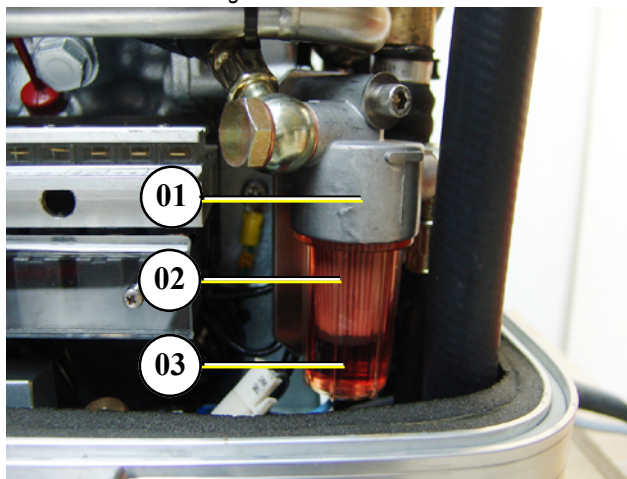

1. Unscrew the housing from its mount (left hand rotation).

Fig. 7.12.1-2: Fuel filter





2. Unscrew the filter element from the mount (left hand rotation).

Fig. 7.12.1-3: Fuel filter



3. Screw the new filter element into the mount.  
4. Lubricate the sight glasses o-ring with a heat resistant grease (Specification: Antiseize) and screw the sight glass back into its mount (right hand rotation).

Fig. 7.12.1-4: Fuel filter



## 7.13 Replacing the V-belt at Kubota 02/03/05 series

The described procedure is representative for Fischer Panda generators. The original location of the item must be taken from the generator description of this manual. All replacements and repairs should be done by a trained person.

**NOTE:Reprehensive procedure**



Due to the relatively high ambient temperature inside the closed sound insulation capsule (approx. 85 °C), the useful life of the V-belt is reduced. It is possible that the plasticisers in the rubber compounds may partially lose their effectiveness even after a short operating time because the air in the sound insulated capsule can be both relatively warm and dry.

The V-belt must therefore be checked at very short time intervals. It may be necessary to replace the V-belt after several weeks because of unfavourable conditions. A replacement interval of 250 operating hours must never be exceeded. The V-belt should be inspected after 50 operating hours. The V-belt must be considered a wearing part.

1. Loosen the fixing screw above the alternator.

Wrench with width across flats of 12 mm.



01. Fixing screw

Fig. 7.13-1: Alternator fixing screw

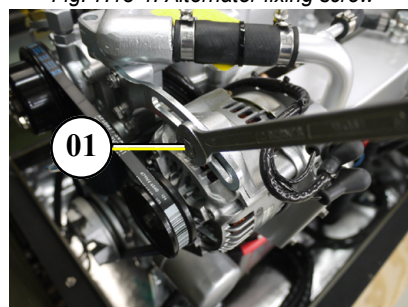

2. Loosen the fixing screw below the alternator.

Wrench with width across flats of 14 mm.



01. Fixing screw

Fig. 7.13-2: Alternator fixing screw

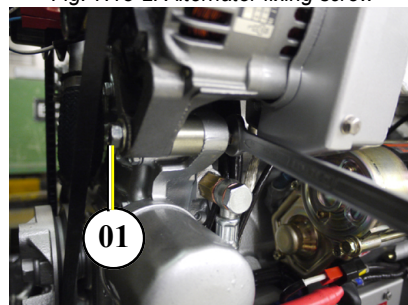

3. Push alternator towards the thermostat housing.

4. Replace the V-belt.

Fig. 7.13-3: Replacing the V-belt



5. The V-belt is tensioned by pulling back the alternator. The V-belt should yield approx. 1 cm when pushed in with a thumb.

Re-tighten the screws above and below the alternator.

Fig. 7.13-4: Replacing the V-belt

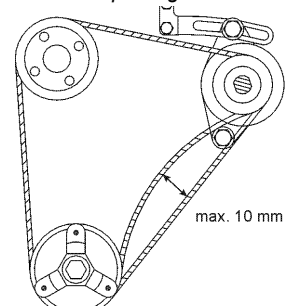



Leere Seite / Intentionally blank



## 8. Generator Failure

### 8.1 Personal requirements

---

The work described here, unless otherwise indicated, are performed by the operator.

More Repair work may be performed only by specially trained personnel or by authorized repair shops (Fischer Panda service points). This is especially for working on the valve timing, fuel injection system and the engine repair.

### 8.2 Hazard notes for the troubleshooting

---

**Follow the general safety instruction at the front of this manual.**

**Notice!**



**Danger for life! - The generator can be equipped with an automatic start device. This means the generator can be started by an external signal. To avoid an unexpected starting of the generator, the starter battery must be disconnected before start working at the generator.**

**Warning!: Automatic start**



**Working at a running generator can result in severe personal injury. Therefore before starting work at the generator:**

**Warning!: Risk of injury**



Make sure that the generator is stopped and the starter battery is disconnected to guarantee that the generator cannot be inadvertently started.

Do not run the generator with removed sound isolation cover.

**Improper installation/maintenance can result in severe personal injuries or material damage.**

**Warning!: Risk of injury**



- Always undertake installation/maintenance work when the generator is switched off.
- Ensure there is sufficient installation clearance before start working.
- Ensure tidiness and cleanliness at the workplace. Loose components and tools lying around or on top of each other are sources of accidents.
- Only perform installation work using commercially available tools and special tools. incorrect or damaged tools can result injuries.

**Oil and fuel vapours can ignite on contact with ignition sources. Therefore:**

**Warning!: Danger of fire**



- No open flames during work on the generator.
- Do not smoke.
- Remove oil and fuel residues from the generator and floor.



**Contact with engine oil, antifreeze and fuel can result in damage to health. Therefor:**

- Avoid skin contact with engine oil, fuel and antifreeze.
- Remove oil and fuel splashes and antifreeze from the skin immediately.
- Do not inhale oil and fuel vapours.

**Danger for Life. Improper handling, operation, installation and maintenance can result in severe personal injury and/or material damage.**

Electrical voltages above 56 volts (battery chargers greater than 48 volts) are always dangerous to life). The rules of the respective regional authority must be adhered to. Only an electrician may carry out installation of the electrical connections for safety reasons.

**Generator, oil and antifreeze can be hot during/after operation. Risk of severe burns.**

**During Installation/maintenance personal protective equipment is required to minimize the health hazards.**

- Protective clothing
- safety boots
- protective gloves
- Ear defender
- safety glasses

**Disconnect all load during the work at the generator to avoid damages at the load.**

**Danger!: Danger of poisoning**



**ATTENTION!: Danger to Life - High voltage**



**Warning!: Hot surface/material**



**Instructions!: Personal protective equipment necessary.**



**Attention!: Disconnect all load**





---

## 8.3 Tools and measuring instruments

---

**In order to be able to manage disturbances while driving, following tools and measuring instruments should belong to the equipment on board:**

- Multimeter for voltage (AC), frequency and resistance
- Measuring instrument for inductance
- Measuring instrument for capacity
- Current absorbing clamps
- Thermometer (ideal is a infrared thermometer)
- Pressure device (pincer) for coolant circuit

---

## 8.4 Overloading the Generator

---

Please ensure that the genset is not overloaded. This is especially the case with multi-power aggregates. Overloading occurs when the electrical load (demand) induces a load torque in the generator which is higher than what the diesel drive motor can provide. Overloading causes the engine to run rough, burn oil, create excessive exhaust (environmentally unfriendly) and even to stall.

The generator should only be loaded at high peak power for short periods only! A high peak current is required to start many electrical devices, especially electric motors and compressors (from a still stand state).

For a long engine life, the long term load should not exceed 80 % of the nominal load. Long term load is the load over several hours. It is harmless for the generator to deliver full nominal power for 2-3 hours.

The hole conception of the Fischer Panda generator make sure, that the full power operation at extreme condition will not increase the engine temperatures over. Please note that the emissions of the generator also increase at full power operation.

Bear this in mind when switching on electrical devices. This ensures a longer life expectancy.

---

### 8.4.1 Effects of Short Circuiting and Overloading on the Generator

---

The generator cannot be damaged by short circuiting or overloading. Short circuiting and overloading suppress the magnetic excitation of the generator, thus, no current is generated and the voltage will collapse. This condition is immediately offset once the short-circuit has been eliminated and/or the electrical overload removed.

---

### 8.4.2 Overloading the Generator with Electric Motors

---

Please note that electric motors require six to ten times more power than their rated capacity to start.

If the supplied generator power is lower than what the electric motor requires, the generator voltage will collapse. For applications where a high current draw is required to start an electrical device (such as an electric motor), the motor manufacturer should be consulted for possible solutions (for example: stronger capacitors, gradual power-up switches, or a specially designed starting unit for electric motors).

System efficiency can be improved by up to 50 % and motor current draw (to start) reduced by as much as 100 % if it is properly designed. If the inductive load (i.e. E-Motor) is more than 20 % of the generator nominal power, a compensation is necessary. See also the information brochure „Special information for operation of Panda generators with inductive load“.



### 8.4.3 Generator Voltage Fluctuations and Monitoring

---

**Before working (installation) on the System read the section Safety Instructions in this Manual.**

**Notice!:**



During periods of high electric loading, the voltage may drop to 190 V/50 Hz (or 95 V/60 Hz) or even lower. Such voltage drops can potentially cause damage to certain electrical devices such as electric motors, compressors and electronic equipment. In order to ensure that sufficient voltage is available and to avoid the risk of damage to sensitive electrical devices, the supply voltage should be monitored with the voltmeter, which is mounted at the operation unit.

The voltmeter must be respectively checked if additional load is switched on. As long as the voltage remains below the critical level the sensitive devices must be switched off during this period.

Over voltage can be caused by the generator under certain circumstances. This occurs, especially if the speed of the motor changes (increases in speed). Adjustment to the normal motor speed (rpm) should only be done with the use of a rev counter and/or a voltmeter.

A voltage regulated circuit breaker is installed in the electrical system in order to avoid damage, if sensitive or valuable equipment is used. (voltage control with circuit breaker).

### 8.4.4 Automatic Voltage Monitoring and Auto-Shut Down

---

If air conditioning units (compressors) or other such valuable equipment are installed on-board, an automatic voltage monitoring unit should be installed to protect this equipment from possible sharp voltage drops. The voltage monitoring system shuts down the entire system (and therefore all users) through a circuit breaker relay as soon as the voltage falls below a set value (the monitor will also shut down the on board grid automatically when the generator is stopped). The monitoring system also switches the grid back on once the required voltage level is again reached. This ensures no damage is caused to the load and fittings through under voltage. Such a voltage relay can be obtained from wholesale dealers or as a complete unit from PANDA dealers.

The circuit is always automatically cut off if the generator is stopped.

## 8.5 Low Generator-Output Voltage

---

---

If the produced alternating voltage is too low, switch the consumers off, in order to relieve the generator. Mostly the problem already solved. If the output voltage is still too low, even if all consumers are switched off, the generator runs without load, you can assume one or more condensers are defective.

### 8.5.1 Discharge the capacitors

---

Never work at the electrical cabinet, when the generator is running! Do not contact the capacitor. Before working on the system read the section "Safety Instructions - Safety First!" on page 15.

**ATTENTION!**



- 1) Switch off generator
- 2) Disconnect starter battery
- 3) Open AC-Control box



Fig. 8.5.1-1: Capacitor

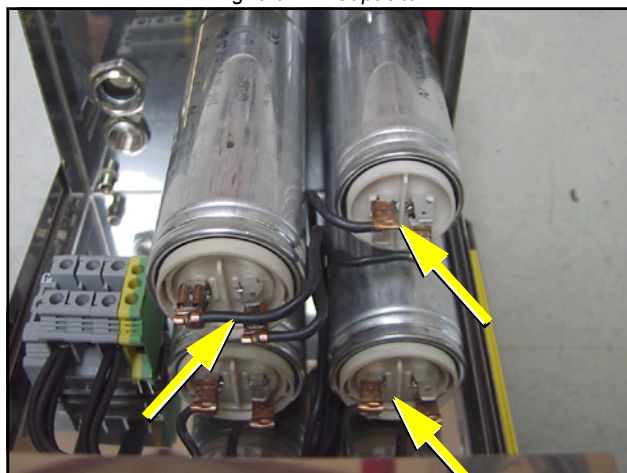

The capacitors are discharged, by short circuit the two contacts. In addition use the cone end of an isolated screwdriver.

## 8.5.2 Checking the Capacitors

Before working (installation) on the System read the section „Safety Instructions“ in this Manual.

**ATTENTION!**



Do not check the capacitors whilst the generator motor is running! Charged capacitors can be lethal. Do not contact the capacitors with bare fingers or non-insulated metallic objects! In order to test the capacitors, the terminal lead wires have to be disconnected using pliers or a screwdriver with insulated handle(s). Once the wires have been removed, the capacitors must be discharged by bridging the capacitor terminals together with a slot screwdriver with an isolated handle.

### Discharge the capacitor

1. Screw driver blade
2. Capacitor connections
3. Capacitor

Fig. 8.5.2-1: Capacitor

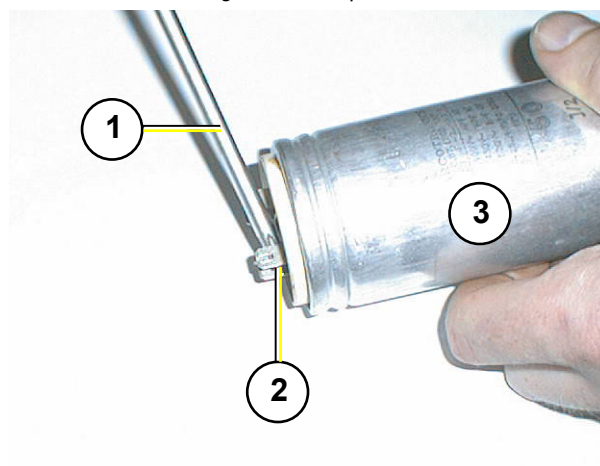

The capacitors can be checked using a normal multimeter with a continuity beeper. Check that the multimeter „beeps“ when the selector is set to continuity and the end probes are contacted together.



## Checking

Switch the multimeter to „Continuity: acoustic signal“ and touch both capacitor terminals with the meter end probes.

Fig. 8.5.2-2: Capacitor



Test each capacitor by touching the multimeter (set on „continuity“) end probes on the capacitor terminals: only a brief „beep“ should be audible from the multimeter.

Once this has been done, reverse the end probe positions and repeat the check. (The multimeter battery charges the capacitor and then the capacitor discharges quickly. The discharge to the multimeter „closes“ the circuit briefly and continuity is achieved for a brief instant causing the short „beep“.)

If there is no beep at all or there is a continuous beep, then the capacitor(s) is faulty and needs to be replaced.

Inductance is measured in the same way as the ohmic resistance, i.e. the coils are compared. The value is indicated in mH (milli Henry).

The arranging value for the inductive resistance can take from the Table 12.4, „Technical data coil,“ on Page 132.

Note: These values depends strongly from the measuring method (kind of the measuring instrument)



---

## 8.6 Testing generator stator windings

---

### 8.6.1 Checking the generator voltage

---

In order to test, whether the fixed winding produces enough voltage, proceed in such a way:

1. Guarantee that the connection to the electrical system is interrupted.
2. Remove all conductions in the power terminal box of the generator.
3. Starter battery must be connected with the generator.
4. Start the generator start.
5. Measure with a voltmeter the voltage between the phase(s) and N. If the measured values are under the substantially values in Table 12.4-5, "Voltage values stator coil," on Page 133, a coil damage is to be accepted.

During the measurement in the 60 Hz version both partial coils must be interconnected, i.e. a connection must be provided between line 1 and line 3. (see wiring diagram)

*(notes: the voltage results from the remainder magnetism of the rotor, which induced a voltage in the coil.)*

### 8.6.2 Measuring the coil resistance

---

**For this a measuring instrument must be used that is suitable for low impedance values.**

- Adjust the measuring instrument to resistance test. If hold the poles of the measuring instrument hold together, 0.00 ohms should be indicated. If the poles are isolated, the display should indicate an overflow. Please implement this test, in order to examine the equipment.
- Measure of the resistance within the individual windings.

If strong deviations in the individual coils are measured, must assumed that there is a coil short-circuit in a coil. This leads to the fact that the generator does not excite itself any longer.

The actual values between the coils and ground are not to be determined exactly. It depends primarily on the fact that the values of all three measurements are close to the same. Deviations among themselves refer to a coil short-circuit. In this case the generator must be wound again by a specialist.

### 8.6.3 Checking the coil(s) to short-circuit

---

In order to check the coils for short-circuit, first all lines, which lead to the electrical system, must be interrupted. This happens on the power terminal box of the generator or, if available, in the electrical system junction box. Guarantee that no voltage lies at the lines, before they are interrupted (see "Discharge the capacitors" on Page 122.).

Now remove the bridge between „N“ and „PE“, so that coils and housing are electrically separate from each other.

Check with a circuit indicator (multimeter) in the power terminal box if between the individual connection points of the coil and the housing (PE) a pass exists.



The contacts which can be measured depend on the type of the generator (see identification plate):

HP1 - 50 Hz: L, Z

HP1 - 60 Hz: L, Z

HP3 - 50 Hz: L1, L2, L3

HP3 - 60 Hz: L1, L2, L3, 1, 2, 3, 4

DVS - 50 Hz: L1, L2, L3, L1'

DVS - 60 Hz: L1, L2, L3, L1', 1, 2, 3, 4

Fig. 8.6.3-1: Type plate

FischerPanda		S/No	
Typ		Year	
Mod.		Weight	
Art. No.		T <sub>amb max</sub>	
Y		P <sub>n</sub>	
U <sub>n</sub>		S <sub>n</sub>	
f <sub>n</sub>		Cos φ	
I <sub>n</sub>		P <sub>con</sub>	
Fischer Panda GmbH Otto-Hahn-Str. 40 33104 Paderborn Germany Made in Germany www.fischerpanda.de		CE	

If a pass (beep) should be determined, the generator must be returned for examination in the plant, or it can also be wound again locally. For this coil data can be requested.

### 8.6.4 Measuring the inductive resistance

Unfortunately the checking of the ohmic resistance permits still no reliable statement about the condition of the coil. If the ohmic resistance values arise inequalities between the coils, that is a safe indication for the fact that the coil is defective. To be exactly sure the inductive resistance of the coil have to be measured. For this a special measuring instrument is necessary, which measures the inductance of a coil.

### 8.6.5 Testing generator stator winding for „shorts“ to ground

If no faults are found with the capacitors and the generator is still not performing correctly, the generator stator windings must be tested for „shorts“ to ground as follows:

1. Ensure that the generator is „OFF“ and cannot be accidentally started. Disconnect the battery.
2. Remove AC output terminal box lid (mounted on generator casing).
3. All terminal box connections are to be removed. (See appropriate circuit diagram.)
4. Remove all cables (also earth lead).
5. A check of the generator terminal box is made by means of a multimeter to determine whether there is continuity between the individual windings connections and ground.

If continuity is detected for any of the combinations, the generator must be sent to the factory for inspection and repair. If this is not possible, the stator can be rewound by a qualified trades person/technician. Winding diagrams can be obtained from Fischer Panda GmbH, Germany.

This test, unfortunately, is carried out at very low voltage (9 V) when a normal multimeter is used. Therefore only positive short circuits will be displayed. There is the possibility that a short circuit will occur in spite of a negative test result (i.e. moisture). A reliable check can only be carried by using an essentially higher voltage (approx 500 V). This type of measuring instrument is normally only used by experts.

If in doubt an electrician must check the winding for a short circuit with an isolation meter.

### Generator Power Terminal Box 230 V / 50 Hz

In these terminal box there are the electrical connection points for the AC generator. Here is also the bridge for the protective grounding of the generator. The cover may only be removed, if it is guaranteed that the generator cannot be inadvertently started.

*representative picture*

Fig. 8.6.5-1: Generator output terminal box 230 V / 50 Hz

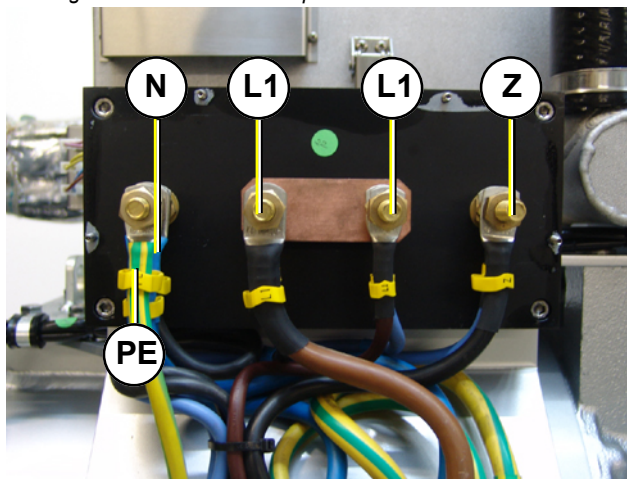
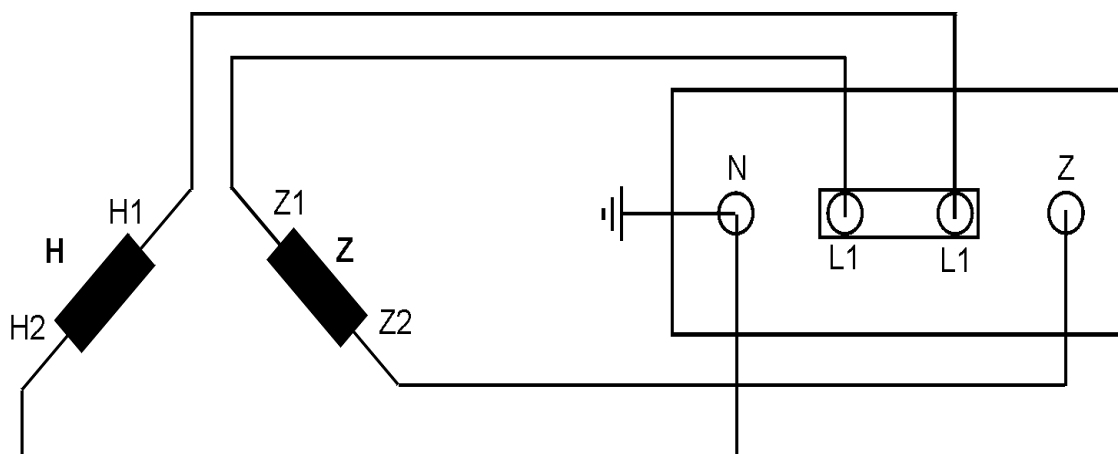

Fig. 8.6.5-2: Wiring diagram HP1 - 230 V / 50 Hz



### Generator Power Terminal Box 400 V / 50 Hz

In these terminal box there are the electrical connection points for the AC generator. Here is also the bridge for the protective grounding of the generator. The cover may only be removed, if it is guaranteed that the generator cannot be inadvertently started.

*representative picture*

Fig. 8.6.5-3: Generator Power Terminal Box 400 V / 50 Hz

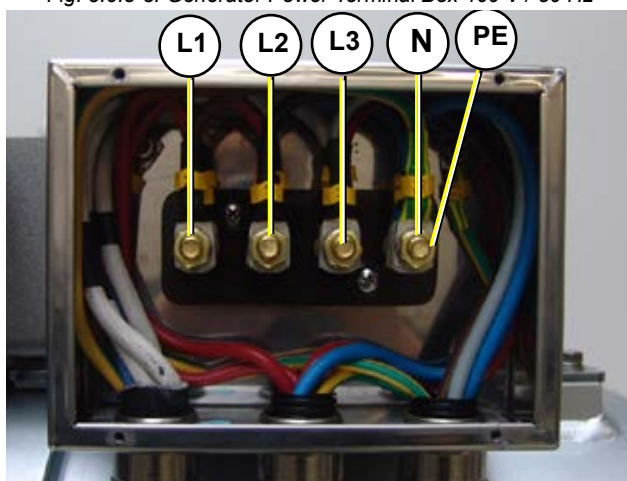
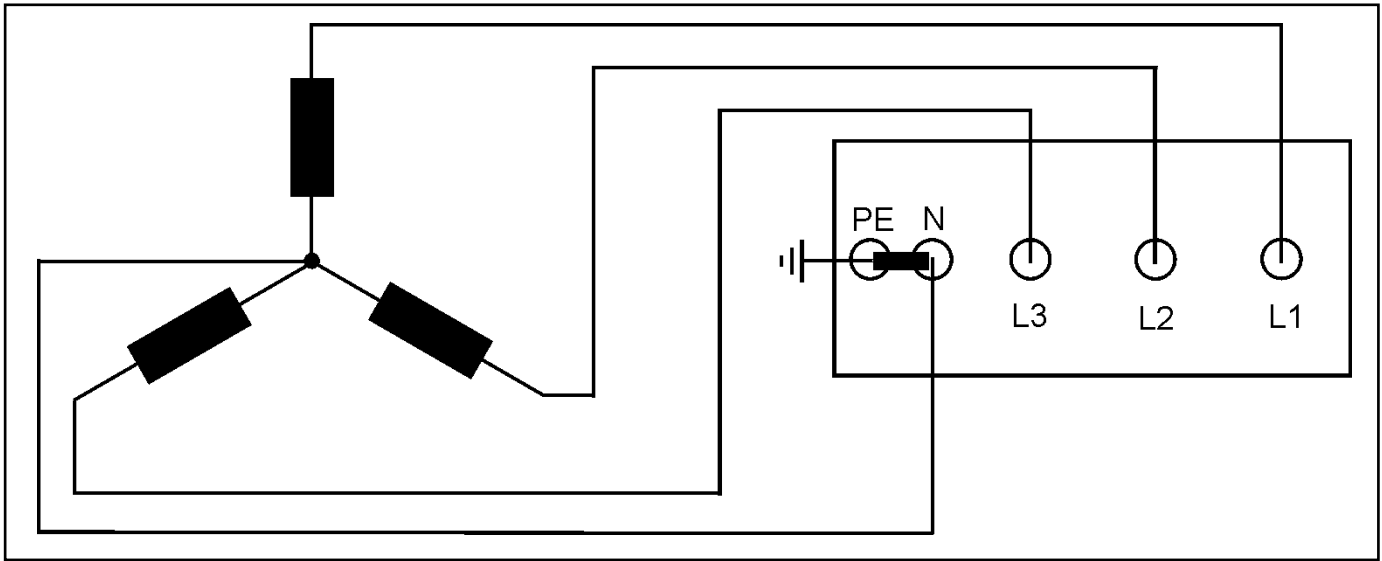



Fig. 8.6.5-4: Wiring diagram HP3 - 400 V / 50 Hz





### Generator Power Terminal Box 120 V / 60 Hz

In these terminal box there are the electrical connection points for the AC generator. Here is also the bridge for the protective grounding of the generator. The cover may only be removed, if it is guaranteed that the generator cannot be inadvertently started.

representative picture

Fig. 8.6.5-5: Generator power terminal box 120 V / 60 Hz

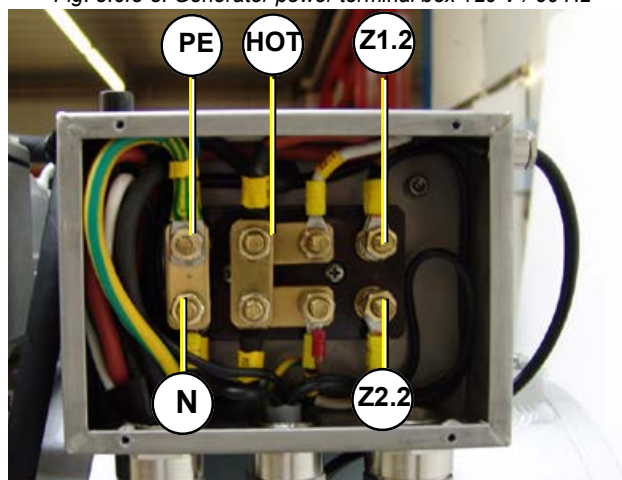
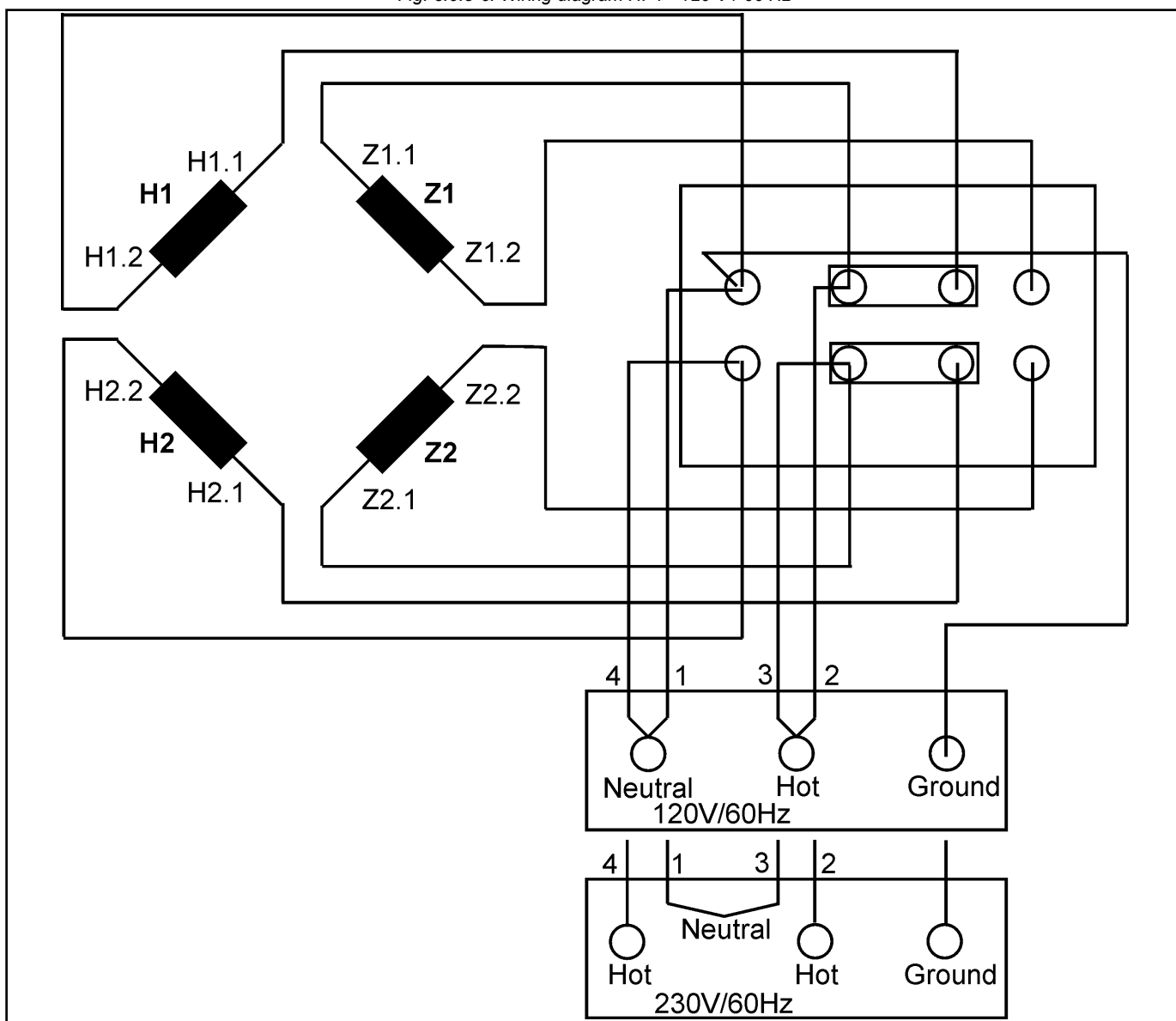

Fig. 8.6.5-6: Wiring diagram HP1 - 120 V / 60 Hz





### Generator Power Terminal Box 240 V / 60 Hz (208 V / 60 Hz)

In these terminal box there are the electrical connection points for the AC generator. Here is also the bridge for the protective grounding of the generator. The cover may only be removed, if it is guaranteed that the generator cannot be inadvertently started.

*representative picture*

Fig. 8.6.5-7: Generator power terminal box 240 V / 60 Hz

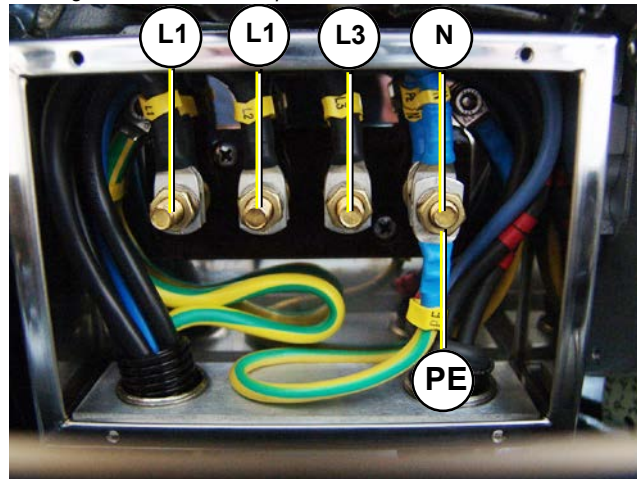
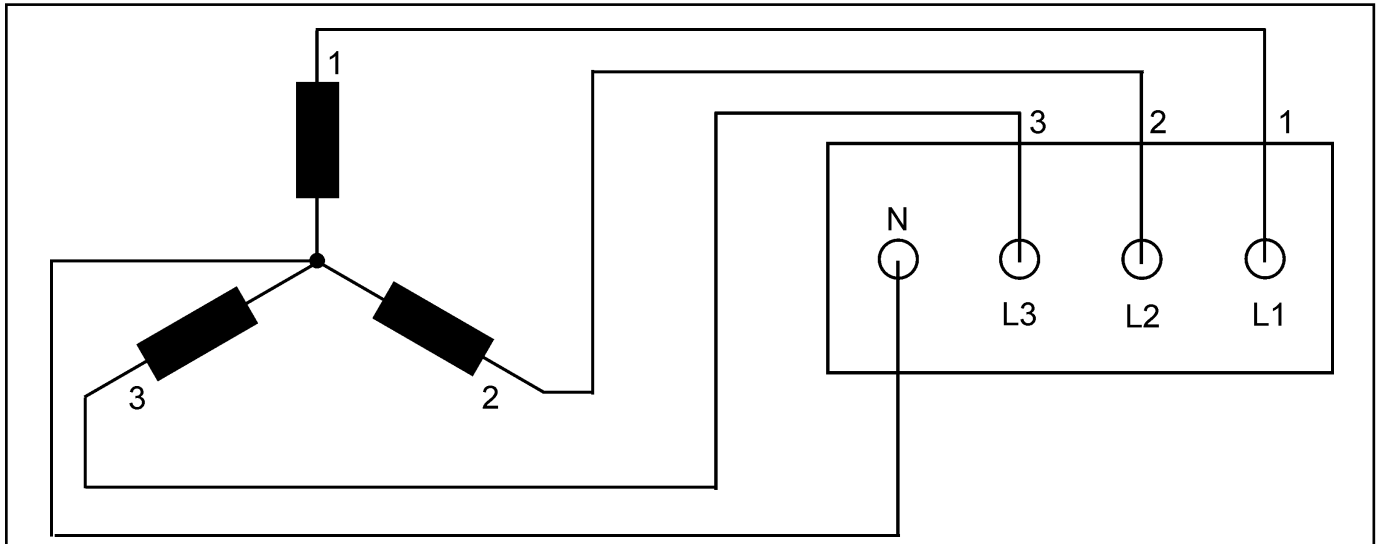

Fig. 8.6.5-8: Wiring diagram HP3 - 240 V / 60 Hz





### Generator Power Terminal Box DVS - 120 V + 240 V / 60 Hz

In these terminal box there are the electrical connection points for the AC generator. Here is also the bridge for the protective grounding of the generator. The cover may only be removed, if it is guaranteed that the generator cannot be inadvertently started.

*representative picture*

Fig. 8.6.5-9: Generator power terminal box DVS

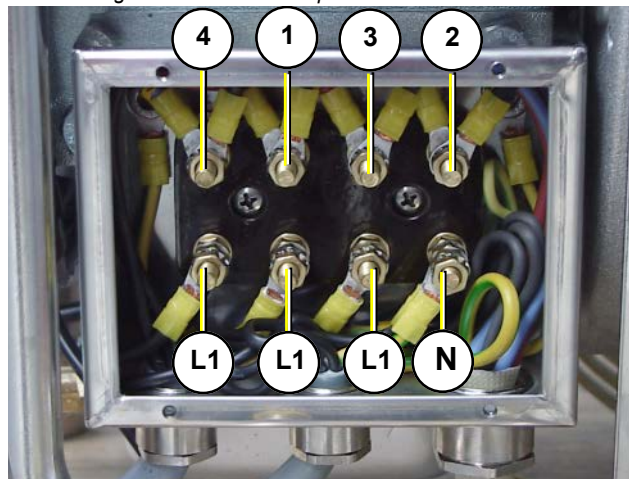

Fig. 8.6.5-10: Wiring diagram DVS - 120 V + 240 V / 60 Hz

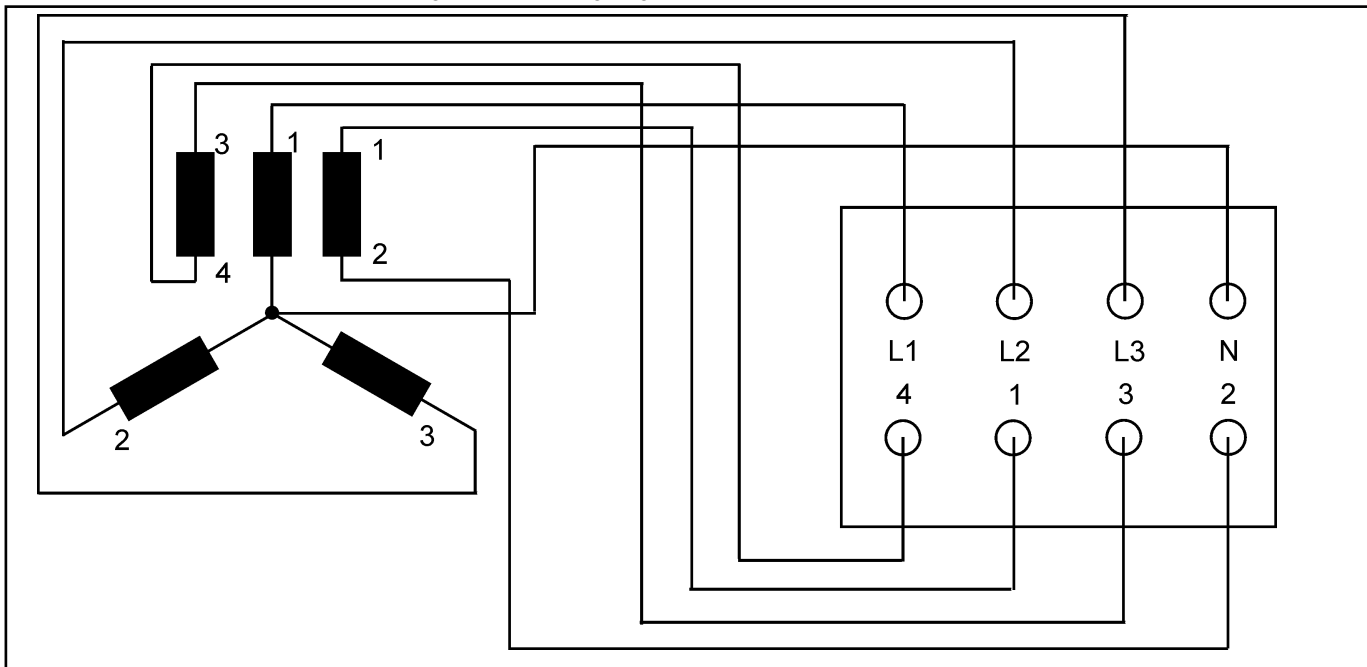
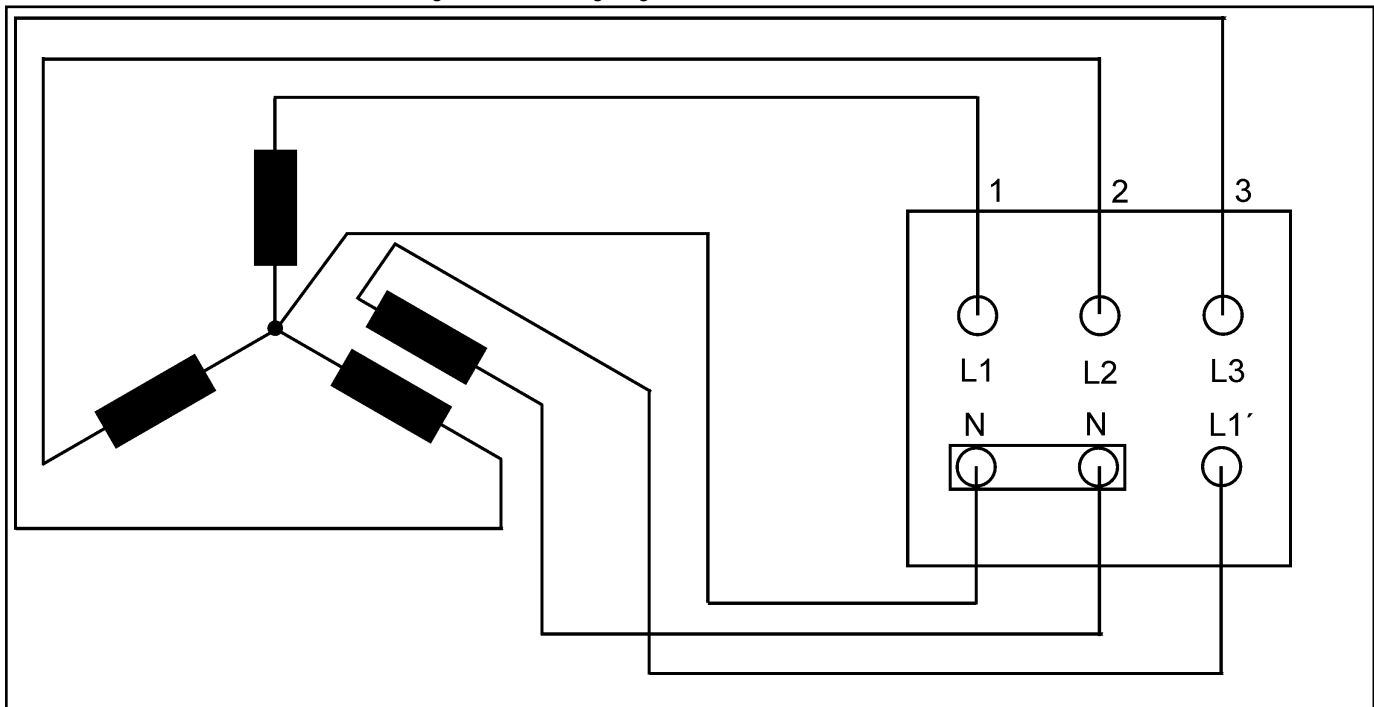



Fig. 8.6.5-11: Wiring diagram DVS - 230 V + 400 V / 50 Hz



## 8.6.6 Coil Resistance Measurements in Stator Windings

When there are neither faults with the capacitors nor any low or high voltage „shorts“ in the windings to ground, the windings should then be tested for the correct coils resistance (for shorts between wires within the coils). To measure coil resistance a meter capable of measuring low resistances (Milli-Ohm resolution if possible) accurately.

### 8.6.6.1 Checking windings.

- Disconnect all the cables from the terminals in the AC-connection box.
- Remove the Neutral- Ground connection.
- Take all the winding connection cables from the terminal bolts.
- Switch your meter in resistance range. When you put the probes of you meter together, you should get a reading of 0.00 Ohm. When you isolate the probes, the reading will be Overflow. Please do this tests to check your meter.
- Measure the resistance between the separate windings. Maybe the readings of your meter do not comply with the values of the table in the appendix. In every case the relation between the values should be the same. Some meters do not work fine, when values are very small.
- Measure the resistance between the different windings. When you find a value in the 20 Mega- Giga Ohm range, the winding is ok.
- Measure the resistance between the different windings and housing of the alternator. Here you should also find a value in the Giga-Ohm range. When the winding is shorted to ground, maybe you are not able to measure this, because the voltage of your meter is a few volts. In this case to get a save reading, use a MEGA-meter with a high test voltage

If you find any abnormality, when doing this test, please ask your Fischer Panda dealer.

If the measured resistance values deviate from each other significantly, then there is probably a short within the coils. A short within the coils can prevent the generator from achieving the required excitation and therefore from reaching the rated power output. The values listed in the above table, represent the approximate range of acceptable resistances. Most important is that the measures values do not deviate significantly from one another. Large resistance value deviations between phases indicate a short-circuit in the windings. In this case the generator must be newly wound by a qualified technician.



## 8.7 Measuring the Coil Inductive Resistance

---

Unfortunately a reliable assessment of the winding's performance cannot be attained through checking only coil resistances. However, the symmetry of the coil resistances is a good indicator of winding performance. If the coil resistances are symmetric, the next step is to measure the winding's inductive resistance using a special meter (capable of measuring milli-Henrys).

The coil induction is measured and compared in the same manner as the electrical resistance (i.e. the windings are compared for symmetry). These parts must have the same values.

Note: These values strongly depend on the method of measurement (e.g. used instruments)

**An alternative test method to check the stator windings can be performed as follows:**

1. Ensure that the connection to the circuit system is disconnected.
2. All electrical wires in the generator terminal box must be disconnected.
3. Reconnect the battery connections.
4. Start the generator.
5. Measure the voltages between the following terminals and compare for symmetry: L1-N, L1-Z.

## 8.8 Generator provides no Voltage

---

### 8.8.1 Rotor Magnetism Loss and „Re-magnetizing“

---

After having stood idle for a longer period of time, or after having been shut down abruptly from operating under a heavy electrical load, most asynchronous generators have difficulties achieving full excitation independently. The remaining rotor magnetism is lost.

**Before working on the System read the section „Safety Instructions“ in this Manual. Notice!:**



The magnetism required for excitation can be easily restored using a simple DC Battery. The generator must be stopped to do this, that means the starter may not be actuated. DC is fed to a desired part of the winding from the exterior for a short period. This can, for example, be carried out for by feeding DC to the windings from both terminals of a 230 V (115 V) socket of the vehicles system. (This, of course, can only happen if there is no connection to any power source). There must be a connection between socket and the generator (see diagram below). It suffices if DC is applied for a short period (1-2 seconds). The remaining magnetism can be restored and the generator can be started in the normal manner again.

**Before this procedure is performed to restore the magnetic field, it is crucial to ensure that the generator is not running! (otherwise, it is very DANGEROUS TO LIFE!)**

**ATTENTION!**





Fig. 8.8.1-1: Generator termination box

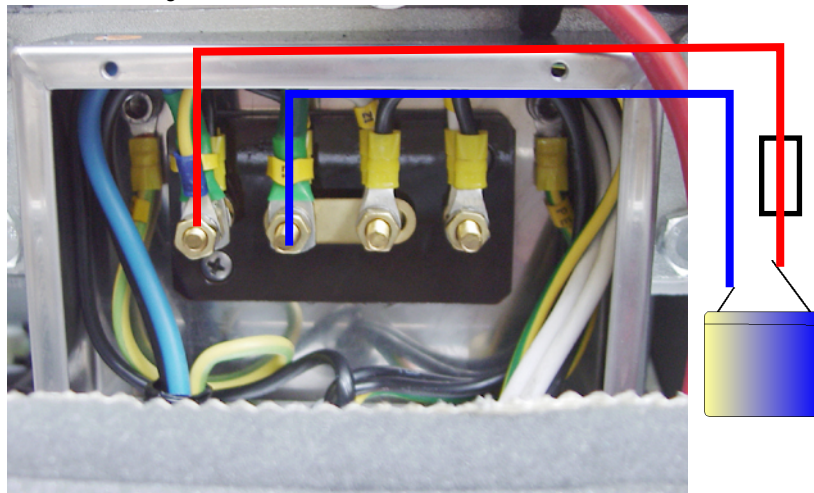

Initializing the magnetic field in the windings through external current from a 4,5 - 9 volt battery. (No car-battery!)

## 8.8.2 Stop solenoid

There are two different variations:

### A. Energized to stop

By pressing the „OFF“-button on the remote control panel the stop solenoid is supplied with voltage and operate, through this the injection nozzles resets to zero position and the generator stops.

### B. Energized to run

This version is equipped with two solenoids an actuating and a stop solenoid. After being fed with current, the actuating solenoid attracts the adjusting lever of the fuel injection pump, through which the fuel can flow. The actuating solenoid is switched off once the final position has been reached, which is maintained by the stop solenoid for as long as the generator is running

**When starting the „START“-button may not be pressed longer than 5 sec., because the stop solenoid pulls too much current over the starter. Otherwise the stop solenoid must be disconnected.**

**.Notice!:**



### Stop solenoid (optional)

Fig. 8.8.2-1: Stop solenoid

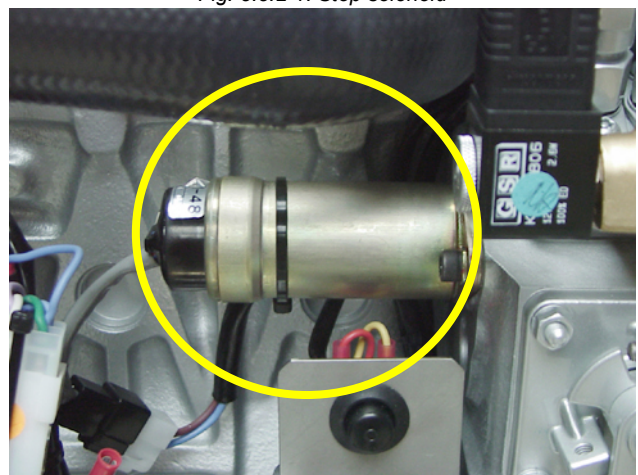



---

### 8.8.3 Damage to starter motor

---

The starter is fitted with a free wheel or axial rotating spring cog, which prevents the starter being driven externally by means of the motor. The free wheel will be heavily worn, if the starter still operates, thereby causing damage to the springs, roller bearings or cog teeth. This could lead to complete destruction of the starter.

**It is important that every person who operates the generator is informed of this situation. This is practically the only handling error that can be made on board that can lead to fatal consequences for both generator and operator.**



## 8.9 Troubleshooting Table

### 8.9.1 Generator faults

#### 8.9.1.1 Generator output too low. For 50 Hz versions: less than 200 V. For 60 Hz versions: less than 100 V.

Cause	Solution
Generator is overloaded.	Reduce the electrical load. (Switch off load)
Motor is not reaching the rated rpm.	Refer to „motor faults“ section.
Defective capacitor(s).	Check capacitors and replace if necessary.

#### 8.9.1.2 Generator voltage too high (more than 240 V-50 Hz / 135 V-60 Hz). If the generator is providing excessively high voltage, the following potential causes should be investigated:

Cause	Solution
Over-energizing due to wrong capacitors.	Check capacitors type and replace if necessary.

#### 8.9.1.3 Generator voltage fluctuates.

Cause	Solution
1. Disturbances on the electrical system/user side.	1. Check if electrical load is fluctuating.
2. Motor disturbances.	2. Refer to section: „Motor runs irregular“.

#### 8.9.1.4 Generator is not able to start an electric motor.

Cause	Solution
If the generator is unable to supply enough power to start an electric motor (120V-60Hz or 231V-50Hz), it is usually because the motor draws too much current during the starting process.	Check the motor's current draw required for starting (switch to 380V if possible). This could be remedied by providing stronger capacitors or installing an optional „Easy Start Booster Set“. (See Apt. G) Enquire at your nearest Panda dealer or directly at the manufacturer.

#### 8.9.1.5 Diesel motor fails to start

Cause	Solution
Starter battery switched „OFF“.	Check position of battery switch and switch „ON“ (if installed).
Starter battery voltage insufficient (battery too weak).	Inspect battery terminals and cables for a good electrical connection (Inspect against corrosion, tattered wires, etc.).
Starting current disrupted.	During the normal starting process, the battery voltage drops to 11V with a fully charged battery. If the voltage does not drop during starting, the electrical connection is faulty. If the battery voltage drops lower than 11V, then the battery has been discharged.



### 8.9.1.6 Starter motor is turning the engine, but generator fails to start.

Cause	Solution
Fuel inlet solenoid valve not opening.	Check wire connections and circuitry to solenoid valve. (ref. DC wiring diagram: Relay K2, Fuse)
Fuel pump not working.	Check fuel-filter and pump: clean if necessary.
Lack of fuel.	Check fuel supply.
Glow-plugs not working correctly.	Check glow plugs and heating time.
Too much air in fuel lines.	Test fuel system for leakage. Bleed air from fuel system (refer to section „Bleeding Air from Fuel System“).
Fuel-filter blocked.	Replace fuel filter.
Low compression pressure.	See motor-manual.

### 8.9.1.7 Motor does not achieves enough speed during starting process.

Cause	Solution
Starter battery voltage insufficient.	Check battery.
Damaged bearing(s) piston (seized).	Repairs need to be carried out by engine manufacturer-Service. (refer to motor-manual)
Cooling water in combustion chamber.	<ol style="list-style-type: none"><li>1. Turn generator „OFF“ at control panel.</li><li>2. Remove the glow plug (see engine-manual).</li><li>3. Rotate the motor by hand carefully.</li><li>4. Check if there is water in the oil and change both oil and filter if necessary.</li><li>5. Determine cause for excess water in the combustion chamber. The excess water can be caused by a defective air vent in the cooling water system, which should be checked and cleaned, or replaced if faulty.</li></ol>

### 8.9.1.8 Motor runs irregular

Cause	Solution
Faulty centrifugal injector governor.	Have the centrifugal governor inspected by a motor manufacturer-Service technician.
Too much air in fuel lines.	Bleed air from fuel system.

### 8.9.1.9 Motor speed drops.

Cause	Solution
Lack of fuel	Check fuel supply system: - fuel filter, renew if necessary - check fuel pump - check fuel lines (bleed if necessary)
Lack of intake air.	Check air intake paths. Check and clean air filter (and intake muffler if installed).
Generator overloaded by too many load.	Reduce the electrical load (switch off load).
Generator overloaded by over-energizing.	Check that the proper capacitor type is installed and that they are connected correctly.
Defective generator (windings, bearings, or other).	Generator must be sent to manufacturer for repair of damaged bearings or winding.
Damaged engine.	Repair of bearing damage, etc., by motor manufacturer-Service.



### 8.9.1.10 Motor runs in off position.

Cause	Solution
Fuel inlet solenoid valve or throttle shut solenoid is not switching off.	Check wire connections to solenoid. Check valve functions as in the „Inlet Fuel Solenoid Valve“ or in the truckle shut off solenoid sections. Replace if necessary.

### 8.9.1.11 Motor stops by itself.

Cause	Solution
Lack of fuel.	Check fuel supply system.
Excess heat in cooling system (thermo switch tripped)-lack of cooling water. Is indicated on the remote control panel.	Check cooling water system flow: water pump, inlet water filter, extra heat exchanger coolant flow.
Lack of oil pressure sensor tripped). Is indicated on the remote control panel.	Check oil-level and if necessary top up. Check motor's oil-pressure and have repaired by motor manufacturer-Service if necessary.
Over-/under voltage. Is indicated on the remote control panel.	Switch-off the remote control panel, reduce the electrical load (switch-off load), start again.

### 8.9.1.12 Sooty black exhaust.

Cause	Solution
Generator is overloaded.	Check electrical load and switch off unnecessary load.
Insufficient intake air.	Check intake air filter; clean if necessary.
Fuel injector faulty.	Replace injector.
Valve clearance incorrect.	Readjust valve clearance to correct value (refer to motor-manual).
Poor fuel quality.	Use better quality diesel (recommended: 2-D Diesel).
Poor combustion.	Incorrect AFR (air/fuel ratio) due to motor timing adjustment. Have motor serviced by manufacturer.
Low compression pressure.	See motor-manual.

### 8.9.1.13 Generator must be shut off immediately if:

Cause	Solution
<ul style="list-style-type: none"><li>- motor rpm suddenly rises or drops</li><li>- unusual noise comes from genset</li><li>- exhaust colour suddenly becomes dark</li><li>- leakage in the cooling water system.</li></ul>	Refer to respective section of manual and if necessary, have repaired by motor manufacturer-Service, or Panda representative.



## 9. Appendix

### 9.1 Engine oil

#### 9.1.1 Engine oil classification

The quality of an engine oil is specified by the API standard („American Petroleum Institutes“). The API designation is to be found on each engine oil bundle. The first letter is always a C.

See technical data for the specified engine oil

Notice!



Fig. 9.1.1-1: Engine oil type.

Engine oil type	
over 25 °C	SAE10W-40; SAE 15W-40;SAE 20W-50
0 °C to 25 °C	SAE10W-40
below 0 °C	SAE10W-40;SAE 5W-40

### 9.2 Coolant specification

Use a mixture of water and antifreeze. The antifreeze needs to be suitable for aluminium. The antifreeze concentration must be regularly checked in the interests of safety.

Fischer Panda recommend to use the product: GLYSANTIN PROTECT PLUS/G 48

Engine coolant automotive industry Product description		
Product name	GLYSANTIN ® PROTECT PLUS / G48	
Chemical nature	Monoethylenglycol with inhibitors	
Physical form	Liquid	
Chemical and physical properties		
Reserve alkalinity of 10ml	ASTM D 1121	13 – 15 ml HCl 01 mol/l
Density, 20 °C	DIN 51 757 procedure 4	1,121 – 1,123 g/cm <sup>3</sup>
Water content	DIN 51 777 part 1	max. 3,5 %
pH-value undiluted		7,1 – 7,3



## 9.2.1 Coolant mixture ratio

Water/antifreeze	Temperature
70:30	-20 °C
65:35	-25 °C
60:40	-30 °C
55:45	-35 °C
50:50	-40 °C

## 9.3 Fuel

Use a clean Diesel fuel oil according to DIN590:1999 or better. For Generators with common rail or particle filter use DIN590:2009 or better.

Do not use alternative fuel, because its quality is unknown or it may be inferior in quality. Kerosene, which is very low in cetane rating, adversely affects the engine.

## 9.4 Technical data coil

Data for generators not mentioned on request.

Notice!



Fig. 9.4-1: Resistor generator coil HP1

	L-N [Ohm]	L-Z [Ohm]
<b>Mains</b>	<b>120V / 60Hz</b>	
Panda 8000	approx. 0,7	approx. 0,7
Panda 9000	approx. 0,65	approx. 0,65
Panda 12000	approx. 0,45	approx. 0,45
Panda 18	approx. 0,2	approx. 0,2
Panda 24	approx. 0,06	approx. 0,06
<b>Mains:</b>	<b>230V / 50Hz</b>	
Panda 8000	approx. 0,9	approx. 0,9
Panda 9000	approx. 0,8	approx. 0,8
Panda 12000	approx. 0,3	approx. 0,3
Panda 14000	approx. 0,25	approx. 0,25
Panda 18	approx. 0,25	approx. 0,25
Panda 24	approx. 0,17	approx. 0,17
Panda 30	approx. 0,1	approx. 0,1

Fig. 9.4-2: Inductance generator coil HP1

	L-N [Ohm]	L-Z [Ohm]
<b>Mains</b>	<b>120V / 60Hz</b>	
Panda 8000	approx. 2,8	approx. 2,8
Panda 9000	approx. 2,8	approx. 2,8
Panda 12000	approx. 3,5	approx. 3,5
Panda 18	approx. 3,2	approx. 3,2
Panda 24	approx. 0,3	approx. 0,3
<b>Mains</b>	<b>230V / 50Hz</b>	
Panda 8000	approx. 3,7	approx. 3,7
Panda 9000	approx. 3,7	approx. 3,7
Panda 12000	approx. 3,5	approx. 3,5
Panda 14000	approx. 2,3	approx. 2,3
Panda 18	approx. 1,8	approx. 1,8
Panda 24	approx. 1,3	approx. 1,3
Panda 30	approx. 0,9	approx. 0,9

Fig. 9.4-3: Resistor generator coil DVS

	L1-N [Ohm]	L2-N [Ohm]	L3-N [Ohm]	L1'-N [Ohm]	1-2[Ohm]	3-4[Ohm]
<b>Mains</b>	<b>120V / 60Hz</b>					
Panda 8000	approx. 0,7	approx. 0,7	approx. 0,7	approx. 0,15	approx. 0,15	
Panda 9000	approx. 0,65	approx. 0,65	approx. 0,65	approx. 0,17	approx. 0,17	
Panda 12000	approx. 0,45	approx. 0,45	approx. 0,45	approx. 0,15	approx. 0,15	
Panda 18	approx. 0,2	approx. 0,2	approx. 0,2	approx. 0,05	approx. 0,05	
Panda 24	approx. 0,06	approx. 0,06	approx. 0,06			
<b>Mains:</b>	<b>230V / 50Hz</b>					



	L1-N [Ohm]	L2-N [Ohm]	L3-N [Ohm]	L1'-N [Ohm]	1-2[Ohm]	3-4[Ohm]
Panda 8000	approx. 0,9		approx. 0,9		approx. 0,9	approx. 0,4
Panda 9000	approx. 0,8		approx. 0,8		approx. 0,8	approx. 0,4
Panda 12000	approx. 0,3		approx. 0,3		approx. 0,3	approx. 0,2
Panda 14000	approx. 0,25	approx. 0,25	approx. 0,25	approx. 0,12		
Panda 18	approx. 0,25	approx. 0,25	approx. 0,25	approx. 0,1		
Panda 24	approx. 0,17	approx. 0,17	approx. 0,17	approx. 0,1		
Panda 30	approx. 0,1	approx. 0,1	approx. 0,1	approx. 0,08		

Fig. 9.4-4: Inductance generator coil DVS

	L1-N [mH]	L2-N [mH]	L3-N [mH]	L1'-N [mH]	1-2[mH]	3-4[mH]
<b>Mains</b>	<b>120V / 60Hz</b>					
Panda 8000	approx. 2,8	approx. 2,8	approx. 2,8	approx. 0,8	approx. 0,8	
Panda 9000	approx. 2,8	approx. 2,8	approx. 2,8		approx. 0,9	approx. 0,9
Panda 12000	approx. 3,5	approx. 3,5	approx. 3,5	approx 1,0	approx. 1,0	
Panda 18	approx. 3,2	approx. 3,2	approx. 3,2		approx. 0,4	approx. 0,4
Panda 24	approx. 0,3	approx. 0,3	approx. 0,3			
<b>Mains:</b>	<b>230V / 50Hz</b>					
Panda 8000	approx. 3,7	approx. 3,7	approx. 3,7	approx. 2,3		
Panda 9000	approx. 3,7	approx. 3,7	approx. 3,7	approx. 2,3		
Panda 12000	approx. 3,5	approx. 3,5	approx. 3,5	approx. 2,3		
Panda 14000	approx. 2,3	approx. 2,3	approx. 2,3	approx. 1,5		
Panda 18	approx. 1,8	approx. 1,8	approx. 1,8	approx. 1,1		
Panda 24	approx. 1,3	approx. 1,3	approx. 1,3	approx. 0,8		
Panda 30	approx. 0,9	approx. 0,9	approx. 0,9	approx. 0,6		

Fig. 9.4-5: Voltage values stator coil

Terminal	Panda 8000	Panda 9000	Panda 12000	Panda 14000	Panda 18	Panda 24	Panda 30
L1 - L2	3-5 Volt	4-6 Volt	5-7 Volt	6-9 Volt	6-10 Volt	6-11 Volt	7-12 Volt
L2 - L3	3-5 Volt	4-6 Volt	5-7 Volt	6-9 Volt	6-10 Volt	6-11 Volt	7-12 Volt
L3 - L1	3-5 Volt	4-6 Volt	5-7 Volt	6-9 Volt	6-10 Volt	6-11 Volt	7-12 Volt
L1' - N (50Hz)	~ 2-3 Volt	~ 2-3 Volt	~ 3-4 Volt	~ 3-5 Volt	~ 3-5 Volt	~ 3-5 Volt	~ 3-6 Volt
4 - 2 (60Hz)	~ 2-3 Volt	~ 2-3 Volt	~ 3-4 Volt		~ 3-5 Volt	~ 3-5 Volt	

Fig. 9.4-6: Voltage values stator coil

Terminal	Panda 8000	Panda 9000	Panda 12000	Panda 14000	Panda 18	Panda 24	Panda 30
L - N	~ 2-3 Volt	~ 2-3 Volt	~ 3-4 Volt	~ 3-5 Volt	~ 3-5 Volt	~ 3-5 Volt	~ 3-6 Volt
4 - 2 (60Hz)	~ 2-3 Volt	~ 2-3 Volt	~ 3-4 Volt		~ 3-5 Volt	~ 3-5 Volt	

## 9.5 Cable cross-section

Fig. 9.5-1: Cable cross-section

Voltage	Required cable cross-section						
	< 6 kW	6-10 kW	10-15 kW	15-20 kW	20-35 kW	35-45 kW	45-65 kW
120V 1-ph.+PEN	4x6mm <sup>2</sup>	4x10mm <sup>2</sup>	4x16mm <sup>2</sup>	4x25mm <sup>2</sup>	4x35mm <sup>2</sup>	4x50mm <sup>2</sup>	4x70mm <sup>2</sup>
230V 1-ph.+PEN	2x4mm <sup>2</sup>	2x6mm <sup>2</sup>	2x10mm <sup>2</sup>	2x16mm <sup>2</sup>	2x25mm <sup>2</sup>	2x35mm <sup>2</sup>	2x35mm <sup>2</sup>
400V 3-ph.+PEN	4x2,5mm <sup>2</sup>	4x4mm <sup>2</sup>	4x6mm <sup>2</sup>	4x10mm <sup>2</sup>	4x16mm <sup>2</sup>	4x16mm <sup>2</sup>	4x25mm <sup>2</sup>



## 9.6 Technical data

Fig. 9.6-1: Technical data

	Panda 4000s Panda 4,5ND	Panda 4200 FCB	4500FCB	Panda 4k Panda 5k	Panda 5000 LPE
Type	Farymann 18W430	Farymann 18W430	Farymann 18W430	Z482	EA300
Governor	mechanic	mechanic	mechanic	mechanic VCS	VCS
Automatic start booster	yes	yes	yes	no	no
Cylinder	1	1	1	2	1
Bore	82 mm	82 mm	82 mm	67 mm	75 mm
Stroke	55 mm	55 mm	55 mm	68 mm	70 mm
Stroke volume	290 cm <sup>3</sup>	290 cm <sup>3</sup>	290 cm <sup>3</sup>	479 cm <sup>3</sup>	309 cm <sup>3</sup>
Max. power (DIN 6271-NB) at 3000 rpm	5,7 kW	5,7 kW	5,7 kW	9,32 kW	5,1 kW
Rated speed	3600 rpm	3600 rpm	3600 rpm	3000 rpm	3000 rpm
Idle running speed <sup>2</sup>	3690 rpm	3690 rpm	3690 rpm	3120 rpm	2900 rpm
Valve clearance (engine cold)	0,2 mm	0,2 mm	0,2 mm	0,2 mm	0,16 - 0,20 mm
Cylinder head nut torque	30-33 Nm	30-33 Nm	30-33 Nm	42 Nm	58,8 - 63,7 Nm
Compression ratio	20:1	20:1	20:1	23:1	--
Lubrication oil capacity	1,25 l	1,25 l	1,25 l	2,8 l	1,3 l
Fuel consumption <sup>3</sup>	approx 0,42- 1,12 l	approx. 0,42- 1,12 l	approx. 0,42- 1,12 l	approx. 0,5-1,4 l	approx. 0,42 - 1,12 l
Oil consumption	max. 1 % of fuel consumption				
Oil specification	API CF	API CF	API CF	API CF	API CF
Cooling water requirement for seawater circuit (Marine generators only)	10-12 l/min	10-12 l/min	16-28 l/min	16-28 l/min	--
Permissible max. permanent tilt of engine	a) 25° across the longitudinal axis b) 20° in the longitudinal direction				
Recommend starter battery size	12 V 28 Ah equivalent	12 V 28 Ah equivalent	12 V 36 Ah equivalent	12 V 28 Ah equivalent	12 V 28 Ah equivalent
Recommend cable cross size starter battery cable Length 4 meter max.	25 mm <sup>2</sup>	25 mm <sup>2</sup>	25 mm <sup>2</sup>	25 mm <sup>2</sup>	25 mm <sup>2</sup>
Max. exhaust back pressure	9,3 kPa 93 Millibar	9,3 kPa 93 Millibar <sup>2</sup>	9,3 kPa 93 Millibar	9,3 kPa 93 Millibar	--

<sup>2</sup> progressive speed by VCS

<sup>3</sup> 0,35 l/kW electrical power, the randomized values between 30 % and 80 % of the rated speed

Fig. 9.6-2: Technical data

	Panda 6500 Panda 7 mini	Panda 8000 Panda 8 mini	Panda 9000	Panda 10000 Panda 9 mini	Panda 12000
Type	Z482	Z482	D722	Z602	D722
Governor	MIni VCS	VCS	mechanic	VCS	VCS
Automatic start booster	no	yes	no	yes	yes
Cylinder	2	2	3	2	3
Bore	67 mm	67 mm	67 mm	72 mm	67 mm
Stroke	68 mm	68 mm	68 mm	73,6 mm	68 mm
Stroke volume	479 cm <sup>3</sup>	479 cm <sup>3</sup>	719 cm <sup>3</sup>	599 cm <sup>3</sup>	719 cm <sup>3</sup>
Max. power (DIN 6271-NB) at 3000 rpm	9,32 kW	9,32 kW	14,0 kW	11,6 kW	14,0 kW
Rated speed	3000 rpm	3000 rpm	3000 rpm	3000 rpm	3000 rpm
Idle running speed <sup>2</sup>	3120 rpm	2900 rpm	3120 rpm	3100 rpm	2900 rpm



	Panda 6500 Panda 7 mini	Panda 8000 Panda 8 mini	Panda 9000	Panda 10000 Panda 9 mini	Panda 12000
Valve clearance (engine cold)	0,2 mm	0,2 mm	0,2 mm	0,2 mm	0,2 mm
Cylinder head nut torque	42 Nm	42 Nm	42 Nm	42 Nm	42 Nm
Compression ratio	23:1	23:1	23:1	24:1	23:1
Lubrication oil capacity	2,8 l	2,8 l	3,8 l	2,8 l	3,8 l
Fuel consumption <sup>3</sup>	approx. 0,5-1,4 l	approx. 0,7-1,8 l	approx. 0,8-2,1 l	approx. 1,0-2,66 l	approx. 1,1-2,8 l
Oil consumption	max. 1 % of fuel consumption				
Oil specification	API CF	API CF	API CF	API CF	API CF
Cooling water requirement for seawater circuit (Marine generators only)	16-28 l/min	16-28 l/min	16-28 l/min	16-28 l/min	16-28 l/min
Permissible max. permanent tilt of engine	a) 25° across the longitudinal axis b) 20° in the longitudinal direction				
Recommend starter battery size	12 V 28 Ah equivalent	12 V 28 Ah equivalent	12 V 36 Ah equivalent	12 V 36 Ah equivalent	12 V 36 Ah equivalent
Recommend cable cross size starter battery cable <i>Length 4 meter max.</i>	25 mm <sup>2</sup>	25 mm <sup>2</sup>	25 mm <sup>2</sup>	25 mm <sup>2</sup>	25 mm <sup>2</sup>
Max. exhaust back pressure	9,3 kPa 93 Millibar	9,3 kPa 93 Millibar <sup>2</sup>	9,3 kPa 93 Millibar	9,3 kPa 93 Millibar	9,3 kPa 93 Millibar

<sup>2</sup> progressive speed by VCS

<sup>3</sup> 0,35 l/kW electrical power, the randomized values between 30 % and 80 % of the rated speed

Fig. 9.6-3: Technical data

	Panda 12000	Panda 15000 15 mini digital	Panda 18	Panda 24	Panda 30
Type	Mitsubishi MVL3E	D902	D1105	V1505	V1505 TD
Governor	xContol Servo	VCS	VCS	VCS	VCS
Automatic start booster	yes	yes	yes	no	no
Cylinder	3	3	3	4	4TD
Bore	76 mm	72 mm	78 mm	78 mm	78 mm
Stroke	70 mm	73,6 mm	78,4 mm	78,4 mm	78,4 mm
Stroke volume	952 cm <sup>3</sup>	898 cm <sup>3</sup>	1123 cm <sup>3</sup>	1498 cm <sup>3</sup>	1498 cm <sup>3</sup>
Max. power (DIN 6271-NB) at 3000 rpm		17,5 kW	18,7 kW	23,3 kW	31,3 kW
Rated speed		3000 rpm	3000 rpm	3000 rpm	3000 rpm
Idle running speed <sup>2</sup>		2900 rpm	2900 rpm	2900 rpm	2900 rpm
Valve clearance (engine cold)		0,2 mm	0,2 mm	0,2 mm	0,2 mm
Cylinder head nut torque		42 mm	68 Nm	68 Nm	68 Nm
Compression ratio	23:1	24:1	22:1	22:1	23:1
Lubrication oil capacity	3,6 l	3,7 l	5,1 l	6,0 l	6,7 l
Fuel consumption <sup>3</sup>	approx. 1,1-2,8 l	approx. 1,3-3,6 l	approx. 1,7-4,5 l	approx. 2,2-5,9 l	approx. 2,7-7,2 l
Oil consumption	max. 1 % of fuel consumption				
Oil specification	API CF-4	API CF	API CF	API CF	API CF
Cooling water requirement for seawater circuit (Marine generators only)	16-28 l/min	16-28 l/min	28-40 l/min	28-40 l/min	40-50 l/min
Permissible max. permanent tilt of engine	a) 25° crosswise to the longitudinal axis b) 20° in longitudinal direction				
Recommend starter battery size	12 V 36 Ah equivalent	12 V 52 Ah equivalent	12 V 65 Ah equivalent	12 V 70 Ah equivalent	12 V 70 Ah equivalent
Recommend cable cross size starter battery cable <i>Length 4 meter max.</i>	25 mm <sup>2</sup>	25 mm <sup>2</sup>	25 mm <sup>2</sup>	25 mm <sup>2</sup>	25 mm <sup>2</sup>
Max. exhaust back pressure		9,3 kPa 93 Millibar <sup>2</sup>	10,7 kPa 107 Millibar	10,7 kPa 107 Millibar	10,7 kPa 107 Millibar



<sup>2</sup> progressive speed by VCS

<sup>3</sup> 0,35 l/kW electrical power, the randomized values between 30 % and 80 % of the rated speed

Fig. 9.6-4: Technical data

	Panda 30 IC	Panda 40 LN	Panda 47 LN	Panda 60 MB	Panda 75 MB
<b>Type</b>	Kubota V 1505 TB	LDW 2204 MT	LDW 2204T	Mercedes Benz OM602	Mercedes OM603A
<b>Governor</b>	VCS	VCS	VCS	mechanic + VCS	mechanic + VCS
<b>Automatic start booster</b>	yes	no	no	no	no
<b>Cylinder</b>	4	4	4	5	6
<b>Bore</b>	78 mm	88 mm	88 mm	89 mm	89 mm
<b>Stroke</b>	78,4 mm	90,4 mm	90,4 mm	92,4 mm	92,4 mm
<b>Stroke volume</b>	1498 cm <sup>3</sup>	2199 cm <sup>3</sup>	2199 cm <sup>3</sup>	2874 cm <sup>3</sup>	3500 cm <sup>3</sup>
<b>Max. power (DIN 6271-NB) at 3000 rpm</b>	31,3 kW	36 kW	36 kW	69 kW	69 kW
<b>Rated speed</b>	3000 rpm	3000 rpm	3000 rpm	4000 rpm	3000 rpm
<b>Idle running speed <sup>2</sup></b>	2900 rpm	3000 rpm	3000 rpm		2900 rpm
<b>Valve clearance (engine cold)</b>	0,2 mm	Hydro	Hydro		0,2 mm
<b>Cylinder head nut torque</b>	63,7 - 68,6 Nm	68 Nm	68 Nm		25 Nm
<b>Compression ratio</b>	22,5:1	22:16	22:16		22:1
<b>Lubrication oil capacity</b>	6,0 l	6,4 l	6,4 l	7,5 l	7,5 l
<b>Fuel consumption <sup>3</sup></b>	approx. 2,7 - 7,1 l	approx. 4,9-13,1 l	approx. 3,78-10,1 l	approx. 6,3 - 16,8 l	approx. 6,7 - 17,9 l
<b>Oil consumption</b>	max. 1 % of fuel consumption			max. 0,5 % of fuel consumption	
<b>Oil specification</b>	API CF	API CF	API CF-4	API CF	API CF
<b>Cooling water requirement for seawater circuit (Marine generators only)</b>	40-50 l/min	40-50 l/min	40-50 l/min		
<b>Permissible max. permanent tilt of engine</b>	a) 25° crosswise to the longitudinal axis b) 20° in longitudinal direction				
<b>Recommend starter battery size</b>	12 V 70 Ah equivalent	12 V 88 Ah equivalent	12 V 88 Ah equivalent	12 V 95 Ah equivalent	12 V 95 Ah equivalent
<b>Recommend cable cross size starter battery cable</b> <i>Length 4 meter max.</i>	25 mm <sup>2</sup>	50 mm <sup>2</sup>	50 mm <sup>2</sup>	70 mm <sup>2</sup>	70 mm <sup>2</sup>
<b>Max. exhaust back pressure</b>	10,7 kPa 107 Millibar	10 kPa 100 Millibar	10 kPa 100 Millibar		

<sup>2</sup> progressive speed by VCS

<sup>3</sup> 0,35 l/kW electrical power, the randomized values between 30 % and 80 % of the rated speed

<sup>2</sup> progressive speed by VCS

<sup>3</sup> 0,35 l/kW electrical power, the randomized values between 30 % and 80 % of the rated speed



# Fischer Panda



## Panda xControl Manual



## Current revision status

	Document
<b>Current:</b>	Panda_xControl_eng.R03_10.3.26
<b>Replaces:</b>	Panda_xControl_eng.R02

Revision	Page
Manual compiled on the basis of deu R02	
R03 new design	

### Created by

Fischer Panda GmbH - Head of Technical Documentation

Otto-Hahn-Str. 40

33104 Paderborn - Germany

Phone: +49 (0) 5254-9202-0

E-mail: [info@fischerpanda.de](mailto:info@fischerpanda.de)

web: [www.fischerpanda.de](http://www.fischerpanda.de)

### Copyright

Reproduction of and changes to the manual are permitted only by agreement and with the permission of the manufacturer!

Fischer Panda GmbH, 33104 Paderborn, reserves all rights regarding text and graphics in this document. Details are given to the best of our knowledge. No liability is accepted for correctness. Please note: technical modifications aimed at improving the product may be implemented without prior notice. Therefore, it must be ensured prior to installation that the pictures, diagrams, and related material are applicable to the equipment supplied. In case of doubt, verify upon delivery that documentation and equipment match.



# 10. Panda xControl Safety Instructions

## 10.1 Personnel

---

The settings described here can be performed by the operator unless highlighted differently.

The installation should be implemented by specially trained technical personnel or by authorised workshops (Fischer Panda Service Points), only.

## 10.2 Safety instructions

---

**Adhere to the safety instructions in the Fischer Panda generator manual.**

*If these instructions are not to hand, they can be requested from Fischer Panda GmbH, 33104 Paderborn, Germany.*

**Note!**



**An external signal may trigger an automatic start-up.**

**WARNING: Automatic start-up**



**The generator must not be operated with the cover removed.**

**Warning!**



If the generator is being installed without a sound insulation capsule, it must be ensured that all rotating parts (belt pulley, belts etc.) are covered and protected so that there is no danger to life and body!

All service, maintenance, or repair work may only be carried out when the unit is not running.

**Electric voltage - Deadly Danger!**

**WARNING: Electrical voltage**

Electric voltages of more than 48 V are potentially lethal in any situation. The rules of the respective regional authority must be adhered to for installation and maintenance.



For safety reasons, only an electrician may carry out the installation of the electrical connections of the generator.

**Disconnect battery before working on the generator**

**Attention!**

The battery must always be disconnected (first the negative terminal, then the positive terminal) if work on the generator or electrical system is to be performed, so that the generator cannot be started inadvertently.



This applies in particular to systems with an automatic start-up function. The automatic start-up function shall be deactivated before starting work.

*The flooding valve must be closed. (For PMS version only.)*



---

**Also observe the safety instructions for the other components of your system.**

**Note!**





# 11. Panda xControl

The Panda xControl is a generator control system with three main components.

## 11.1 Components of the xControl

---

### 11.1.1 xControl - CP-G

---

(Control Panel – Generator) - Part No. 21.02.02.204P

#### Display and Control Element of the xControl

The xControl CP-G is the display and control element

Power is supplied via the bus cable. Multiple control elements can be installed in a single system.

Fig. 11.1.1-1: Control Panel - Generator



### 11.1.2 xControl - GC-S

---

(Generator Control - Servo) - Part.No. 21.02.08.019P

#### Main module of the xControl.

#### The module contains the control electronics

The xControl GC-S is usually installed in the generator capsule.

The xControl GC-S takes over the monitoring and control of the diesel engine of the Fischer Panda generator, as well as the control of the output voltage and frequency of the generator.

Fig. 11.1.2-1: Generator Control - Servo



The xControl GC-S is suitable for 12 V and 24 V starting systems. The connected actuators are supplied with power via switching outputs with input voltage.

*Current measurement is single-phase and can be done directly. A voltage sensor is not necessary. Current measurement takes place via an external current sensor. An additional three-phase module can be used for three-phase generators.*

### 11.1.3 xControl - CB-G

---

(Connection Box - Generator)

#### The xControl GC-S is usually installed in the generator capsule (externally).

The xControl CB-G is the external terminal block for the xControl generator.

The control element and the fuel pump are connected here.

Fig. 11.1.3-1: Connection Box - Generator





An emergency stop device, auto-start, load relays and boosters can be connected as options.

**Only electricians may work on the xControl CB-G**

**Note:**



## 11.2 Installation

### 11.2.1 Installation of the Electronic Control Unit (ECU) xControl - GC-S

The ECU xControl - GC-S is pre-installed. The ECU can be exchanged easily. All connections are mechanically coded and prevent the risk of confusion.

### 11.2.2 Installation of the Connection Box xControl - CB-G

The connection box is pre-installed. External components are connected in accordance with the installation manual and the circuit diagram of the xControl generator.

### 11.2.3 Installation of the xControl - CP-G

The xControl - CP-G is a CAN Bus module. All Fischer Panda CAN bus modules have two RJ45 ports. One for connection to the module on the CAN bus, the second to relay the CAN bus. The last module on the CAN bus must have a terminating resistor in the RJ45 port.

Connection by means of the Fischer Panda bus cable is mandatory.

Fig. 11.2-1: xControl CP-G rear

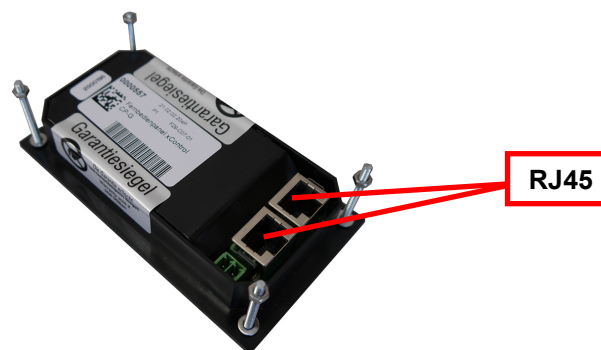
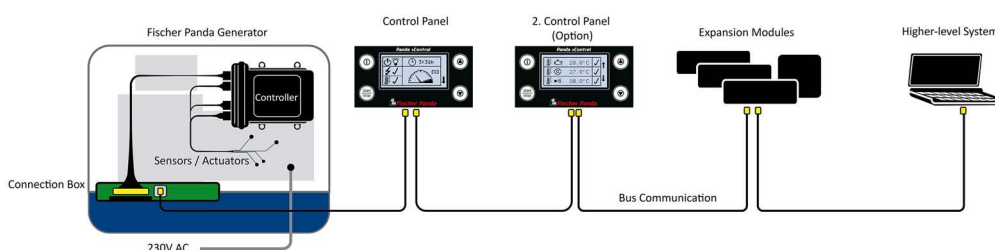

Fig. 11.2-2: Connection Diagram





## 11.3 Operation

The xControl is operated by means of the xControl CP-G panel.

Fig. 11.3-1: xControl CP-G front



### 11.3.1 Switching on the generator

Press the "ON/OFF" switch to switch on the control system of the generator.

The xControl Generator thereby switches to "standby mode".

If automatic starting is activated at the menu, the generator can henceforth be started by means of an external signal.

Fig. 11.3.1-1: Switching on the generator

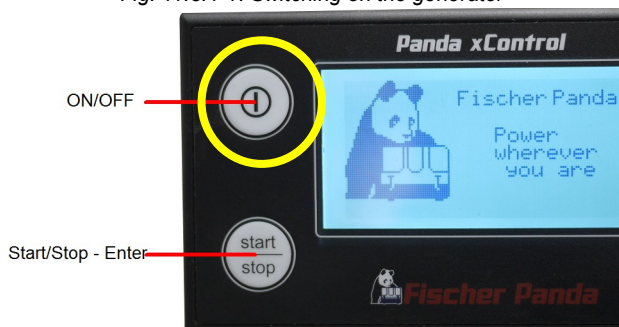

The CP-G Panel displays the home page for two seconds.

Fig. 11.3.1-2: Home Page

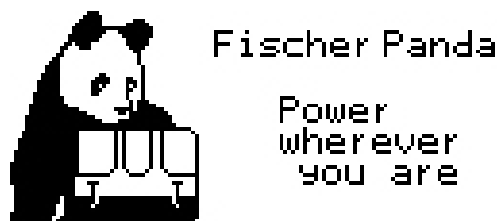

The CP-G then displays the address page for one second

Fig. 11.3.1-3: Address Page

```
addr.: 7
vers.: V3rff
serial: 00000.00177
-----
addr.: 15
vers.: V4r27
serial: 00000.00013
```



At the end of the power-on routine, the CP-G displays the first overview page.

The language as well as the display mode can be set in the menu.

Overview Page 1 is the same in all display modes/languages.

Fig. 11.3.1-4: Overview Page 1

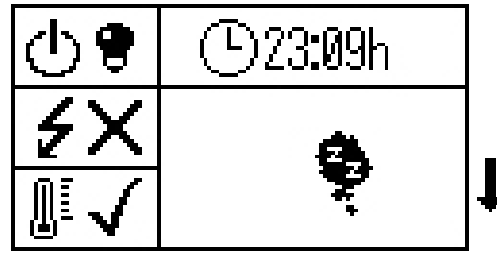

### 11.3.1.1 Overview page with Autostart activated

**Deadly danger! - The generator can be equipped with an Autostart function. This means that the generator is started by an external signal. In order to prevent an inadvertent start-up, the starter battery must be disconnected before work on the generator may commence.**

**WARNING: Autostart**



**The "Autostart" also remains active if the xControl CP-G is switched off and then on again.**

If a fault should arise when the generator is started or is already operating, it is stopped and the Autostart is set to "off".

If the generator is operated by Autostart and is stopped manually, the Autostart is set to "off".

Once the system has been switched off and then on again, the Autostart is active once more.

**The first overview page shows if the Autostart is active.**

Fig. 11.3.1-1: Overview Page 1 with Autostart

Overview Page 1 with Autostart function activated.



### 11.3.2 The overview pages

The display mode/language of the display can be set in the menu.

### 11.3.3 Symbols used in overview pages

#### Overview Page 1:

- 01. Generator Status (on/off)
- 02. AC OK
- 03. Temperature of the generator (OK/Error)
- 04. Operating hours of the generator
- 05. Info screen

Overview Page 1 is the same in all languages.

#### Overview Page 2 (Generator):

- 06. Output voltage [V]
- 07. Generator current [A]
- 08. Generator apparent power [kVA]

Fig. 11.3.3-1: Symbols used in Overview Page 1

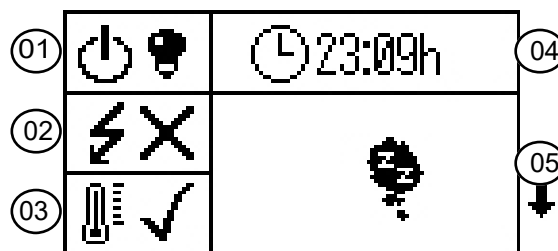
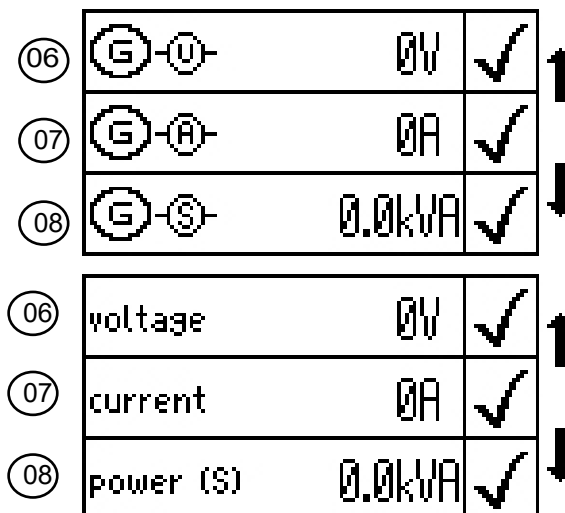

Fig. 11.3.3-2: Overview Page 2 Symbols/English



In the case of three-phase generators, the voltage, the current and the electrical power are shown on separate pages. Each page shows the value of the three phases one below the other.

**Example of the voltage display of a 3-phase generator.**

Note:



Fig. 11.3.3-3: Voltage display 3-P Symbols/English

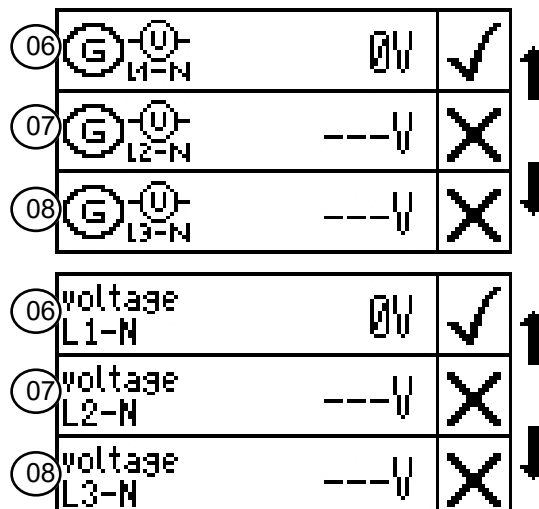



**Overview Page 3:**

- 09. Frequency of the generator [Hz]
- 10. Generator speed (r.p.m.)
- 11. Voltage of the starter battery [V]

Fig. 11.3.3-4: Overview Page 3 Symbols/English

09		0.0Hz	✓	↑ ↓
10		0rpm	✓	
11		13.2V	✓	
09	frequency	0.0Hz	✓	↑ ↓
10	rotational speed	0rpm	✓	
11	bat.-volt.	13.1V	✓	

**Overview Page 4:**

- 12. Temperature of the cylinder head
- 13. Temperature of the generator winding
- 14. Temperature at exhaust manifold

Fig. 11.3.3-5: Overview Page 4 Symbols/English

12		---°C	✗	↑ ↓
13		---°C	✗	
14		---°C	✗	
12	engine temperature	---°C	✗	↑ ↓
13	winding temperature	---°C	✗	
14	exhaust temperature	---°C	✗	

If the information pages of optional components (e.g. fuel gauge, oil pressure) are available, then these pages are inserted after Overview Page 4.

Whether these pages are displayed automatically, always or not at all can be set in the Panel menu.

**Final Overview Page:**

Proceed to this menu by pressing the Start/Stop - Enter key

Overview Page 5 is the same in all display modes/languages.

**Note!:**



Fig. 11.3.3-6: Final overview page





---

## 11.4 Starting up the generator

---

### 11.4.1 Preparations for starting up / Checks (daily) for marine version

---

1. Oil level check (ideal level: 2/3 Max).  
The level should be about 2/3 of the maximum level when the engine is cold.  
Further, if installed, the oil level of the oil-cooled bearing must be checked before each start - see sight glass on generator front cover!.
2. Check cooling water level.  
The external expansion tank should be filled to 1/3 in a cold state. It is very important that there is sufficient volume for expansion of the coolant.
3. Check if the raw water intake valve is open.  
For safety reasons, the raw water intake valve must be shut after the generator has been switched off. It should be re-opened before starting the generator.
4. Check raw water filter.  
The raw water filter must be regularly checked and cleaned. If the raw water intake is restricted by detached residue, this increases wear on the impeller.
5. Visual inspection  
Control fixing bolts, check hose connectors for leaks, check electrical connections. Check electrical lines for damage/chafing.
6. Switch off loads.  
The generator should only be started without a load.
7. Open fuel valve, if installed.
8. Close main battery switch (switch on).

### 11.4.2 Preparations for starting up / Checks (daily) for vehicle version

---

1. Oil level check (ideal level: 2/3 Max).  
The level should be about 2/3 of the maximum level when the engine is cold.  
Further, if installed, the oil level of the oil-cooled bearing must be checked before each start - see sight glass on generator front cover!.
2. Check cooling water level.  
The external expansion tank should be at 1/3 in a cold state. It is very important that there is sufficient volume available for expansion of the coolant.
3. Visual inspection  
Control fixing bolts, check hose connectors for leaks, check electrical connections. Check electrical lines for damage/chafing.
4. Switch off loads.  
The generator should only be started without a load.
5. Open fuel valve, if installed.
6. Close main battery switch (switch on).



### 11.4.3 Starting up the generator

**Deadly danger!** - The generator can be equipped with an Autostart function. This means that the generator is started by an external signal. In order to prevent an inadvertent start-up, the starter battery must be disconnected before work on the generator may commence.

**WARNING: Automatic start-up**



1. Switch on the xControl CP-G

The remote control panel is started by pressing the On/Off button. The On/Off button must be pressed until the Home page is displayed.

Fig. 11.4.3-1: Switch on the panel



2. Press the Start/Stop - Enter key

Fig. 11.4.3-2: Start the generator.



3. The xControl performs a self-test.

Fig. 11.4.3-3: Self-test

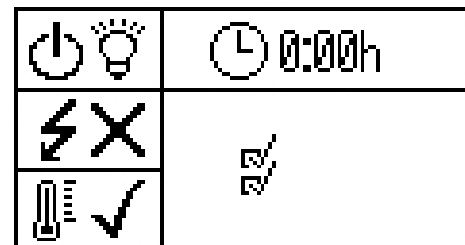

4. The xControl preheats the diesel engine.

Fig. 11.4.3-4: Preheating

After preheating, the generator is started by the xControl system.

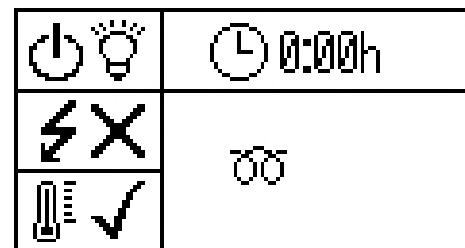

5. Starter on.

Fig. 11.4.3-5: Electric starter

In order to minimise current consumption, preheating is interrupted briefly when the starter is operated.



## 6. Starter and preheater

As soon as the high inrush current of the starter has dropped, preheating is switched on again.

Fig. 11.4.3-6: Preheating

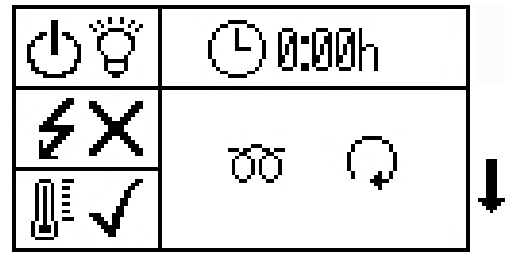

The engine idles for the first few seconds. Thereafter, the xControl increases the speed to the operating speed and indicates this in the display.

Fig. 11.4.3-7: Increase revolutions

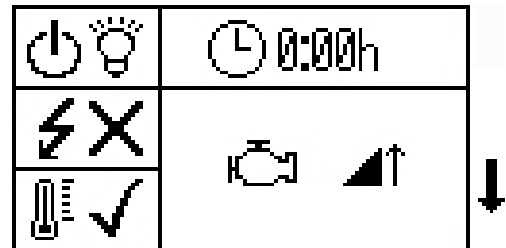

As soon as the AC voltage is within the limits (200-250V) (normal operating mode), the load can be connected.

Fig. 11.4.3-8: AC OK

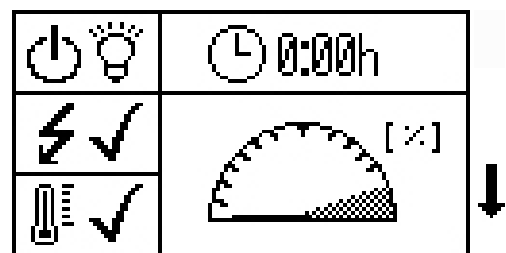

**Close the raw water intake valve in the event start-up problems (Panda Marine generators only)**

**ATTENTION:**



If multiple attempts to start up are required (e.g. to bleed the fuel lines), then the raw water intake valve must definitely be shut while the attempts are being made. The cooling water impeller turns during the starting process and feeds cooling water. As long as the engine has not started up, the exhaust gas pressure is insufficient to discharge the coolant water that has been introduced. This protracted start-up process would flood the exhaust system with water. This can damage/destroy the generator/engine.

*Re-open the raw water intake valve as soon as the generator has started.*

## 11.4.4 Stopping the generator

1. Switch off loads.
2. Recommendation: With turbo engines and under a load that exceeds 70 % of the rated output, allow the generator temperature to stabilise for at least 5 minutes with load switched off.

At higher ambient temperatures (greater than 25 °C) the generator should always run for at least 5 minutes without load before it is switched off, regardless of the load having been switched off.



3. Press "Start/Stop" button (switching off).

Fig. 11.4.4-1: Stopping



**NOTE:** Never switch off the main battery until the generator has stopped, shut the fuel valve if necessary!

**ATTENTION:**



## 11.5 The Menu

One can access the menu from the final overview page.

Fig. 11.5-1: Menu entry symbols

Switch on the CP-G and scroll down to "Enter Menu Page".

Press the Start/Stop - Enter key to enter the menu.



### 11.5.1 Main Menu

You can choose from the following sub-menus in the main menu:

Fig. 11.5.1-1: Main Menu

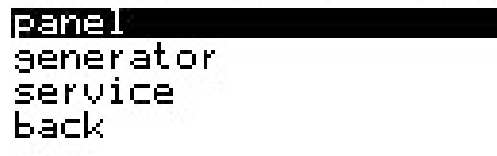

1. "Panel" sub-menu - The display of the of the panel can be adapted in the "Panel" sub-menu (e.g. brightness, language, etc.).
2. "Generator" sub-menu - All settings related to the generator can be made in the "Generator" sub-menu, e.g. bleeding the fuel pump etc.
3. The "Service" sub-menu is blocked and can only be accessed by trained personnel and Fischer Panda employees.
4. Back - back to the overview pages



## 11.5.2 Sub-menu: "Panel"

The following items can be selected in the Panel sub-menu:

1. Lighting
    - changes the brightness of the display in normal mode.
  2. Contrast
    - changes the contrast of the display.
  3. Standby Time
    - to set the time until the panel switches to standby mode.
  4. Standby Lighting
    - changes the brightness of the display in standby mode.
  5. Display Mode
    - changes the display mode of the overview pages.
  6. Language selection
    - changes the language of the panel
  7. Temperature Unit
    - to set the temperature unit to °C or °F
  8. Audible alarm
    - to activate the audible alarm in the event of a fault
  9. Flashing when faulty
    - to activate panel flashing in the event of a fault
  10. Panel heating
    - activates panel heating at temperatures  $<+10^{\circ}\text{C}$
  11. Reset to standard
- The "Panel" sub-menu
12. is reset to the factory settings
    - Switching from the "Panel" sub-menu to the Main Menu

Fig. 11.5.2-1: Sub-menu: Panel

```
brightness
contrast
standby-timeout
standby-brightness
way of illustration
choose language
temperature unit

acoustic alert
blink on error
panel-heater
opt. measured data
reset to standard
back
-----
```

### 11.5.2.1 Setting the illumination of the CP-G

The menu item is selected by using the "Step-up"/"Step-down" keys confirmed with the "Start/Stop - Enter" key. The respective menu item opens.



The value is changed by using the "Step-up"/"Step-down" keys and the setting is confirmed with the "Start/Stop - Enter" key.

"Cancel" or "Confirm" can be selected by using the "Step-up"/"Step-down" keys and then confirmed with the "Start/Stop - Enter" key.

Fig. 11.5.2.1-1: Sub-menu: Illumination

```
minimum value      0%  
brightness         89%  
maximum value     100%  
  
cancel  
confirm
```

### 11.5.2.2 Setting the contrast of the CP-G

The menu item is selected by using the "Step-up"/"Step-down" keys confirmed with the "Start/Stop - Enter" key. The respective menu item opens.

The value is changed by using the "Step-up"/"Step-down" keys and the setting is confirmed with the "Start/Stop - Enter" key.

"Cancel" or "Confirm" can be selected by using the "Step-up"/"Step-down" keys and then confirmed with the "Start/Stop - Enter" key.

Fig. 11.5.2.2-1: Sub-menu: Contrast

```
minimum value      0%  
contrast          24%  
maximum value     100%  
  
cancel  
confirm
```

### 11.5.2.3 Setting the standby time of the CP-G

The menu item is selected by using the "Step-up"/"Step-down" keys confirmed with the "Start/Stop - Enter" key. The respective menu item opens.

The value is changed by using the "Step-up"/"Step-down" keys and the setting is confirmed with the "Start/Stop - Enter" key.

"Cancel" or "Confirm" can be selected by using the "Step-up"/"Step-down" keys and then confirmed with the "Start/Stop - Enter" key.

Fig. 11.5.2.3-1: Sub-menu: Standby Time

```
minimum value      1min  
standby in        60min  
maximum value     60min  
  
cancel  
confirm
```

### 11.5.2.4 Setting the standby illumination of the CP-G

The menu item is selected by using the "Step-up"/"Step-down" keys confirmed with the "Start/Stop - Enter" key. The respective menu item opens.

The value is changed by using the "Step-up"/"Step-down" keys and the setting is confirmed with the "Start/Stop - Enter" key.

"Cancel" or "Confirm" can be selected by using the "Step-up"/"Step-down" keys and then confirmed with the "Start/Stop - Enter" key.

Fig. 11.5.2.4-1: Sub-menu: Standby Illumination

```
minimum value      0%  
stb. bright.      10%  
maximum value     100%  
  
cancel  
confirm
```

### 11.5.2.5 Setting the display mode of the CP-G overview page

The menu item is selected by using the "Step-up"/"Step-down" keys confirmed with the "Start/Stop - Enter" key. The



respective menu item opens.

"Symbolic View" or "Text View" can be selected by using the "Step-up"/"Step-down" keys and then confirmed with the "Start/Stop - Enter" key.

The "Back" item returns you to the "Panel" sub-menu.

"Cancel" or "Confirm" can be selected by using the "Step-up"/"Step-down" keys and then confirmed with the "Start/Stop - Enter" key.

Fig. 11.5.2.5-1: Sub-menu: Display Mode

```
-----  
symbolic view  
text-view  
back  
-----  
cancel  
confirm
```

### 11.5.2.6 Setting the language of the text pages of the CP-G

The menu item is selected by using the "Step-up"/"Step-down" keys confirmed with the "Start/Stop - Enter" key. The respective menu item opens.

Select the corresponding language by using the "Step-up"/"Step-down" keys and then confirm with the "Start/Stop - Enter" key.

"Cancel" or "Confirm" can be selected by using the "Step-up"/"Step-down" keys and then confirmed with the "Start/Stop - Enter" key.

Fig. 11.5.2.6-1: Sub-menu: Language Selection

```
Deutsch  
english  
chinese  
back  
-----  
cancel  
confirm
```

### 11.5.2.7 Setting the Temperature Unit

The menu item is selected by using the "Step-up"/"Step-down" keys confirmed with the "Start/Stop - Enter" key. The respective menu item opens.

"°C" for "degrees Celsius" or "°F" for "degrees Fahrenheit" can be selected by using the "Step-up"/"Step-down" keys and then confirmed with the "Start/Stop - Enter" key.

The "Back" item returns you to the Panel sub-menu.

"Cancel" or "Confirm" can be selected by using the "Step-up"/"Step-down" keys and then confirmed with the "Start/Stop - Enter" key.

Fig. 11.5.2.7-1: Sub-menu: Temperature Unit

```
-----  
°C  
°F  
back  
-----  
cancel  
confirm
```

### 11.5.2.8 Setting the Aural Alarm

The menu item is selected by using the "Step-up"/"Step-down" keys confirmed with the "Start/Stop - Enter" key. The respective menu item opens.



"Off" or "On" can be selected by using the "Step-up"/"Step-down" keys and then confirmed with the "Start/Stop - Enter" key.

The "Back" item returns you to the Panel sub-menu.

"Cancel" or "Confirm" can be selected by using the "Step-up"/"Step-down" keys and then confirmed with the "Start/Stop - Enter" key.

Fig. 11.5.2.8-1: Sub-menu: Aural Alarm

```
-----  
>off  
on  
back  
-----
```

```
cancel  
confirm
```

### 11.5.2.9 Setting the display to flash in the event of a fault

The menu item is selected by using the "Step-up"/"Step-down" keys confirmed with the "Start/Stop - Enter" key. The respective menu item opens.

"Off" or "Error" or "Warning and Error" can be selected by using the "Step-up"/"Step-down" keys and then confirmed with the "Start/Stop - Enter" key.

The "Back" item returns you to the Panel sub-menu.

"Cancel" or "Confirm" can be selected by using the "Step-up"/"Step-down" keys and then confirmed with the "Start/Stop - Enter" key.

Fig. 11.5.2.9-1: Sub-menu: Flashing when Faulty

```
-----  
>off  
Errors  
warnings & errors  
back  
-----
```

```
cancel  
confirm
```

### 11.5.2.10 Setting the Panel Heating

The menu item is selected by using the "Step-up"/"Step-down" keys confirmed with the "Start/Stop - Enter" key. The respective menu item opens.

"Off" or "On" can be selected by using the "Step-up"/"Step-down" keys and then confirmed with the "Start/Stop - Enter" key.

The "Back" item returns you to the Panel sub-menu.

"Cancel" or "Confirm" can be selected by using the "Step-up"/"Step-down" keys and then confirmed with the "Start/Stop - Enter" key.

Fig. 11.5.2.10-1: Sub-menu: Panel Heating

```
-----  
>off  
on  
back  
-----
```

```
cancel  
confirm
```

### 11.5.2.11 Setting the display of the optional measurement data

The menu item is selected by using the "Step-up"/"Step-down" keys confirmed with the "Start/Stop - Enter" key. The respective menu item opens.



The desired optional measurement data is changed by using the "Step-up"/"Step-down" keys and the setting is confirmed with the "Start/Stop - Enter" key.

The desired option is selected by using the "Step-up"/"Step-down" keys and the setting is confirmed with the "Start/Stop - Enter" key.

The "Back" item returns you to the Panel sub-menu.

"Cancel" or "Confirm" can be selected by using the "Step-up"/"Step-down" keys and then confirmed with the "Start/Stop - Enter" key.

Fig. 11.5.2.11-1: Sub-menu: Optional Measurement Data

```
-----  
extra phase-data  
AGT-data  
fuel-level  
3 phases  
oil-/air-pressure  
back
```

```
cancel  
confirm
```

### 11.5.2.12 Resetting all values of the Panel sub-menu to default values

The menu item is selected by using the "Step-up"/"Step-down" keys confirmed with the "Start/Stop - Enter" key. The respective menu item opens.

"Cancel" or "Confirm" can be selected by using the "Step-up"/"Step-down" keys and then confirmed with the "Start/Stop - Enter" key.

Fig. 11.5.2.12-1: Resetting all values

```
cancel  
confirm
```

### 11.5.2.13 Return to Main Menu

The menu item is selected by using the "Step-up"/"Step-down" keys confirmed with the "Start/Stop - Enter" key. The respective menu item opens.

## 11.5.3 Sub-menu: "Generator"

The following items can be selected in the Generator sub-menu:

1. Autostart  
*- configuring the Autostart function*
2. Optional DC Output  
*- setting the optional DC output*
3. Switch Outputs  
*- manual switching of the individual digital outputs*
4. Event Memory  
*- displaying the event memory*
5. Display System Devices  
*- displaying the detected system devices*
6. Reset to standard  
*- all parameters of the "Generator" sub-menu are reset to*

Fig. 11.5.3-1: Generator Sub-Menu

```
autostart  
opt. DC-output  
switch outputs  
event-log  
show system-devices  
reset to standard  
back
```



the factory settings

## 7. Back

- Switching from the "Generator" sub-menu to the Main Menu

### 11.5.3.1 Setting the Autostart of the CP-G

The menu item is selected by using the "Step-up"/"Step-down" keys confirmed with the "Start/Stop - Enter" key. The respective menu item opens.

A choice can be made between "Switch on/off" and "Number of start-up attempts" in in the "Autostart" sub-menu.

Fig. 11.5.3.1-1: Autostart

```

-----
turn on / off
amount of restarts
back
-----

```

#### Switching On / Off

"Off" for deactivated or "On" for activated can be selected by using the "Step-up"/"Step-down" keys and then confirmed with the "Start/Stop - Enter" key.

Fig. 11.5.3.1-2: Autostart

```

-----
>off
on
back
-----

```

"Cancel" or "Confirm" can be selected by using the "Step-up"/"Step-down" keys and then confirmed with the "Start/Stop - Enter" key.

```

-----
cancel
confirm
-----

```

#### Number of start-up attempts

The value is changed by using the "Step-up"/"Step-down" keys and the setting is confirmed with the "Start/Stop - Enter" key.

Fig. 11.5.3.1-3: Autostart

```

-----
minimum value           1
autorestarts            1
maximum value           5
-----
cancel
confirm
-----

```

"Cancel" or "Confirm" can be selected by using the "Step-up"/"Step-down" keys and then confirmed with the "Start/Stop - Enter" key.

For safety reasons, the number of start-up attempts is limited to one in the case of marine (PMS) generators.

**Deadly danger! - The generator can be equipped with an Autostart function. This means that the generator is started by an external signal. In order to prevent an inadvertent start-up, the starter battery must be disconnected before work on the generator may commence.**

**Warning! Automatic start-up**



The "Autostart" also remains active if the xControl CP-G is switched off and then on again.

If a fault should arise when the generator is started or is already operating, it is stopped and the Autostart is set to "off".

If the generator is operated by Autostart and is stopped manually, the Autostart is set to "off".

Once the system has been switched off and then on again, the Autostart is active once more.

The first overview page shows if the Autostart is active.

Fig. 11.5.3-4: Overview Page 1 with Autostart



### 11.5.3.2 Setting the optional DC output of the CP-G

The menu item is selected by using the "Step-up"/"Step-down" keys confirmed with the "Start/Stop - Enter" key. The respective menu item opens.

"Operating Mode" or "Follow-up Time" can be selected by using the "Step-up"/"Step-down" keys and then confirmed with the "Start/Stop - Enter" key.

The "Back" item returns you to the "Generator" sub-menu.

Select cancel or confirm by using the "Step-up"/"Step-down" keys and then confirm with the "Start/Stop - Enter" key.

#### Setting the "Operating Mode" for the opt. DC Output (DP) of the CP-G

An option can be selected by using the "Step-up"/"Step-down" keys and the setting is confirmed with the "Start/Stop - Enter" key.

"Cancel" or "Confirm" can be selected by using the "Step-up"/"Step-down" keys and then confirmed with the "Start/Stop - Enter" key.

#### Setting the follow-up time of the optional DP Output of the CP-G

The value is changed by using the "Step-up"/"Step-down" keys and the setting is confirmed with the "Start/Stop - Enter" key.

"Cancel" or "Confirm" can be selected by using the "Step-up"/"Step-down" keys and then confirmed with the "Start/Stop - Enter" key.

### 11.5.3.3 Switching the switching outputs of the CP-G

The menu item is selected by using the "Step-up"/"Step-down" keys confirmed with the "Start/Stop - Enter" key. The respective menu item opens.

Fig. 11.5.3.2-1: Sub-menu: Optional DC Output

```
-----
operating mode
follow-up time
back
```

Fig. 11.5.3.2-2: Sub-menu: Operating Mode

```
off
always on
gen run
gen run & overrun
>depending on temp.
back
-----
```

```
cancel
confirm
```

Fig. 11.5.3.2-3: Sub-menu: Follow-up Time

```
minimum value    0.1s
time             0.0s
maximum value    60.0s
```

```
cancel
confirm
```



Select the "Fuel Pump" or "Opt. DC Outputs" by using the "Step-up"/"Step-down" keys and then confirm with the "Start/Stop - Enter" key.

The "Back" item returns you to the "Generator" sub-menu.

The value of the output can be set to "0" for deactivated or "1" for activated by using the "Step-up"/"Step-down" keys. Confirm with the "Start/Stop - Enter" key.

Fig. 11.5.3.3-1: Sub-menu: Switching Outputs

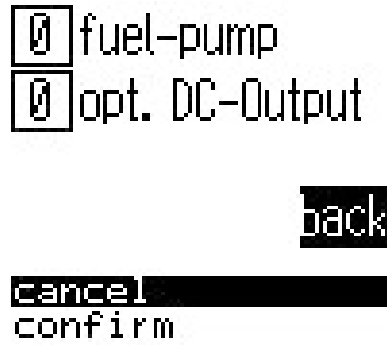

### 11.5.3.4 Reading out the Event Log of the CP-G

The menu item is selected by using the "Step-up"/"Step-down" keys and confirmed with the "Start/Stop - Enter" key. The respective menu item opens.

See "Table of Faults" on page 168. See "Description of the symbols" on page 170.

Fig. 11.5.3.4-1: Event Memory



One can scroll through the event memory by using the "Step-up"/"Step-down" keys and then return to the Generator menu with the "Start/Stop - Enter" key.

### 11.5.3.5 Resetting all values of the Generator sub-menu to the default values

The menu item is selected by using the "Step-up"/"Step-down" keys confirmed with the "Start/Stop - Enter" key. The respective menu item opens.

"Cancel" or "Confirm" can be selected by using the "Step-up"/"Step-down" keys and then confirmed with the "Start/Stop - Enter" key.

Fig. 11.5.3.5-1: Resetting all values



### 11.5.3.6 Returning the Main Menu

The menu item is selected by using the "Step-up"/"Step-down" keys confirmed with the "Start/Stop - Enter" key. The respective menu item opens.

## 11.5.4 Resetting the panel language to the default (English)

1. Press and hold the "Step down" key with the panel switched off.
2. Switch on the panel and hold down the "Step down" key until the first overview screen is displayed.
3. The panel language has now been reset. All other settings are retained.

### 11.5.4.1 How to set the panel language after a reset.

1. Switching on the xControl Panel CP-G
2. Wait until the first overview screen appears.
3. Scroll to the last overview screen.
4. Press the "Start/Stop - Enter" key to access the menu.
5. Scroll down to the "Panel" menu item.
6. Press the "Start/Stop - Enter" key to access the "Panel" sub-menu.
7. Scroll down to the "Choose language" menu item.
8. Press the Start/Stop - Enter key to access the "Language Selection" sub-menu.
9. Scroll to the desired language and confirm with the "Start/Stop - Enter" key.
10. Scroll down to the "Confirm" menu item and press the "Start/Stop - Enter" key.

The menu text is now set to the selected language.

## 11.6 Faults

---

### 11.6.1 Symbols and messages on the display

---

#### 11.6.1.1 Example of message - "Sensor defective"

As soon as a defective sensor is detected, the xControl reports this on the display.



Fig. 11.6.1.1-1: Sensor defective

		26°C	✓
		---°C	
		25°C	✓

#### 11.6.1.2 Example of message - "Sensor/Cable break"

If the sensor has failed or the cable is broken, the following report is displayed:



Fig. 11.6.1.2-1: Sensor/Cable break

		24°C	✓
		---°C	X
		23°C	✓

### 11.6.2 Error code

---

An error code is displayed if a parameter lies beyond its operating limits.

See "Table of Faults" on page 168. See "Description of the symbols" on page 170.

Example: Error No. 7 - Oil pressure too low -Fault led to emergency shutdown



Fig. 11.6.2.0-1: Sub-menu: "Event Log"

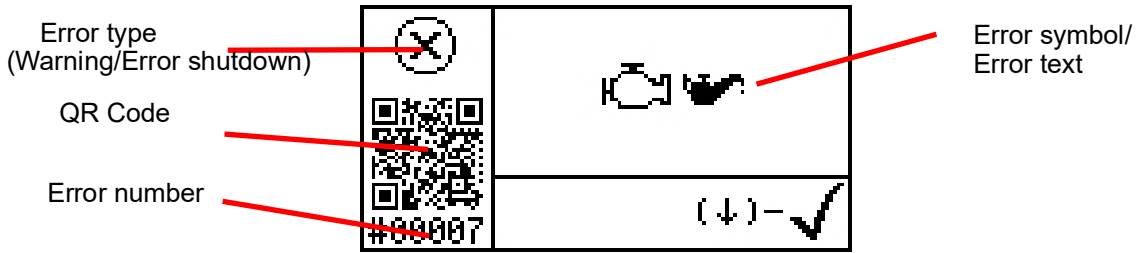

### 11.6.2.1 Table of Faults

See also the "Faults" chapter in the manual of the generator.

Fig. 11.6-1: Table of faults

No.	Description	Cause	Explanation	Warning	Gen.Stop	Info
1	AC Voltage	Voltage too low		yes	yes	n.a.
2	AC Frequency	Frequency too low		yes	yes	n.a.
5	Emergency	Emergency button pushed	"Emergency" contact open	n.a.	yes	n.a.
7	Oil pressure	Oil pressure too low	Failure oil pressure switch	n.a.	yes	n.a.
13	Starter power	Starter failure	Short circuit starter defect	yes	n.a.	n.a.
14	Glow circuit	Glow circuit failure	Short circuit defect	yes	n.a.	n.a.
16	Fuel supply	Failure fuel supply	Short circuit defect	yes	n.a.	n.a.
17	Stop solenoid - Hold	Failure stop solenoid hold coil	Short circuit	yes	n.a.	n.a.
18	Stop solenoid - Pull	Failure stop solenoid pull coil	Short circuit	yes	n.a.	n.a.
19	Optional DC out	Failure optional DC out	Short circuit	yes	n.a.	n.a.
20	Current sensor	No voltage on supply current sensor	Short circuit defect		yes	
25	Battery voltage	Battery voltage too low		yes	yes	
26	RPM failure	RPM out of range	Failure fuel supply Fuel empty	n.a.	yes	
29	Power out relay	Failure power out relay	Short circuit	n.a.	n.a.	
30	AC Voltage L2	Voltage too low L2		yes	yes	
31	AC Frequency L2	Frequency too low L2		yes	yes	
34	AC Voltage L3	Voltage too low L3		yes	yes	
35	AC Frequency L3	Frequency too low L3		yes	yes	
63	Fuel level	Fuel level to low		yes	no	
65	AC Voltage	Voltage too high		yes	yes	
66	AC Frequency	Frequency to high		yes	yes	
67	AC Current	Current too high		yes	n.a.	
68	AC Power	Load too high		yes	n.a.	
70	Servo Power	Power too high	Mechanically blocked. Power consumption too high, short circuit	yes	yes	
72	Temperature Cylinder head	Temp. value too high		yes	yes	
73	Temperature Winding	Temp. value too high		yes	yes	
74	Temperature Exhaust	Temp. value too high		yes	yes	
75	Temperature Electronics	Temp. value too high		yes	n.a.	
77	Starter power	Starter failure	Short circuit starter defect	yes	n.a.	
78	Glow circuit	Glow circuit failure	Short circuit defect	yes	n.a.	
80	Fuel supply	Failure fuel supply	Short circuit defect	yes	n.a.	
81	Stop solenoid - Hold	Failure stop solenoid hold coil	Short circuit	yes	n.a.	



No.	Description	Cause	Explanation	Warning	Gen.Stop	Info
82	Stop solenoid - Pull	Failure stop solenoid pull coil	Short circuit	yes	n.a.	
83	Optional DC out	Failure optional DC out	Short circuit	yes	n.a.	
84	Power Supply	Current Sensor Current too high	Short circuit defect	yes	yes	
85	Boost Relay	Failure Boost relay	short circuit or too many modules	yes	yes	
86	Bus Power	Bus Power Consumption high	Short circuit	yes	no	
89	Battery voltage	Battery voltage too high		yes	yes	
93	Power out relay	Failure power out relay	Short circuit or defect	yes	yes	
94	AC Voltage L2	Voltage too high L2		yes	yes	
95	AC Frequency L2	Frequency too high L2		yes	yes	
96	AC Current L2	Current too high L2		yes	n.a.	
97	AC Power L2	Power too high L2		yes	n.a.	
98	AC Voltage L3	Voltage too high L3		yes	yes	
99	AC Frequency L3	Frequency too high L3		yes	yes	
100	AC Current L3	Current too high L3		yes	n.a.	
101	AC Power L3	Power too high L3		yes	n.a.	
126	Temperature Fuel	Fuel Temperature too high		yes	n.a.	
130	No Panel found	Wrong patch cable/wrong contact	check cable/harness	n.a.	yes	n.a.
131	Communication FP BUS	Communication failure	lost communication with Panel	n.a.	yes	
132	Service interval	Service due		yes	n.a.	
133	BUS Module lost (3ph-measurement)			yes	n.a.	
134	BUS Module lost (DC-measurement)			n.a.	yes	
135	Sync failure	generators cannot be synced	second generator cannot be switched to the running generator		yes	
136	Communication motor controller	No data from motor controller	Short circuit defect		yes	
137	Air filter	Error Air filter	Bad air filter		yes	
139	Sync module	No data from sync module	Short circuit defect		yes	
140	load balancing	Generator takes less load	Generator produces insufficient power		yes	
141	Configuration sync module	Sync module available but not selected	Crippled mode only		no	
246	Service done	user	Service interval reset	n.a.	n.a.	yes
251	Admin Param changed	user	Parameter changed at Admin level	n.a.	n.a.	yes
255	Reserved			n.a.	n.a.	yes



## 11.6.2.2 Description of the symbols

Fig. 11.6-1: Description of the symbols

Symbol	Description		Symbol	Description	
	WARNING			Current	Generator output
	Error shutdown			Frequency	Generator output
	Faults	No contact		Voltage	Generator output
	Broken	Short circuit		(%)/Load	
	OK			Generator runs	
	AC Voltage			Generator off	
	Run-up phase/Override	Generator start-up		Temperature	
	Standby			Engine	
	Automatic start-up.			Exhaust system	
	Starter battery			Winding	
	Operating hours			Preheating	
	Oil pressure			Speed/RPM	
	Self test			Tank gauge %	
	Apparent power			Starter turns	

Example:

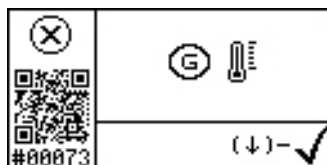

Error73: Error shutdown due to winding temperature

## 11.7 Accessories:

---

**FP Bus Cable (15 m): 34.02.02.131H**

*Fig. 11.7-1: FP Bus Cable (15 m): 34.02.02.131H*



**Terminating resistor:34.02.02.133H**

*Fig. 11.7-2: Terminating resistor:34.02.02.133H*



**Adapter Frame: 31.03.20.263H**

*Fig. 11.7-3: Adapter Frame: 31.03.20.263H*

**xContol CP-G in a Generator Control (P6+) section**

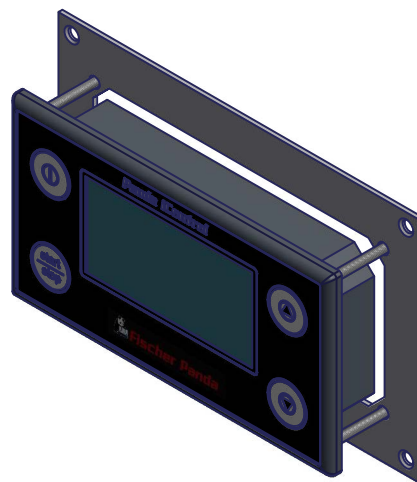



## 11.7.1 Dimensional drawing

Fig. 11.7.1-1: CP-G

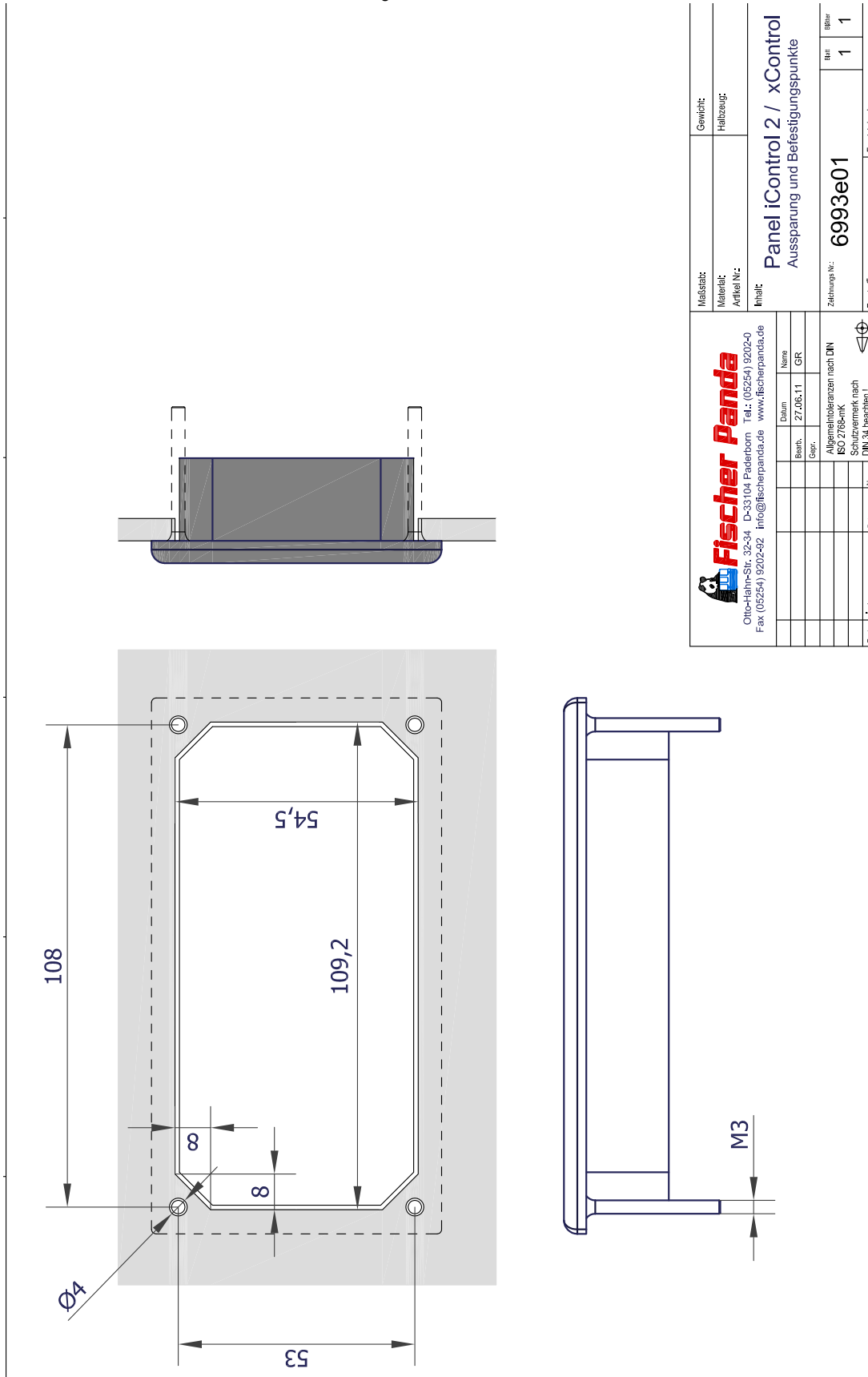

		<b>Maßstab:</b> <b>Material:</b> <b>Artikel-Nr.:</b>	<b>Gewicht:</b> <b>Halbzeug:</b>
Otto-Hahn-Str. 32-34 D-33104 Paderborn Tel.: (05254) 9202-0 Fax (05254) 9202-92 info@fischerpanda.de www.fischerpanda.de		<b>Inhalt:</b> <b>Panel iControl 2 / xControl</b> <b>Ausstattung und Befestigungspunkte</b>	
Datum: 27.06.11 Name: GR	Bearb.: Gepr.:	Zeichnungs-Nr.: <b>6993e01</b>	Blatt: <b>1</b>
Allgemeine Toleranzen nach DIN ISO 2768-mK Schutzmerk nach DIN 913 beachten!		Ersatz durch:	Blatt: <b>1</b>
Zust.	Anmerkungen		